



Add-On Products

Resource Central

Administrator Guide

For RC 4.3

Document Revision 19

Add-On Products
Roms Hule 8 – 7100 Vejle – Denmark
Phone: +45 7944 7000 Fax: +45 7944 7001

Mail: info@add-on.com
Internet: www.add-on.com



No parts of this publication may be reproduced in any form or by any means or used to make any derivative such as translation, transformation, or adaptation without the permission from Add-On Products.

Table of contents

Table of contents	2
Terminology	4
CHAPTER 1.	5
Introduction	5
Resource Central Overview	5
Synchronize Service.....	8
CHAPTER 2.	9
Resource Central COM Add-in	9
Introduction.....	9
ResourceFinder in COM Add-in	9
My Meetings in COM Add-in	47
Ordering additional services.....	57
CHAPTER 3.	82
Resource Central Outlook Add-in	82
ResourceFinder in Outlook Add-in	82
My Meetings in Outlook Add-in	93
CHAPTER 4.	95
Resource Central System Admin Interface	95
Daily Tasks	96
Reports	152
Designer	191
Location	261
Security.....	279
System.....	294
CHAPTER 5.	321
Time Zone Settings.....	321
Application Time Settings.....	321
Time Zone Settings in ResourceFinder.....	323
Time Zone Settings in My Meetings	323
Time Zone Settings in Resource Central Admin Interface.....	324
Time Zone Settings in Order Flow.....	325
Time Zone Settings in Resource Central Manager Interface.....	331
CHAPTER 6.	332
Digital Signage Integration	332
CHAPTER 7.	334
Appendix.....	334
Virtual Resource Filtration over ResourceFinder	334
Auto Arrange Functionality	334
Reminder Email Functionality.....	335
Item Quota Functionality	337
Addition of Account Number text box to Order Form	341
Print order with signature line.....	344
Location handling when booking resources	345
My Meetings Stand Alone Page	346
Tree structure	347
Context menu	348
Tree Node functions	348
Access Control	349
Workflow.....	350
Guest house booking	352
Trouble shooting.....	353



Steps for Administrator to set up Roles, create Properties and Design Shared Order Form for Shared Order 1.0 feature	354
How to change language and password in RC backend	354
Introduction of new System account and SysAdmin role	355
Password recovery	355
Text customization in Resource Central	357
Resource Booking Policies and Permissions	360
Outlook on the web Support	365
Dependency function	365
Tax receipt feature	374
Pooled Resources - Configuration in Exchange	379
Set up external percentage using Resource Data Synch	380
External Users	382



Terminology

Term	Definition
Resource	Venue of an appointment. It can be a meeting room, a hotel, or any place in which an event can take place.
Reservation	Booking of an appointment with or without services.
Order	Booking of extra services within a reservation.
AD (Active Directory)	Service that provides the means to manage the identities and relationships that make up network environments.
Microsoft Exchange Server	The messaging platform that provides e-mail, scheduling, online forms, and the tools for custom collaboration and messaging-service applications.
Internet Information Services (IIS)	A Web server with integrated, reliable, scalable, secure, and manageable capabilities available over an intranet, the Internet, or an extranet, and is a tool for creating a strong communications platform of dynamic network applications.
Web application	A distributed application based around the Web, created with ASP.NET and hosted on Microsoft IIS.
Resource Central	It will be referred to in the document as RC .
RealTime Service	A mediator between Exchange Server and Resource Central. RTS directly works with Exchange Server and sends all data changes from Exchange Server to RC Database.
RC Processor	This is a Windows service which listens the event changes from SQL Server Queue and builds email content follow RC Business.
SQL Service Broker	Service Broker helps to build asynchronous, loosely coupled applications in which independent components work together to accomplish a task. These application components exchange messages that contain the information that is required to complete the task.

CHAPTER 1. Introduction

Resource Central Overview

Resource Central is one of the products of Add-On Products for resource management, partnering with Microsoft Outlook and the Exchange Server, which are bridged by RTS (refer to **RealTime Service User Guide** for more details). This product helps organizations to define, manage and maintain their resources even on distinct geographical locations. It also provides an integrated solution for authorized users to arrange meetings and events along with extra service orders through a customizable and user-friendly interface and then track the status of orders.

These are major interface components in this product:

- Resource Central Add-in interface for organizers.
- Resource Central Manager interface for system managers.

Apart from these, the product includes a Windows Service called Signage which facilitates the integration of Resource Central with external systems.

The following diagram describes the overall interaction of Resource Central with other stakeholders.

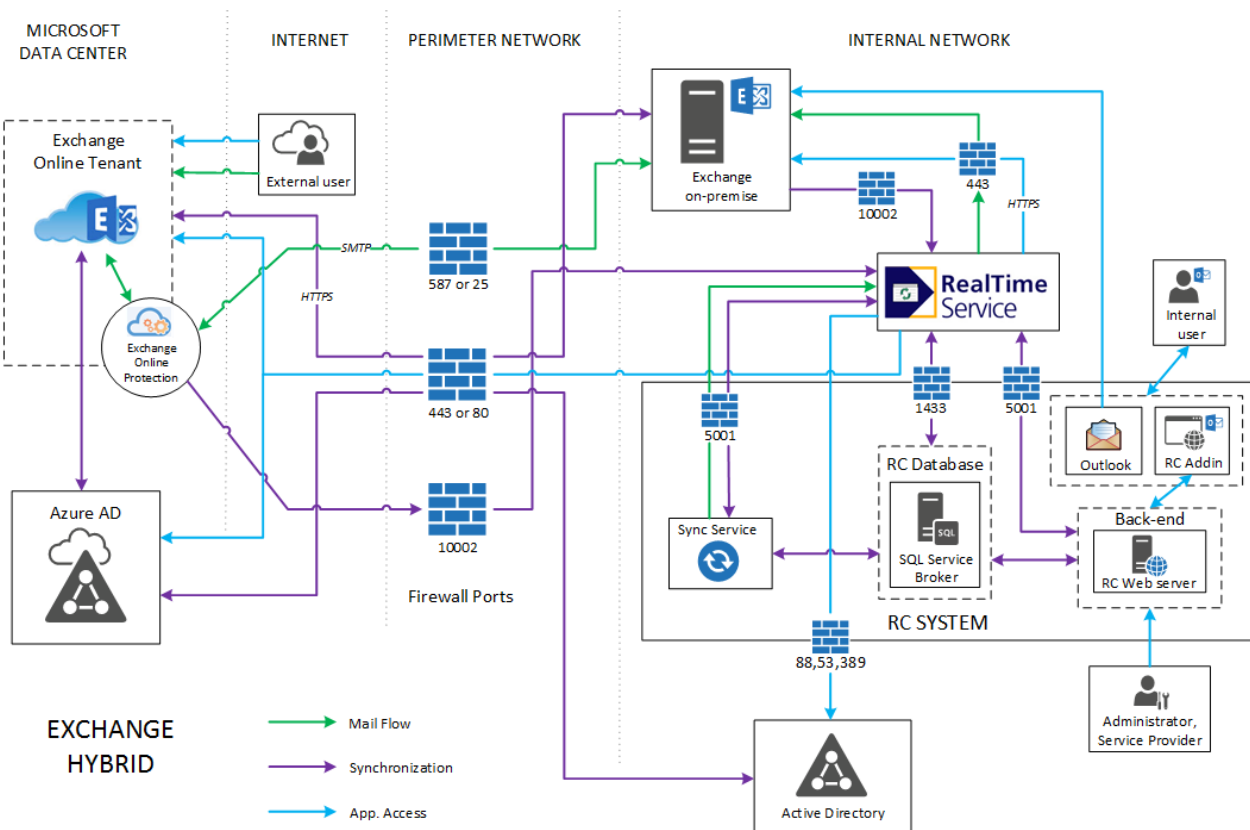

Figure 1. RC Interaction diagram (Exchange Hybrid)

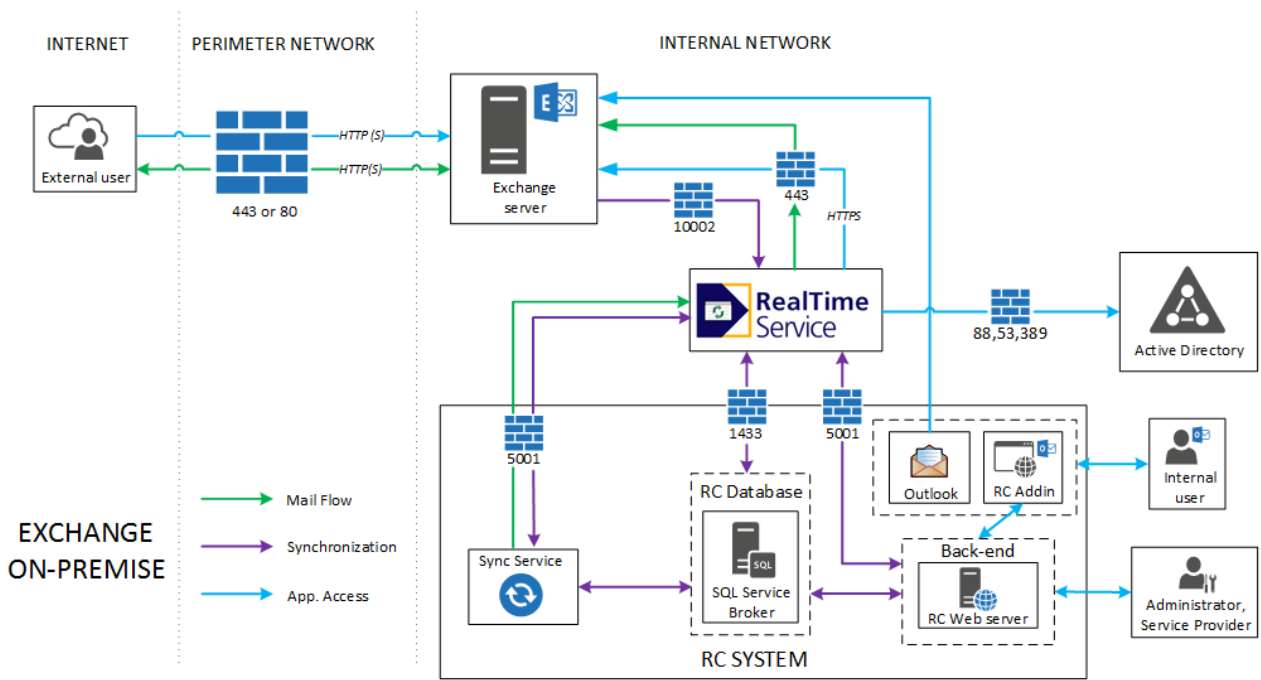

Figure 2. RC Diagram (Exchange On-Premise)

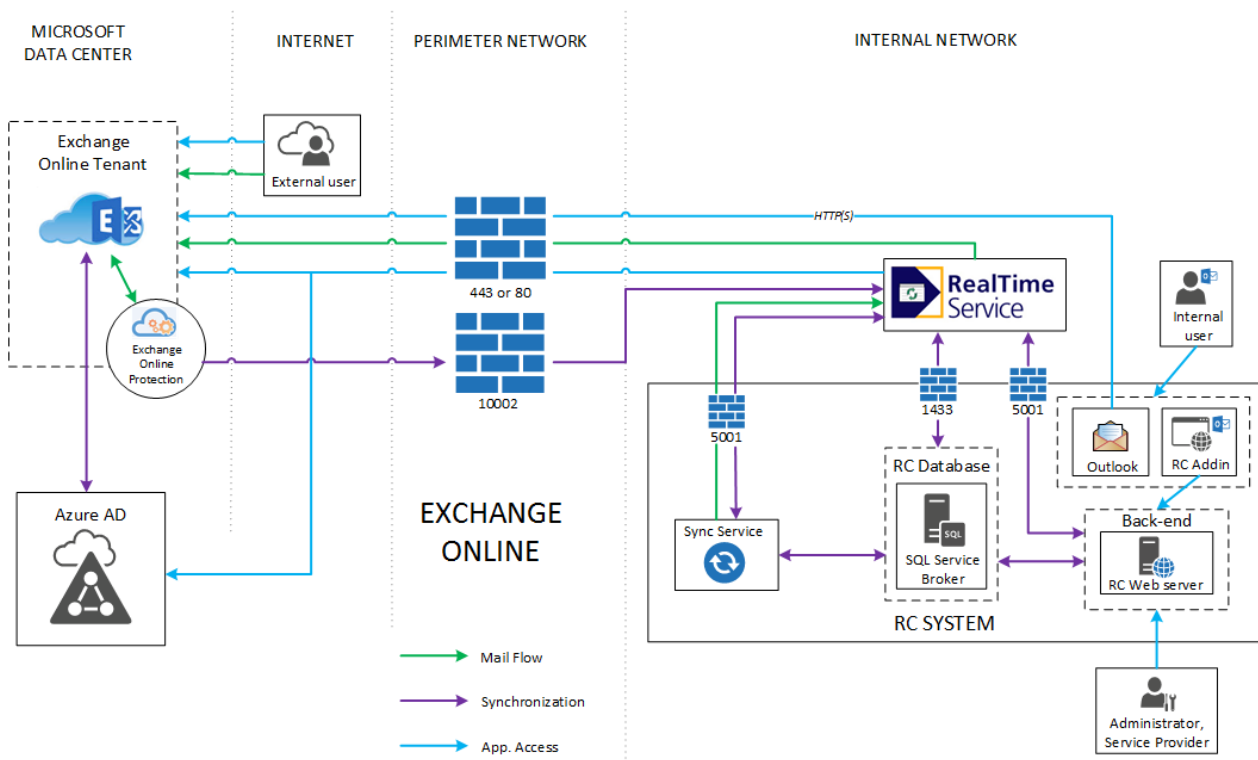

Figure 3. RC Diagram (Exchange Online)

1- Organizers communicate with RTS and perform following activities:

- Make reservations.
- Order additional services and specify details related to reservations.

- Track status of their reservations.
- 2- Service Providers receive emails from Resource Central and perform following activities:
 - Receive and acknowledge the information about the Resource, Items they need to arrange.
 - Update status of arrangements and communicate with Organizers through Resource Central.
 - 3- Admin users login to the Resource Central Admin interface, perform administration tasks according to their access permissions. Their tasks may include, but are not limited to the following:
 - Track activities of Organizers or Service Providers.
 - Generate reports and analyze reports generated by Resource Central.
 - Define and manage the Resources, Item, Assignments, Locations, and other data entities used in the system.
 - Manage system security.
 - 4- System user logs into the system and performs following tasks:
 - Manages the technical configurations/customizations of system e.g., Parameters, Licensing etc.
 - Tracks the mail routed through Resource Central and takes appropriate actions if needed.
 - Performs database level actions e.g., Data export, Troubleshooting etc.
 - 5- Signage is a batch program, which exports reservation related data from Resource Central Database to XML file. This facilitates the integration of Resource Central with external systems.

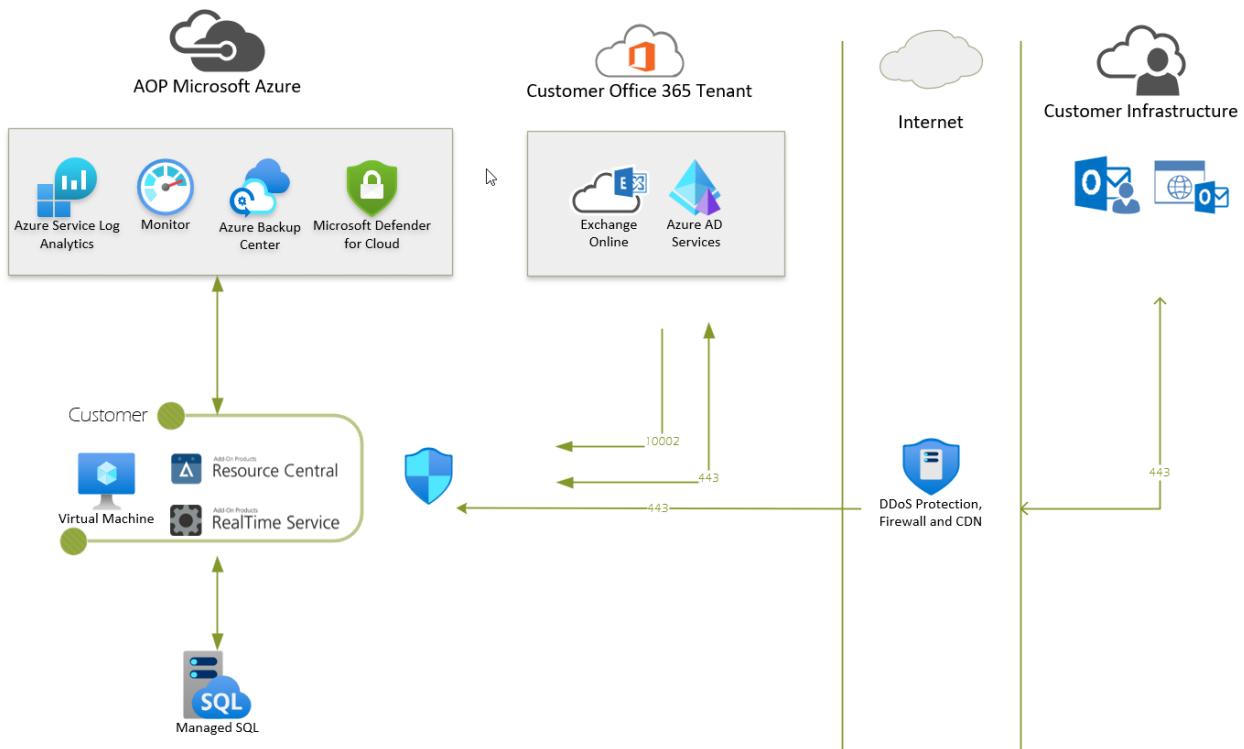

Figure 4. RC Diagram (Azure SaaS)

Resource Central SaaS infrastructure provides customers with an application server and a database stored on a managed SQL server. The application server helps with processing their software applications, while the managed SQL server provides a secure and reliable storage solution for their data.

Users can access this SaaS infrastructure through their on-premises network, which is connected to Resource Central servers via a secure connection. In addition, the infrastructure allows seamless integration with Office 365, which lets customers to access their data and applications from anywhere, at any time.



Overall, Resource Central SaaS infrastructure provides a comprehensive and reliable solution for users looking to efficiently manage their software applications and data storage needs.

Synchronize Service

Synchronize Service is a part of Resource Central Components which is responsible for communicating with Resource Central Database in tracking and synchronizing data changes of RC Database. Synchronize Service includes the following components:

- **SQL Service Broker:** Service Broker helps build synchronous, loosely coupled applications in which independent components work together to accomplish a task. These application components exchange messages containing the information required to complete the task. The data is sent to Service Broker from RC database as conversation and stored in SQL Server Queue internally.
- **RC Processor:** This is a Windows service which listens to event changes from SQL Server Queue and builds email content based on RC Business following the process:
 - RC processor listens to the data changed in the SQL Server Queue and receives these contents through XML format, then parses to Reservation object of RC.
 - RC Processor listens to event and receives the change information, then builds the email content according to the RC Business.
 - Send the email information to the EmailQueues table.

CHAPTER 2. Resource Central COM Add-in

Introduction

Resource Central COM Add-in provides organizers with the function to communicate with RTS and perform following activities:

1. Make new reservations.
2. Order additional services and specify details related to reservations.
3. Track status of their reservations.

The components of Resource Central COM Add-in are:

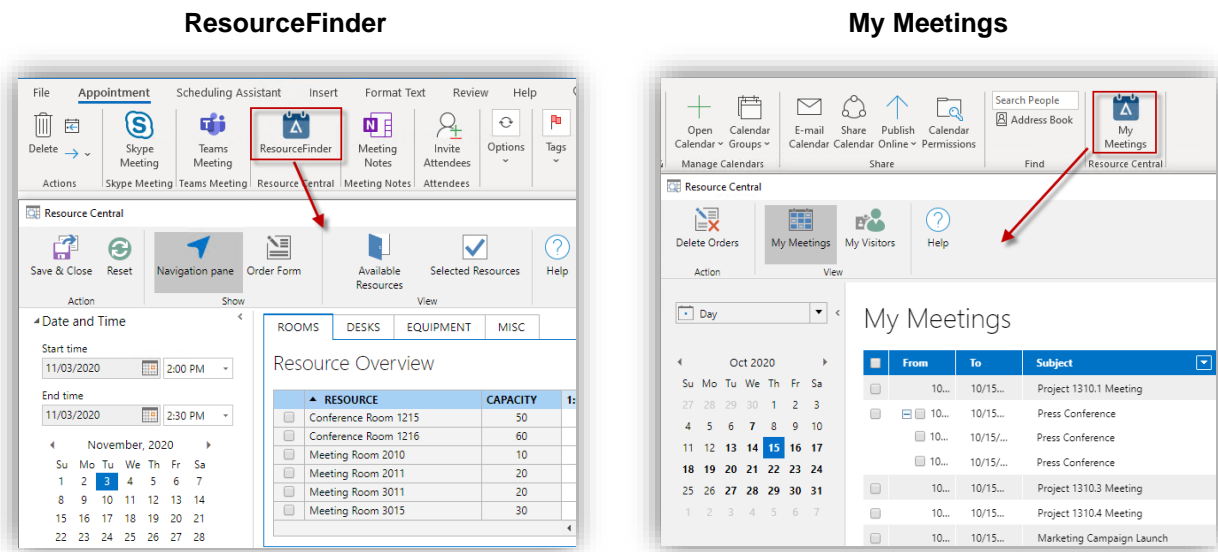

ResourceFinder in COM Add-in

ResourceFinder Interface

Toolbar Buttons

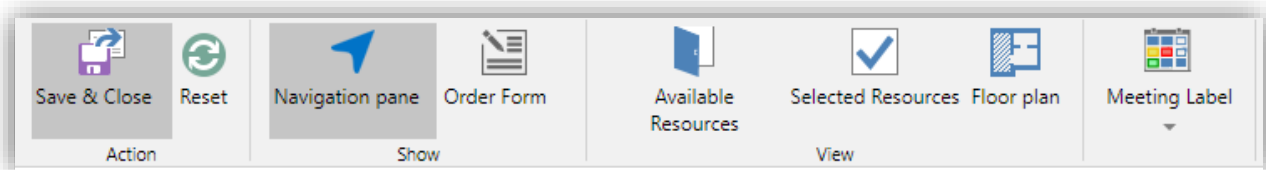











Figure 5. ResourceFinder Toolbar

The table below contains all buttons on the toolbar of ResourceFinder:

Buttons	Descriptions
 Save & Close	Saves your booking and returns to Outlook to complete your meeting request. Selected meeting time and selected resource(s) details are populated in MS Outlook appointment / meeting window.



 Reset	Removes all the rooms you have chosen and returns to the original state when you open ResourceFinder.
 Navigation pane	Go to Navigation pane
 Order Form	Open order form
 Attendees	Add attendees to the meeting.
 Available Resources	Click this button to filter all available resources at the selected timeslot.
 Selected Resources	Display all the selected resources.
 Floorplan	Display the location navigation tree above the Resource Overview, so that the organizer can navigate to the location level needed.
 Meeting Label	Select meeting label to be displayed in ResourceFinder

Settings

Language Setting

You can make configurations for Language to be used in ResourceFinder by clicking on the [**Settings**] button at the upper right corner of the interface. The following window shows up:

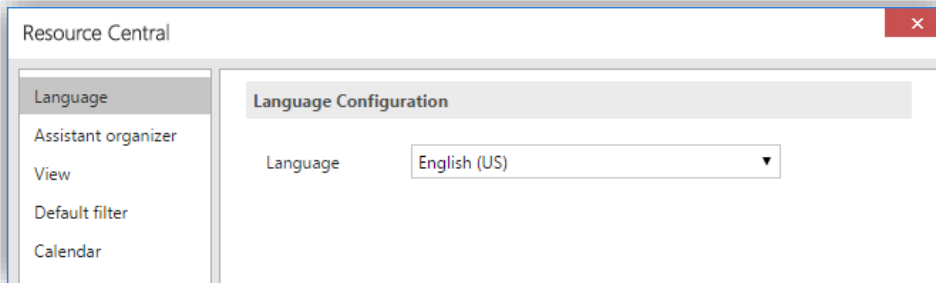

Figure 6. Settings – Language

Click [**OK**] to finish.

Assistant Organizer

In order to enable other organizers like secretaries or Personal assistants to book meetings and place orders in RC on behalf of other organizers, Resource Central provides an additional feature, namely “**Assistant Organizer**”.

The feature allows the organizer to assign all related work to the assistant as the notifications can be directed directly to the assistant who will correspond with the different service providers on the different service orders.

The assistant with access to the organizer’s calendar can also schedule the meeting directly in the organizer’s calendar and assign all notifications to the assistant.

This function is controlled by the parameter **ResourceFinder.AssistantOrganizer**. For more details about this parameter, please refer to **RC Parameter Guide**.

Enabling the feature in ResourceFinder

When this function is enabled by the parameter, the icon Assistant is still not available in the **ResourceFinder** → **Order Form**. It needs to be activated in the ResourceFinder settings/**Assistant organizer**:

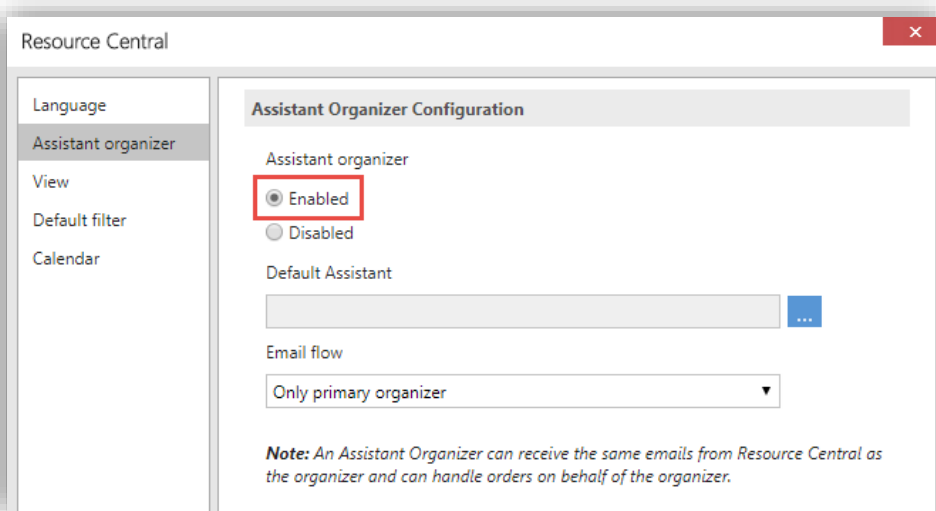

Figure 7. RF Settings – Assistant Organizer

Under Default Assistant, you can set up an assistant organizer that will be used as standard on all your orders. E.g., if all your meetings are always handled by the same assistant.

Click on the [...] button to select default Assistant.

You can also set up a default email flow (who will receive notification emails) by selecting from the drop-down list:

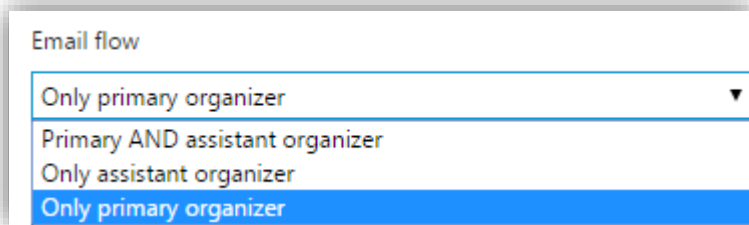
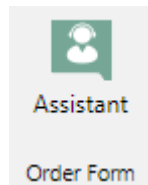

Figure 8. Email flow setup

After clicking [OK], the icon **Assistant** is available in **ResourceFinder** → **Order Form**. But it is only applied to the booking if you click on it

Disabled Assistant



Enabled Assistant

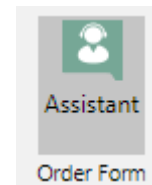

Enabling the function will make the assistant organizer available in the **ResourceFinder** → **Order Form**: there will be a section in the order form named “**Meeting Organizer**” on top when you make a booking:

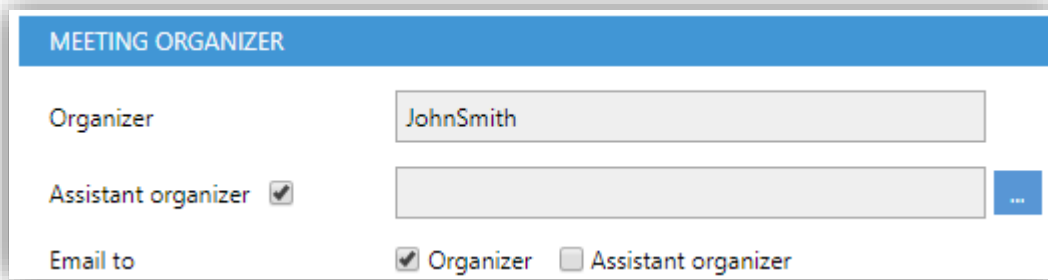

Figure 9. Order Form – Meeting Organizer

The options (assistant and email flow) established previously in **ResourceFinder settings** will be displayed here. You can make changes according to any need of the particular meeting or disable it if it is a meeting, where you do not need an assistant organizer.

The function is also available in My Meetings where the organizer can see who the assistant is at different meetings and the assistant can see the meetings of different organizers that the assistant supports.

This is what the primary organizer (in this example, it is John Smith) sees in My Meetings:

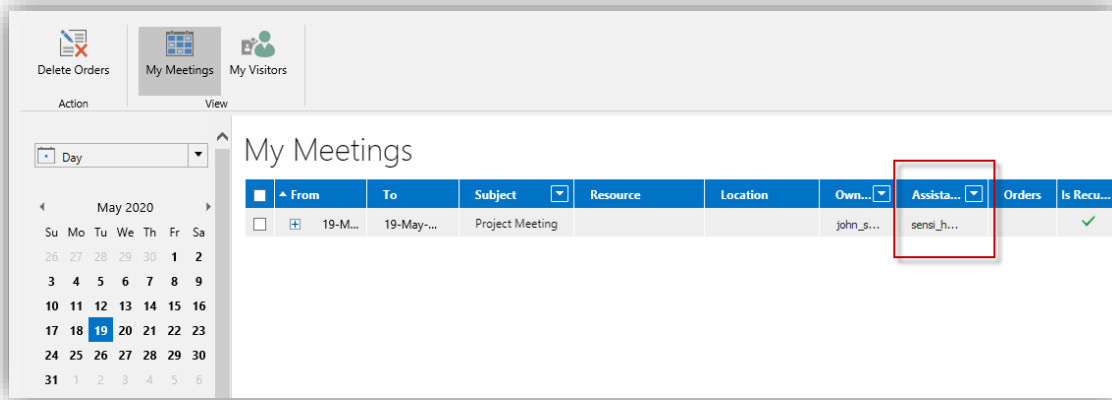

Figure 10. My Meetings opened by Primary Organizer

This is what the assistant organizer (in this example, it is Sensi Haukner) sees in My Meetings:

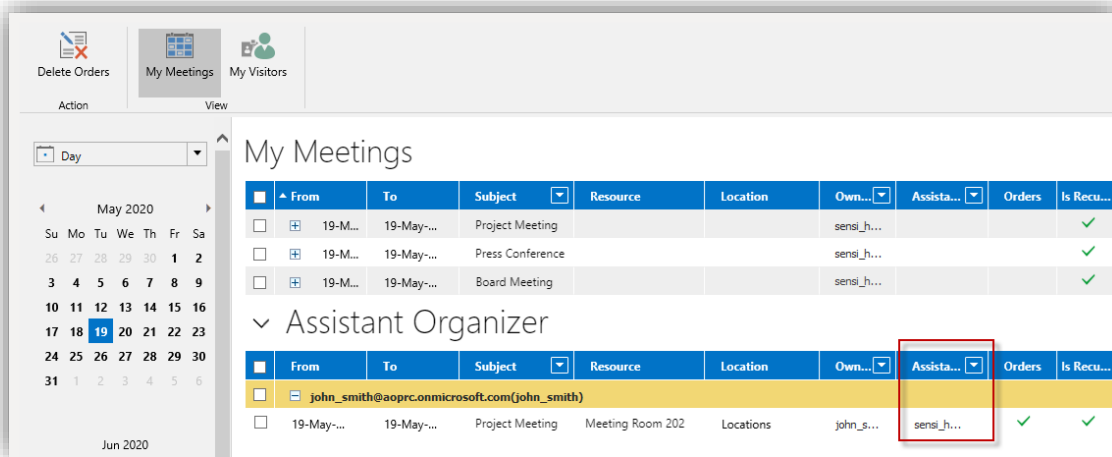

Figure 11. My Meetings opened by Assistant Organizer

In ResourceFinder, the assistant organizer will show on other reservations as well. The information is displayed as in the figure below:

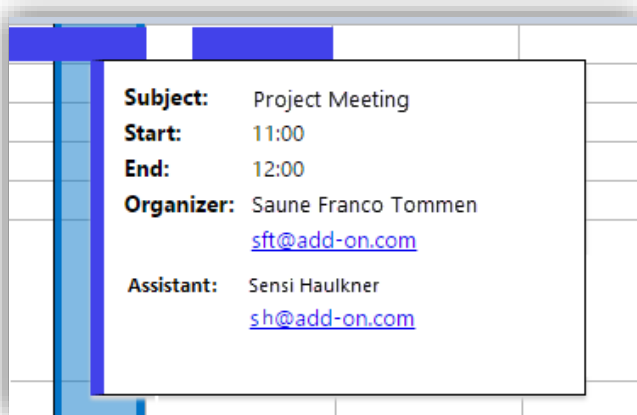

Figure 12. Resource Overview – Booking details

You can also see the Assistant Organizer in **Task** details:

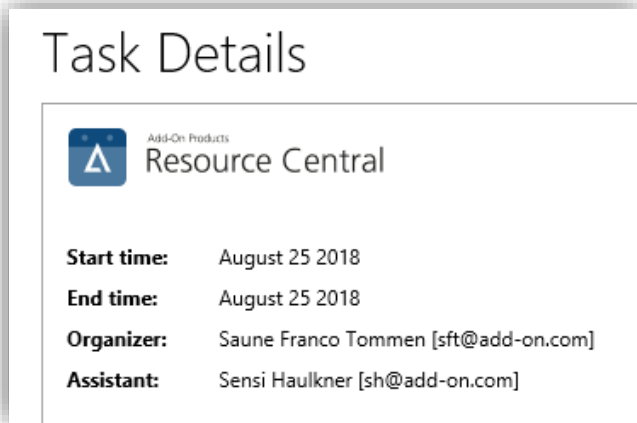

Figure 13. Task details

View

You can choose to display the following options by default on your ResourceFinder interface:

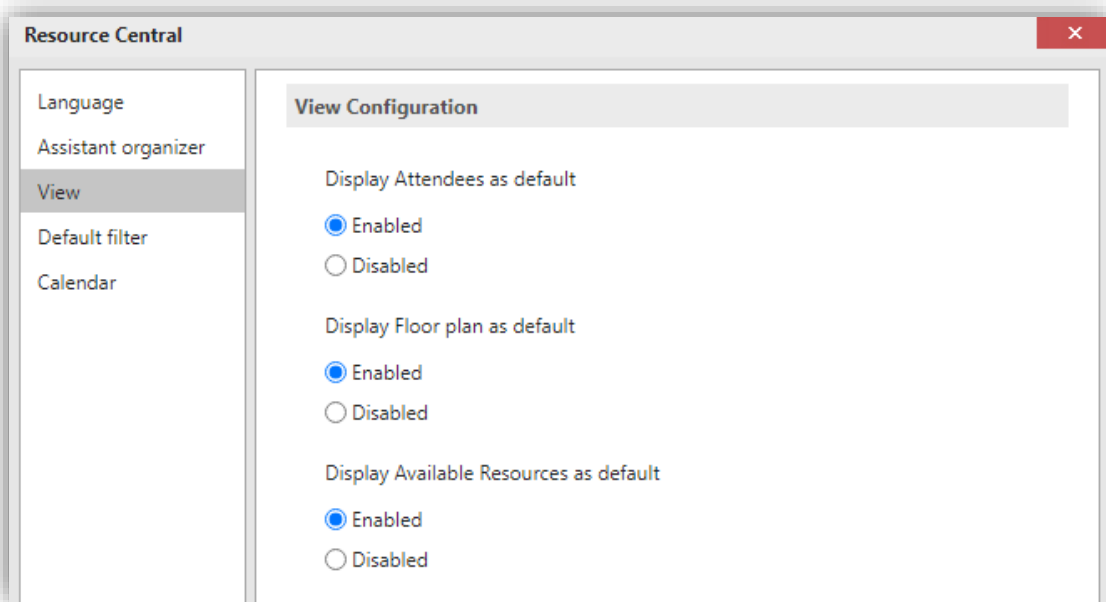
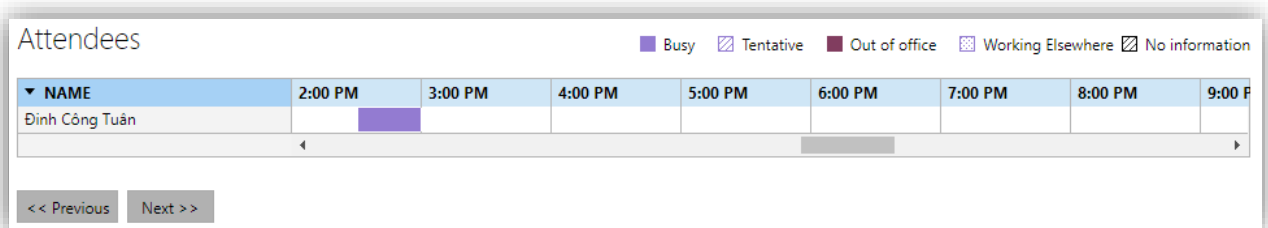
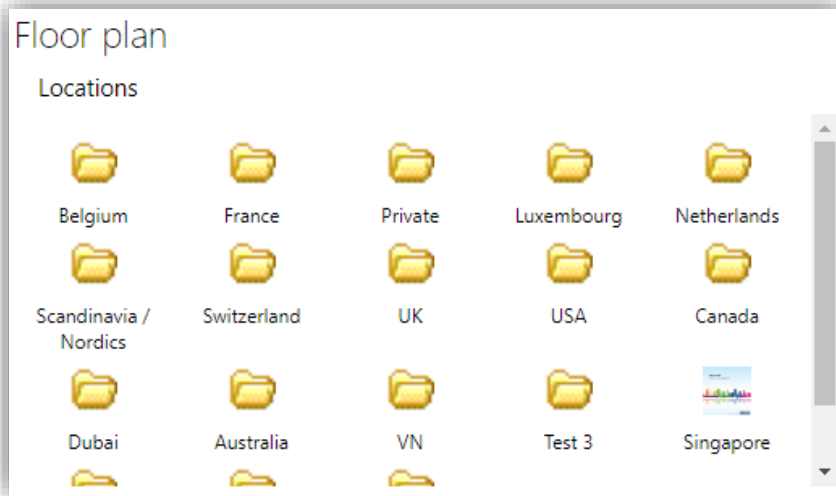

Figure 14. RF Settings – View

- **Display Attendees as default:** enable this option to display the ‘Attendees’ section



- **Display Floor plan as default:** enable this option to display the 'Floor plan' section



- **Display Available Resources as default:** enable this option to make the 'Resource Overview' section to show available resources only by default

The screenshot shows a window titled "Resource Overview" containing a table. The table has columns for "RESOURCE", "CAPACITY", and time slots: "2:00 PM", "3:00 PM", "4:00 PM", "5:00 PM", and "6:00 PM". Each resource row starts with a checkbox. The 3:00 PM column is highlighted in blue. At the bottom of the window, there are two buttons: "<< Previous" and "Next >>".

RESOURCE	CAPACITY	2:00 PM	3:00 PM	4:00 PM	5:00 PM	6:00 PM
<input type="checkbox"/> Basel-Room ...	0					
<input type="checkbox"/> Espoo - koka	1					
<input type="checkbox"/> Hanoi	0					
<input type="checkbox"/> London Roo...	0					
<input type="checkbox"/> Munich-Roo...	0					
<input type="checkbox"/> Nguyet- per...	0					
<input type="checkbox"/> Nguyet_ps5_...	1					
<input type="checkbox"/> Nguyet_ps5_...	0					
<input type="checkbox"/> Nguy-Pool1(...	6					
<input type="checkbox"/> Oslo - Motel...	0					

Default filter

You can choose which resource categories to display by default. Simply tick on your wanted categories and click [OK].

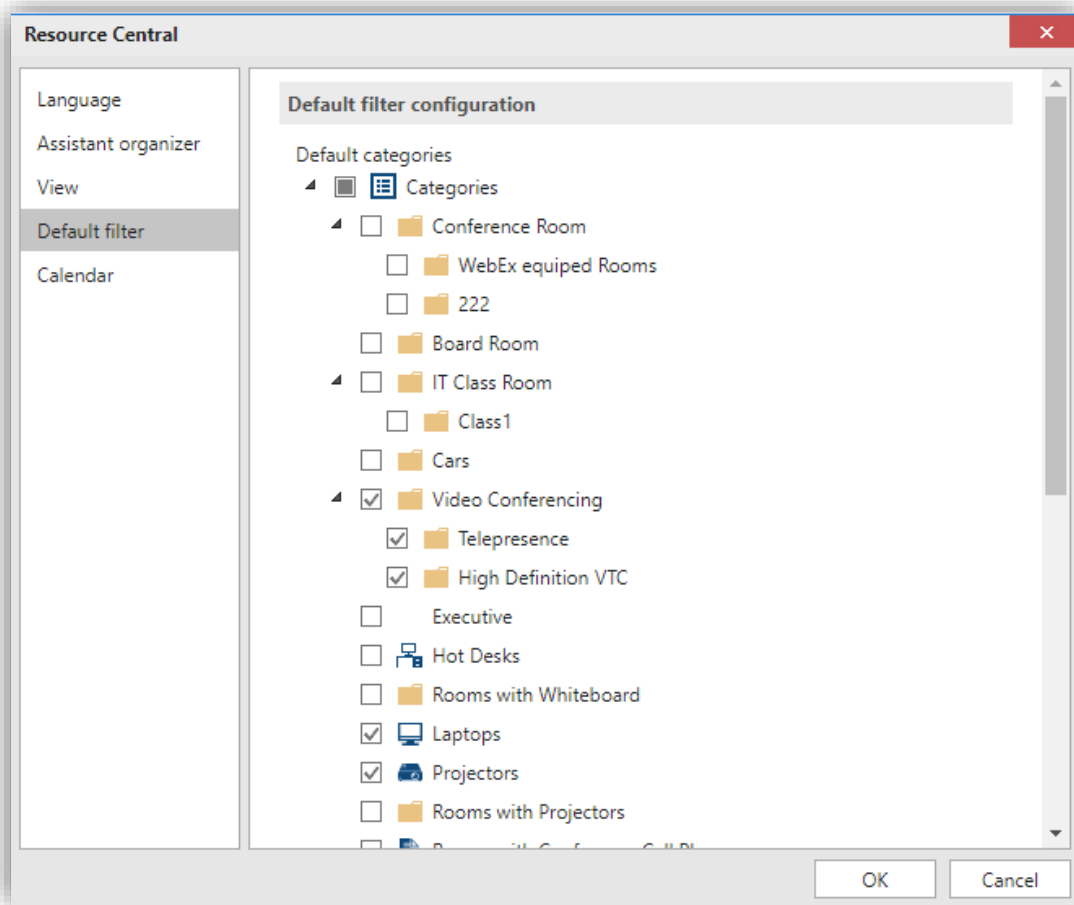

Figure 15. RF Settings – Default filter

Calendar

Here you can select which day will be the first day of the week.

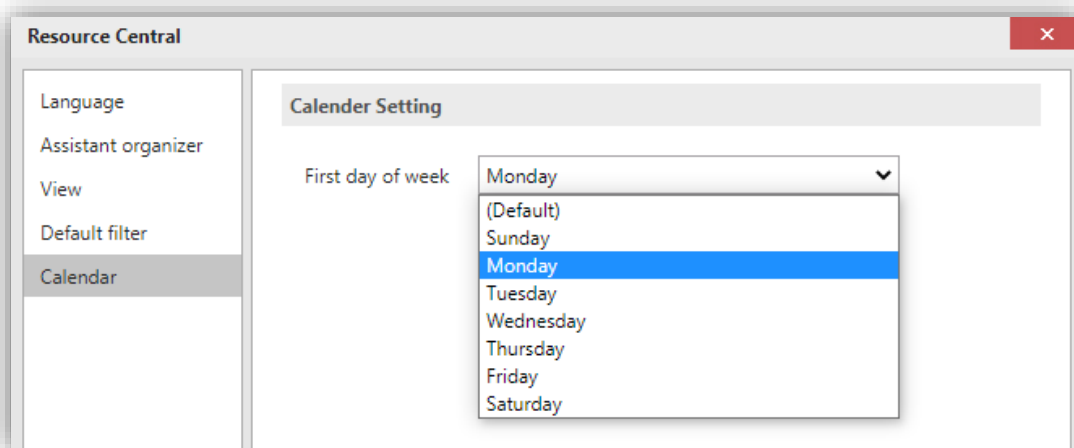

Figure 16. RF Settings – Calendar

Navigation Pane

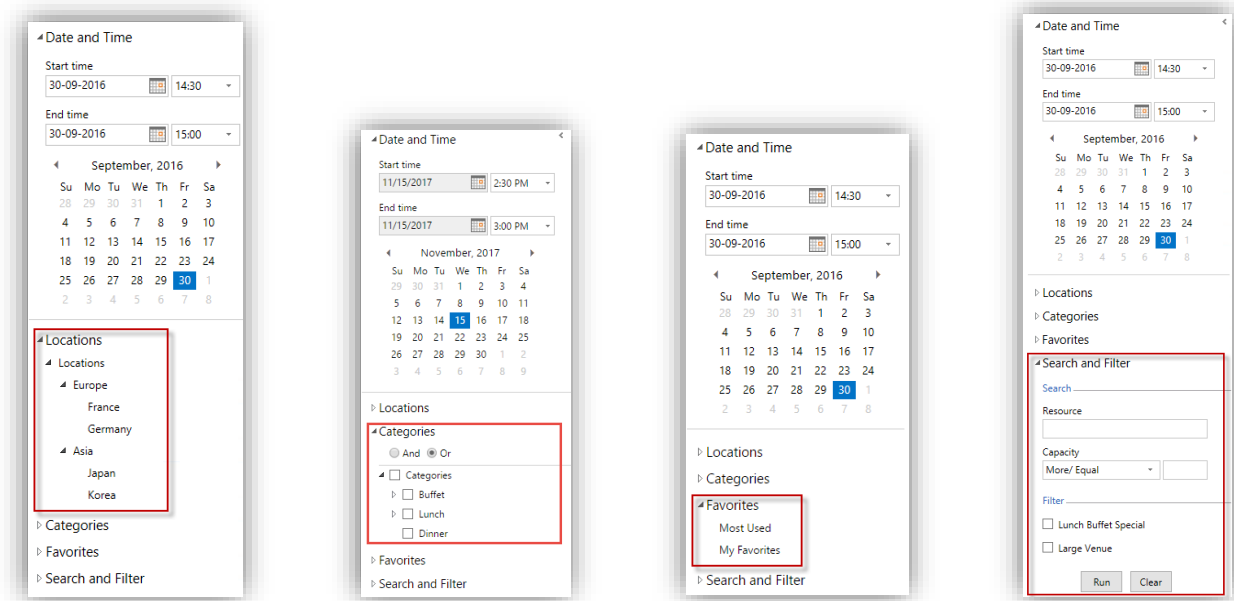

Figure 17. ResourceFinder's Navigation Pane with different view function (Locations, Categories, Favorites and Search and Filter)

ResourceFinder enables users to find a specific resource. All resources are displayed in the Resource Overview section or divided up and displayed according to the selected view function in Navigation Pane. The view function includes:

- Locations
- Categories
- Favorites
- Search and Filter

More detailed descriptions and guide of how to use the above function could be found in corresponding sections in this document.

Floor plan

When booking a resource, it is useful if you can navigate to the resource and see the floor plan / ground map on the screen. The Floor plan section is created to serve that purpose.

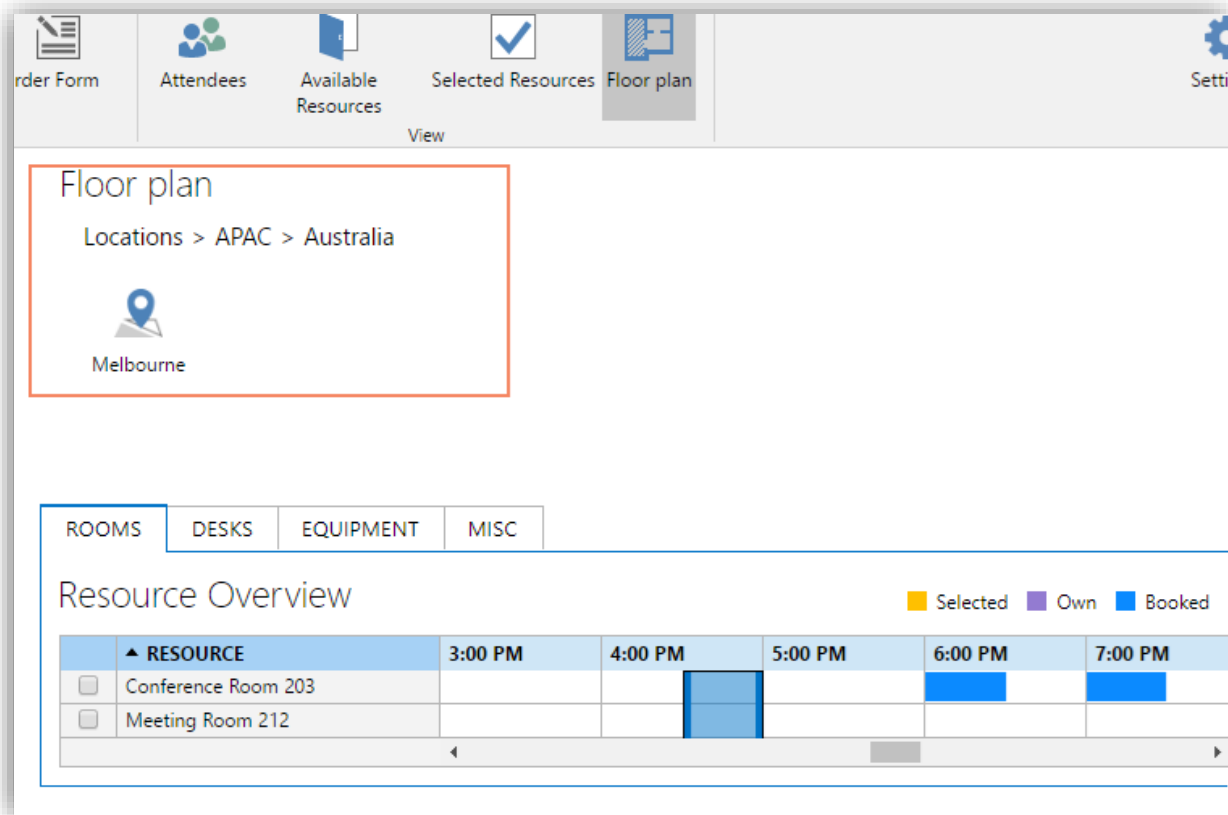

Figure 18. Floor plan enabled

This function is controlled by the parameter **ResourceFinder.FloorPlan**. For more details about this parameter, please refer to **RC Parameter Guide**.

When it is enabled, you can see the **[Floor plan]** button on the toolbar. Click on it, the **Floor plan** section is available on top of **Resource Overview** section:

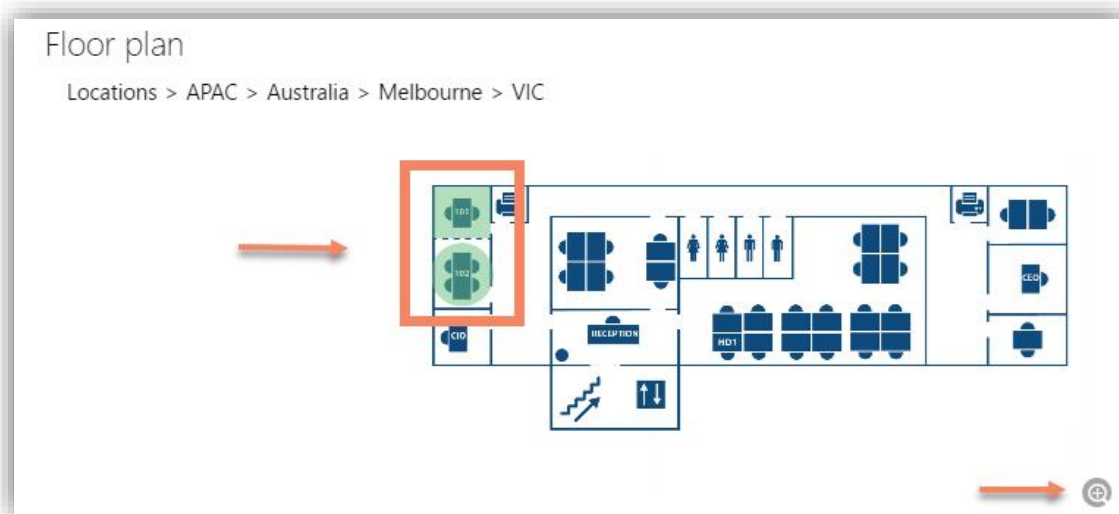

Figure 19. Floor plan display

From the floor plan, you can click on a resource, and this resource will be selected with a checked symbol in the resource list. If you want to see the floor plan in bigger size, click the magnifier button (see the arrow in the screenshot) to enlarge it.

Refer to [Locations](#) section for more details on how to upload the location image, do the resource mapping, use the icons or icon images as part of the navigation.

Resource Overview

When you mouse over a booked reservation, the name of the **Organizer** will be shown in the tooltip of the reservation with a direct link. If you click the link, it will open an **Outlook** email form with the organizer name pre-populated in the form.

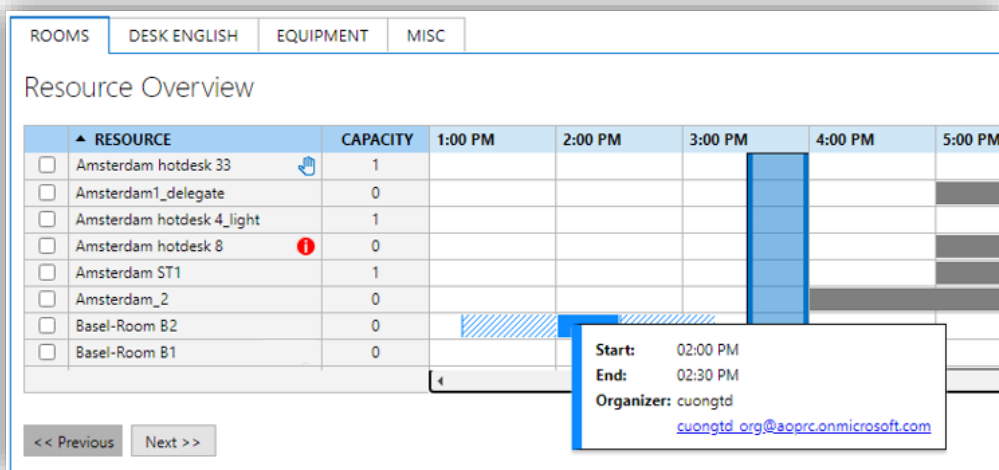

Figure 20. Resource list in ResourceFinder

NOTE: If your company is using booking policies to govern booking of resources, you will see icons next to a resource to know if you can book that resource. See [Permissions service](#) section for more details.

Details

You can **view** a resource's details by clicking on a resource in the resource list. Resource details will be shown in Details section on left side of **ResourceFinder** window.

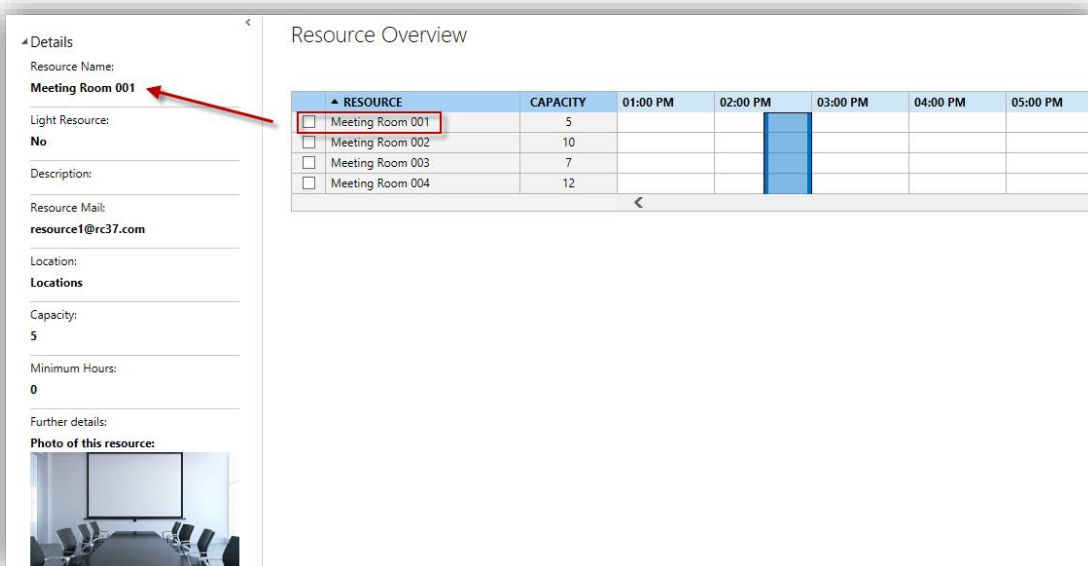

Figure 21. Resource Details

Following detailed information about resource will be shown in **Details** section

Fields	Descriptions
Resource Name	Name of the resource
Description	Description text given in resource details
Resource Mail	Email address of resource set in Exchange Server
Location	Location of resource (if given in resource details)
Capacity	A number indicating the capacity of this resource
Minimum hours	Minimum hours are used to control whether Resource Central Orders will be accepted at a given time or not. If set to a value different from 0, orders will not be accepted if they are posted after this "Minimum Hours" (compared with system current time)
Further Details	Rich text description and any image related to the resource will be displayed here.

Order Form

After selecting a resource or several resources to book for a reservation, click **“Order Form”** button on the toolbar.

The Order Form will be opened to order extra services and add visitor(s) to the reservation from a “one step order form”. In this way, when you actually place the booking, the order would also be placed, thus completes your meeting setup.

PS10_001 NORMAL Order

If you require extra services for your resource booking, please enter the number of deliveries, and fill out this form.

Number of deliveries: 1 Delivery

1st service: Serving 1, 3:30 PM, [10:30 AM] Delivery time at resource's local time

Comments: [Text Area]

Serving 1

Name	Price	Qty
Cocacola	10.00	
Fish	10.00	
item1	10.00	
item2	10.00	
item3	10.00	
item4	10.00	
Menu 3	256.00	
Vegetable	10.00	
Catering Total		0.00

Visitors

Register visitors:

Visit detail

Invitee (Organizer): Mark Olin

Host: [Text Field]

Zones: [Text Field]

Set Escorted for all visitors:

Figure 22. Order Form for one resource with normal order

If you want to have a comment box under the catering section (applicable for normal order form only), you can do that with the parameter **CateringCommentBox**. For more details about this parameter, please refer to **RC Parameter Guide**.

Figure 23. Order Form for several resources with shared order

Status Bar

The Resource Legend is located on the upper right corner of ResourceFinder window.

08:00	09:00	10:00	11:00	12:00

Figure 24. Resource Legend

- **Own:** the resource is booked by current user
 - **Booked:** the resource is booked by another user
 - **Closed:** the resource is closed
 - **Buffer time:** (pre and post) buffer time of each meeting booked with the resource.
- If you are using buffer time on your resources, you can decide whether the buffer time should be displayed highlighted/shaded or similar to the meeting. A highlighted buffer time provides the organizer with a clear overview of where to place a new meeting. The operation of the buffer time is controlled

by the parameter **ResourceFinder.DisplayHighLightBufferTime**. For more information about this parameter, please refer to **Resource Central Parameter Guide**.

ResourceFinder Functionalities

If you have the **Resource Central Add-in** installed, a new button will appear on the **toolbar** whenever you open a meeting. Clicking **ResourceFinder** button will bring up a new screen listing all defined meeting rooms, with a blue bar marking in which period you need a meeting room, as shown below:

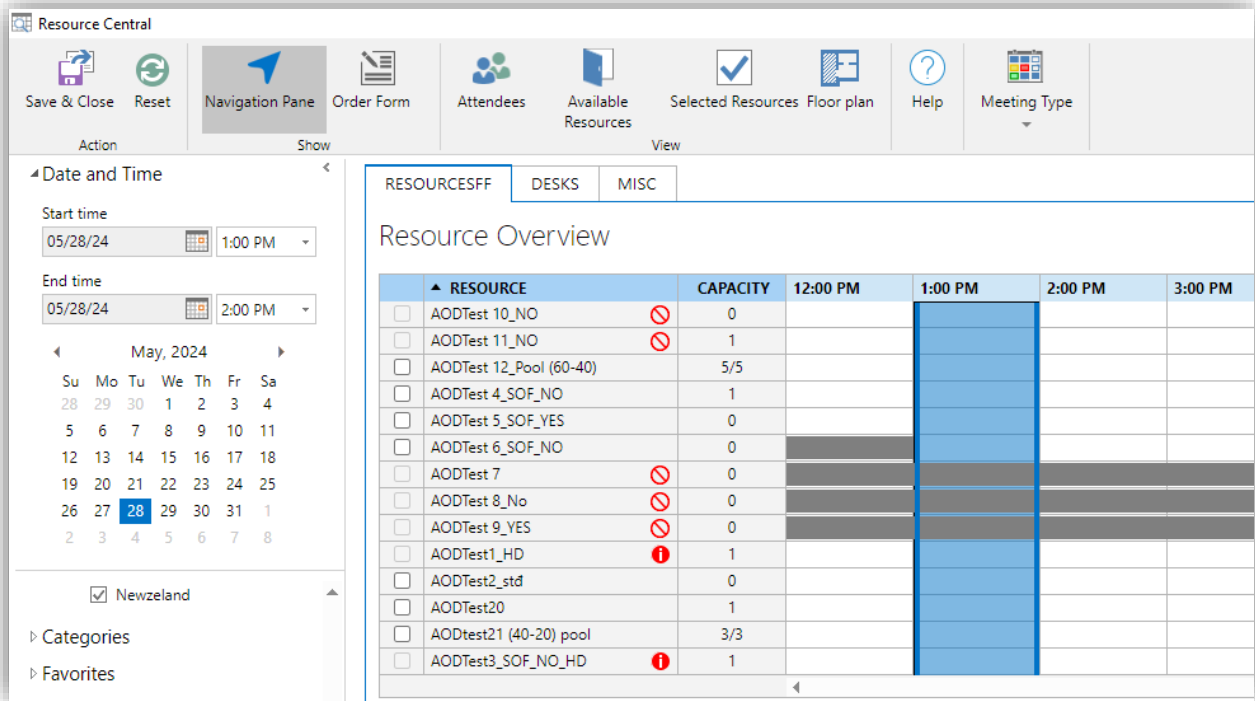

Figure 25. ResourceFinder window

Select Visible Dates in Resource Overview

You are able to view a few adjoining dates in **Resource Overview** section. Please select or drag from-to date in **Date Picker**, then use horizontal scrollbar to view selected dates in **Resource Overview**.

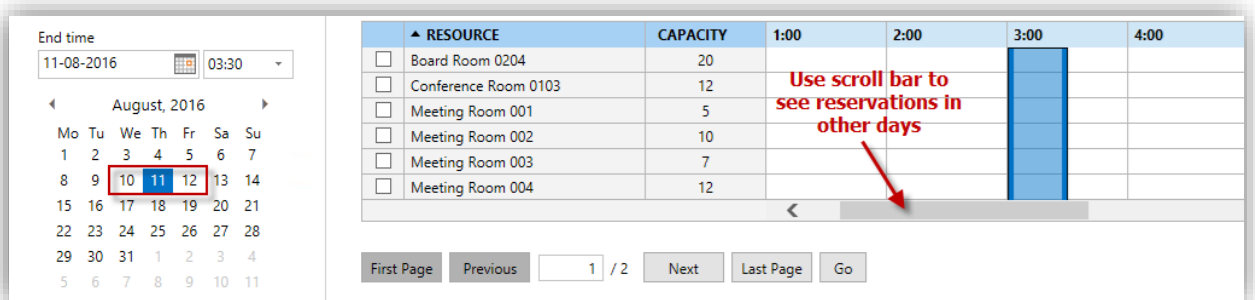

Figure 26. Select Visible Dates in Resource Overview

Select Start Time and End Time

ResourceFinder provides you a flexible way to ensure if your booking time is in available duration. Input **Start Time** and **End Time**, then observe **Resource Overview** section. Your selected time slot will be painted with a colorful range which reflects status for each duration.

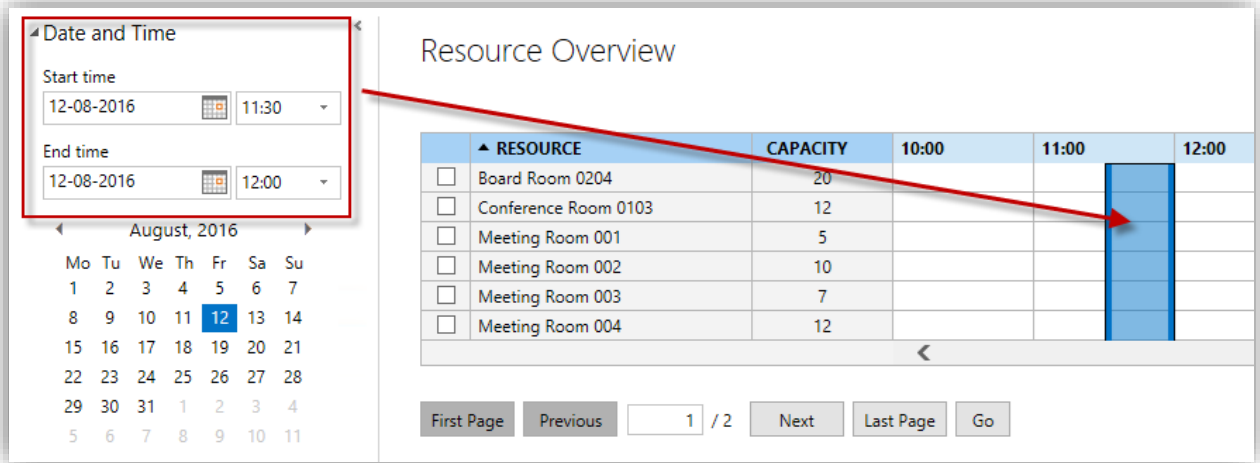

Figure 27. Start and End Time position in ResourceFinder

Tip: Another way to select **Start Time** and **End Time** in **Resource Overview** is to select directly on the timeline. Click on a time slot on the timeline, move the pointer to the **'Start Time'** line (the vertical green line) or the **End Time** line (the vertical red line) so it turns to a two-way arrow, drag it until you have the desired Start Time or End Time. With each dragging step you can select 15, 30 or 60 minutes, which can be configured in the basic parameter **'Time Slot'**.

Display Resources in Resource Overview

Meeting time conflicts, if any, will be shown in the timeline graph against all resources when the meeting start time or end time values are changed; and appropriate message is shown when booked, or conflicted time values are selected in ResourceFinder window.

If you right click upon any of the Location node in the Location tree, you can see **'Set Default Location'** option in the context menu.

You can set a default location so that whenever the ResourceFinder is launched, all the resources belonging to that location node and its children will be automatically displayed in the Resource overview area.

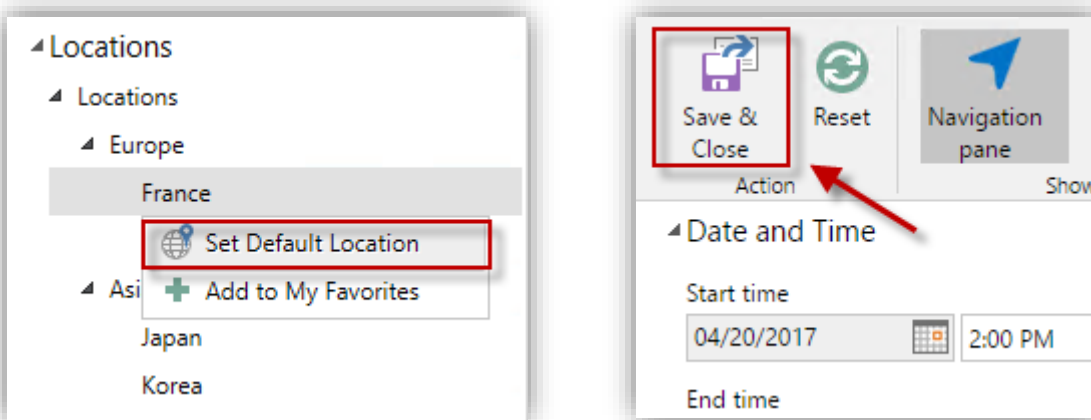

Figure 28. Set Default Location

When you right-click on any of the location/category node in the Locations/Categories tree, click **'Set Default Location'** and then click **"Save and Close"** button, this setting is saved for future use. Now, whenever the ResourceFinder is launched, the specified location node will be selected by default.

If you click the **Available Resources** button, only FREE resources in the selected timeslot will be put on view at the ResourceFinder and the booked resources will not be shown. (For more details about this, please refer to the parameter **"Show.CheckboxAvailableResources"** in **Resource Central Parameter Guide**).

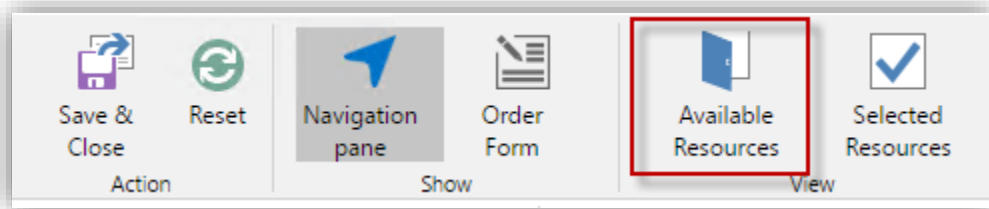

Figure 29. Available Resources Button

Also, the ResourceFinder application will display the resources in Pages. By default, the Paging functionality is ON with Page Size = 40. But you can change the value or turn the functionality OFF. In addition, you can also traverse through the pages with the help of the First, Previous, Next, Last links and Go button. (For more information regarding Paging, please see the details of the parameter **"ResourceFinder.PageSize"** in **Resource Central Parameter Guide**).

Also, as highlighted in the above figure, the column heads of the TimeLine grid are also displaying AM/PM. This would only be displayed if the 12-hour time format value is selected in the **Time Format Basic parameter**.

02:00 PM	03:00 PM

12-hour format

14:00	15:00	16:00

24-hour format

Location

Using the **Locations** section, meeting rooms are presented in a location or category, making it possible for you to find rooms on specific locations, or rooms that meet certain criteria. All resources in child locations of location tree will be shown when parent location in the tree is selected in Locations and Categories tree.

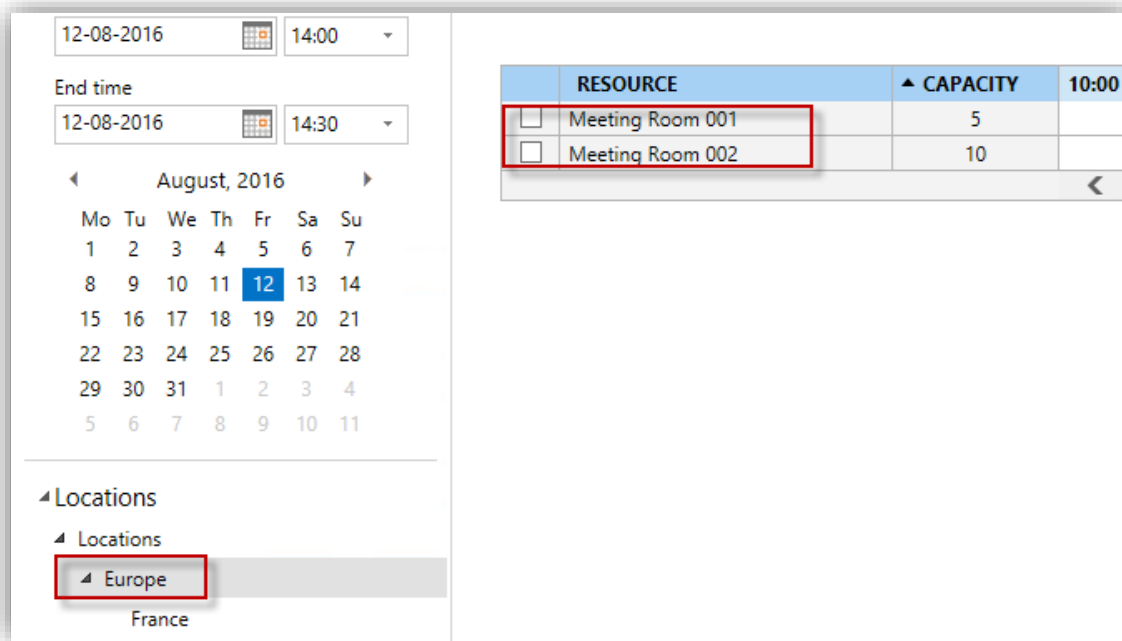
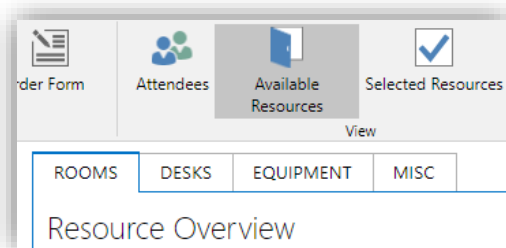

Figure 30. Viewing Resources in Location

Resource Central enables you to make resource selections over multiple location/category nodes. That is, within the current session of the ResourceFinder, you can select resource(s) from multiple location/category(s) and the previous selection(s) would be retained.

In order to assist you in this regard, ResourceFinder features the **Selected Resources** button, clicking which all the selected resource(s) would be displayed in the right pane of the ResourceFinder screen. You can de-select any of the selected resource(s).

Available resources



Selected resources

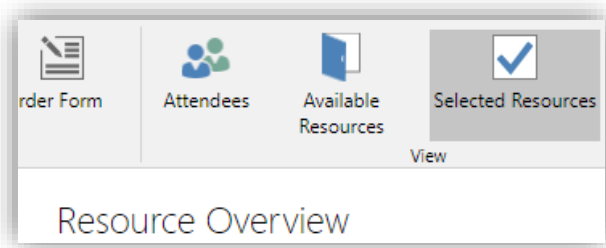

If you want to view resources located at various locations at the same time, you can use “**ResourceFinder.EnableLocationCheckbox**” parameter. A checkbox will show beside the location name, and you can choose one or more locations to view on Resource overview section. (For more details about this, please refer to the parameter “**ResourceFinder.EnableLocationCheckbox**” in Resource Central Parameter Guide).

Categories

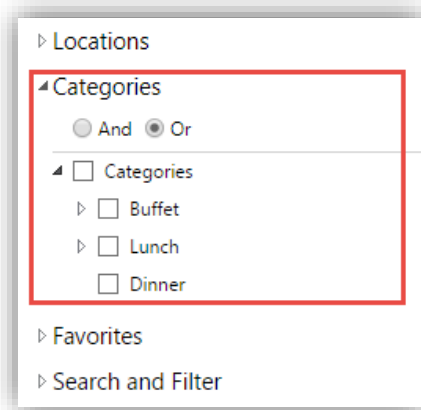

Figure 31. Select more than one category

On the Navigation Pane, click a specific Category to find resources classified into that category. **ResourceFinder** allows users to select more than one category by selecting checkboxes of categories, the corresponding resources will be displayed in **Resource Overview** section.

By default, OR filter approach is selected, i.e., all resources in the checked categories are displayed.

When AND filter approach is selected, only common resources belonging to both categories are displayed.

Favorites

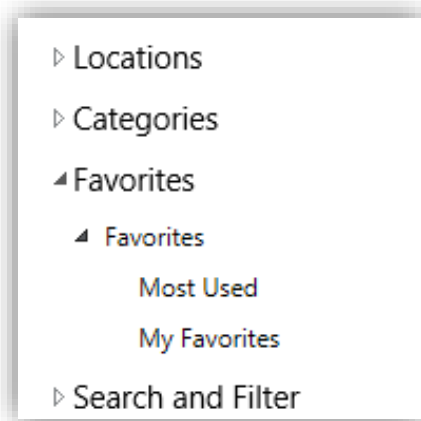

Figure 32. Favorites functionality at ResourceFinder

ResourceFinder application allows you to manage your favorite resources and locations via Favorites functionality. With this functionality, you can have a view of your **Most Used** resources and maintain a customized list of your own **Favorite** resources and locations.

Favorites functionality is only applicable and viewable at the ResourceFinder. It would not be displayed at any other interface of the Resource Central application. At the ResourceFinder, the **Favorites** section is displayed just under the Categories section.

Favorites functionality is controlled by the advanced parameter "**ResourceFinder.FavouriteList**". This parameter can be created at **RC Manager** → **General** → **Parameters** section. The value of this parameter determines the display and impact of the Favorites functionality at ResourceFinder. A brief detail of the values of this parameter is as follows:

Value	Description
0	Favorites List functionality is Disabled. It will neither be viewable nor functional at the ResourceFinder.
1	Favorites List functionality is Enabled. It will be viewable and functional at the ResourceFinder, along with its 2 child nodes namely 'Most Used' and 'My Favorites'. Also note that this is the Default value. If the user has given any invalid value for this parameter, the default value of '1' will be considered.
2	Favorites List functionality is Enabled but its only one child 'Most Used' will be viewable and functional. The other child node 'My Favorites' would neither be viewable nor functional.
3	Favorites List functionality is Enabled but its only one child 'My Favorites' will be viewable and functional. The other child node 'Most Used' will neither be viewable nor functional.

Favorites → Most Used

When you expand the 'Favorites' root node, 'Most Used' is the first child, clicking which, such top ten resources in terms of number of reservations created by this very user who has launched the ResourceFinder, will be displayed in the right pane of the application screen.

By default, 10 resources will be displayed when you click '**Most Used**'. However, this number is configurable, and you can specify any positive integer in this regard. For this, an advanced parameter '**FavouriteList.NoOfMostUsedResources**' should be created at **RC Manager → General → Parameters** section. It should be given a Positive Integer value, which would determine how many top resources should be displayed in the right pane of the application screen. (For more details about this, please refer to the parameter "**FavouriteList.NoOfMostUsedResources**" in **Resource Central Parameter Guide**).

Favorites → My Favorites

With **Favorites** functionality, you are also facilitated to specify your own personal favorite resources. For this, if you want to add a resource or location to My Favorites, please right click on a resource or a location, a menu text with content '**Add to My Favorites**' appears, select it, resource/location will come to My Favorites folder.

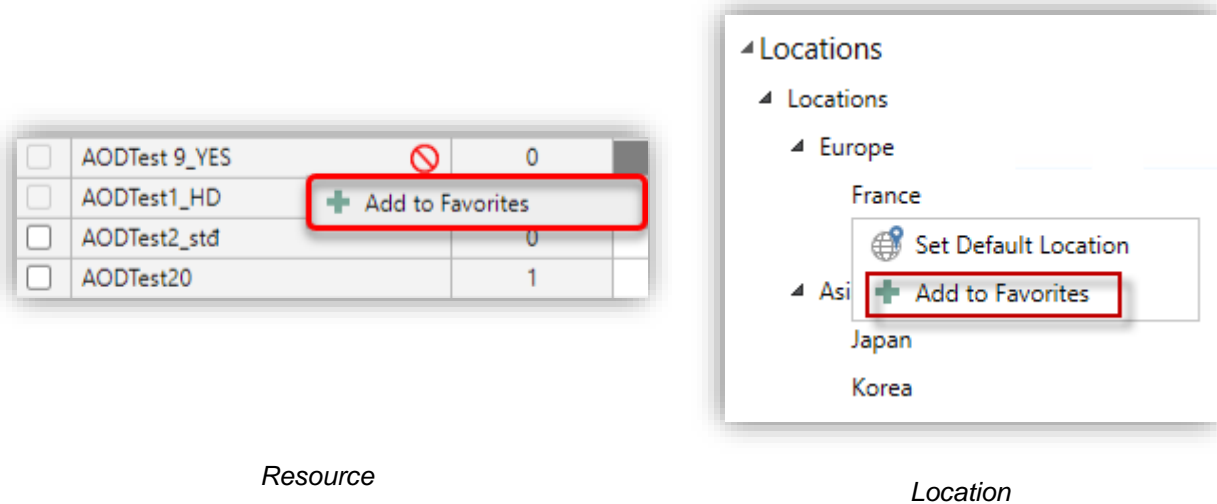

Figure 33. Favorites → Add to Favorites context menu

If a resource/location exists in My Favorites folder, menu text will be '**Remove from My Favorites**'. See these images:

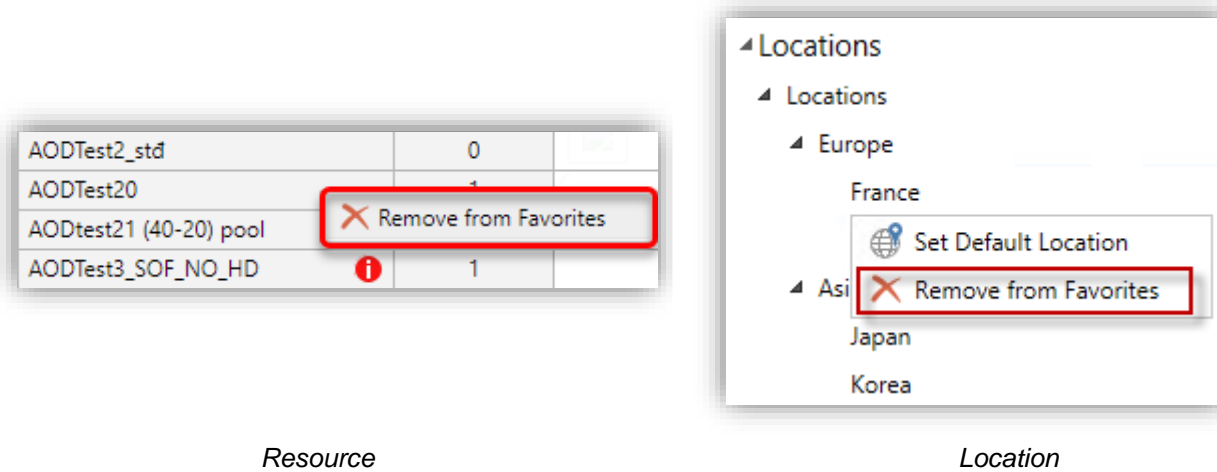

Figure 34. Remove from My Favorites

Now if you click upon the **Favorites** → **My Favorites** node at the ResourceFinder, all the resources and locations that have been explicitly added in the 'My Favorites' list will be displayed on the right pane of the application screen, as shown below:

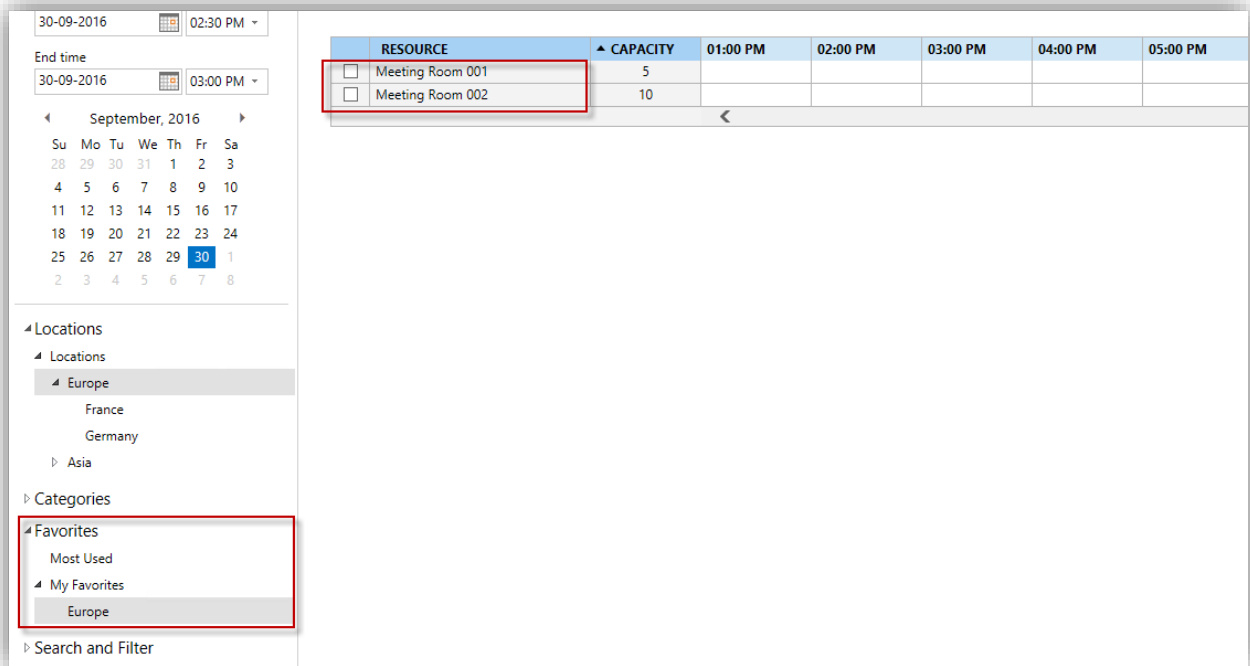

Figure 35. Favorites → My Favorites - ResourceFinder

NOTE: You can right click and select 'Set as default view' on nodes of Most Used or My Favorites. This will bring you more options for the ResourceFinder initial view:

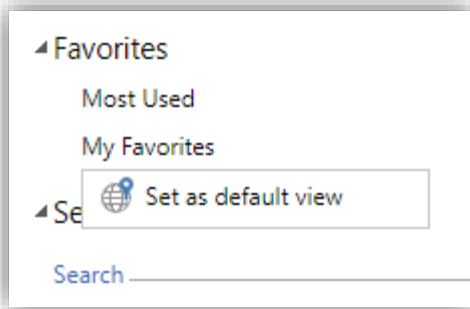

Figure 36. Set default view

After this selection, ResourceFinder will start with a list of the specific resources that you have added to Most Used/My Favorites.

Search and Filter

You can also perform **Search and Filter** or **Search or Filter** operations at the same time by inputting search criteria in Resource Name and Capacity fields and check into available filter. (The ability to apply **Search and Filter** or **Search or Filter** depends on **Filter.AndOr** parameter. For more details, see **Resource Central Parameter Guide**).

Click **Run** button to apply Search and Filter, it will display the result in right frame window.

Using Search functionality

You can search resources in ResourceFinder window by inputting search criteria with **Resource Name** and **Capacity**, click the **Run** button to apply and the result will be shown in Resource Overview area (as shown below):

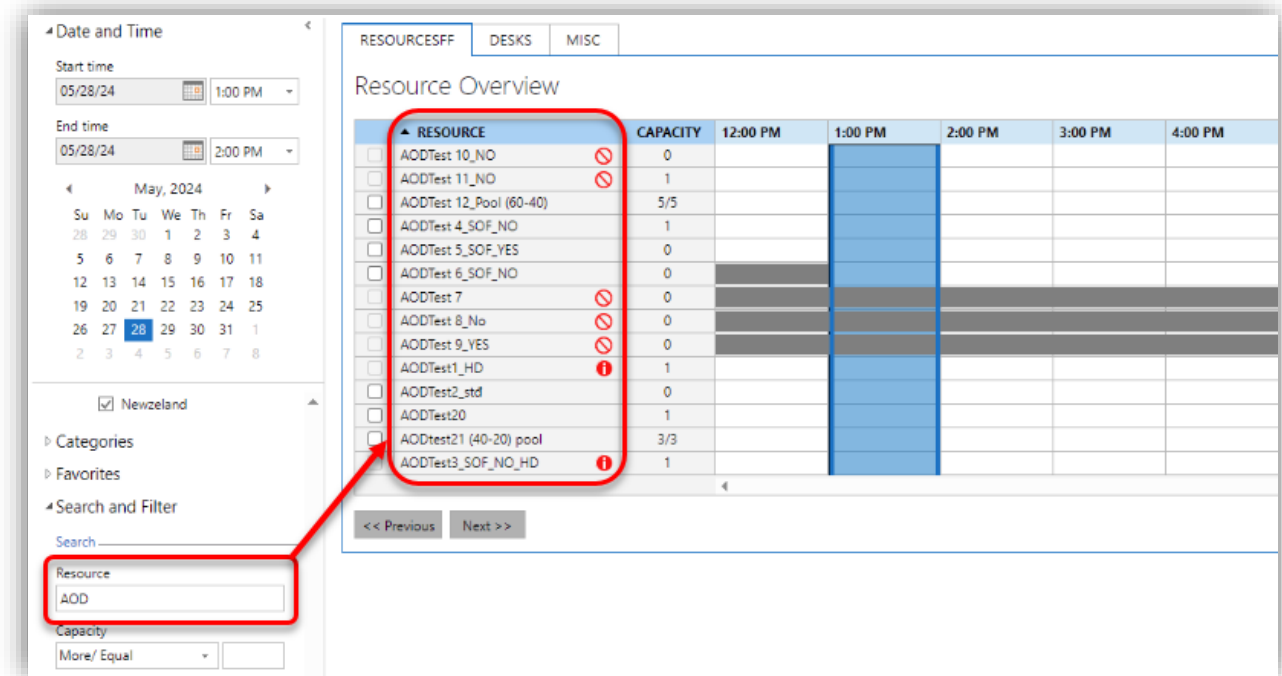

Figure 37. Search

To clear search result, you can click the **Clear** button.

Fields	Descriptions
Resource Name	Enter the resource name to be searched
Capacity	You can enter Resource Capacity value (Positive Integer) values in the text field and by selecting the values in the combo box: Equal: Capacity value equal to the value in text field Less: Capacity value less than to the value in text field More: Capacity value more than to the value in text field Less/Equal: Capacity value less than or equal to the value in text field More/Equal: Capacity more than or equal to the value in text field

Toolbar buttons	Description
Run	Executes the Search criteria given in Resource Name and Capacity fields and show any matching Resource(s) (if any) in the resources list.
Clear	Reset result of searching and filtering.

Using Filter

All available filters created from **Resource Central Administration** page are shown under **Filter** section on task pane as below:

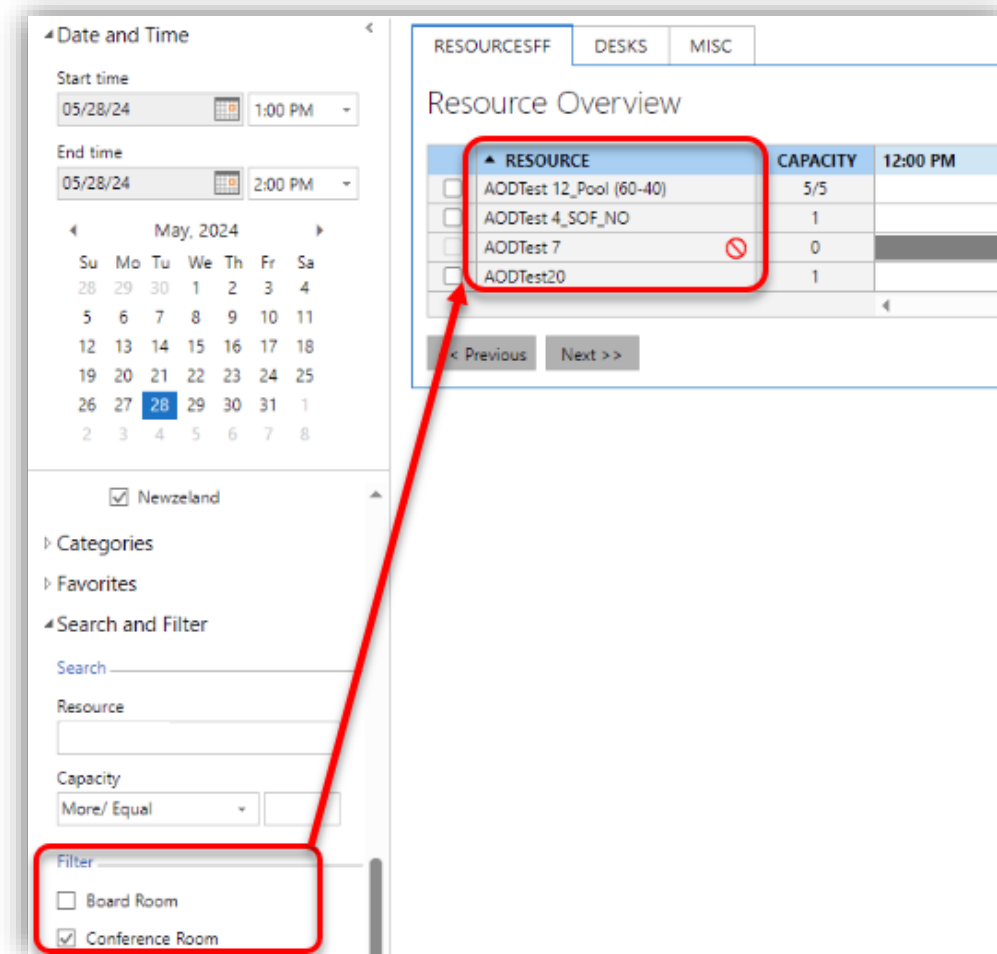

Figure 38. Filter

You can filter the configured criteria list by checking to checkboxes under Filter section and clicking **Run** button. (For filter creation please refer to **Resource Central Admin** → **Designer** → **Filters** section). Click **Clear** button to cancel filtering result.

Toolbar buttons	Description
Run	Executes the filter criteria (selected filters in the list) and displays all matching resources (if any) in the resource list.
Clear	Cancel search and filter result.

One Step Order at ResourceFinder

Resource Central lets you add visitors and order extra services from a “one step order form” including catering, audio visual, transportation, seating arrangements. With this feature, an order is placed at the ResourceFinder for the resource, upon which you would like to make the booking. And so, when you place the booking, your order and visitors are also added, thus saving your time.

How to place a one-step order

Placing order at ResourceFinder is very easy. Launch ResourceFinder and you will see the **[Order Form]** button on the toolbar.

To be able to click the button, you have to select at least one Standard resource (which has 'Light Resource = No' in its details), e.g.:

The screenshot shows a form for 'Meeting Room 001'. The 'Light Resource' field is set to 'No' and is highlighted with a red box. To the right is a table with a header 'RESOURCE' and two rows: 'Meeting Room 001' and 'Meeting Room 002', each with an unchecked checkbox. A red arrow labeled 'Click' points to the 'Meeting Room 001' row.

Figure 39. Light Resource Details

Then click [Order Form] which will open the Order Form of that resource below, e.g.:

The screenshot shows the 'MEETING ROOM 001 Order' form. It includes a section for 'Number of deliveries' (set to 2) and 'Delivery time at resource's local time' with two servings: 'Serving 1' at 10:00 AM and 'Serving 2' at 10:45 AM. Below is a 'Comments' text area. The 'Serving 1' section contains a table of items:

Name	Price	Qty	Quota
Lunch menu	12.00		
Dinner menu	10.00		
Coke	100.00		1078
Coffee	20.00		88
Tea	20.00		1234
Mineral Water	50.00		1234
Macaroncookies 2	10.00		9999
Macaroncookies 3	0.00		1234
Macaroncookies 4	10.00		1234
Macaroncookies 5	10.00		1234
Breakfast menu	10.00		
Special Lunch menu	0.00		

NOTE: Items with icon cannot be booked because the deadline for these items has passed.

Figure 40. Order Form for booking of one and several resources at ResourceFinder

Place the order as per your need and then click **[Save & Close]** to submit your order (please note that until now, your order has been temporarily saved and it cannot be seen in the Resource Central Application until you actually book the reservation):

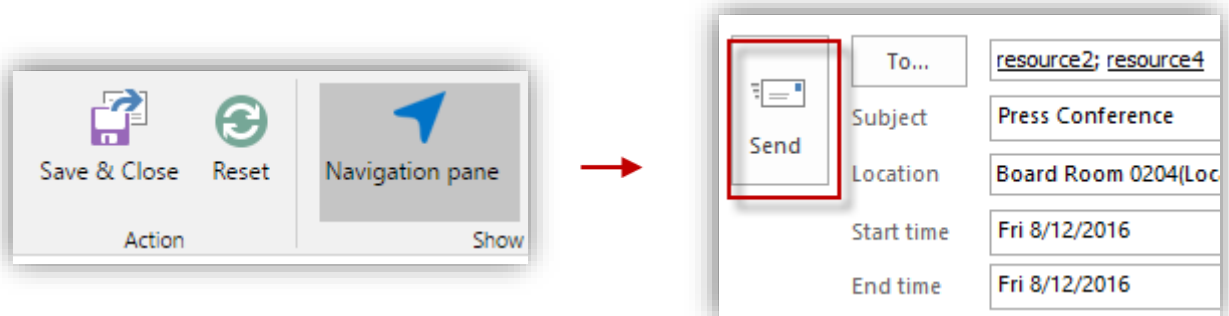

Figure 41. Order Process

You are redirected back to the Meeting window with the selected resource. Clicking **[Send]** at the Meeting window will create the New Meeting and the order would be placed automatically, which will be acknowledged with the 'New Reservation', 'New Order', and 'New Visitors' (if you added visitors in the Order Form) emails. The same is also true for Recurring Reservations.

Limitations of One Step Order

As it is an advanced functionality, so it is subject to some limitations which are discussed here:

1. One Step Order functionality at the ResourceFinder is **only applicable to Standard Resources**. If you select a Light resource (Light resource is such which has 'Light Resource = Yes' in its details) and then click 'Place order', the following warning message will be displayed (same is also true if you have selected multiple light resources and tried to place order):

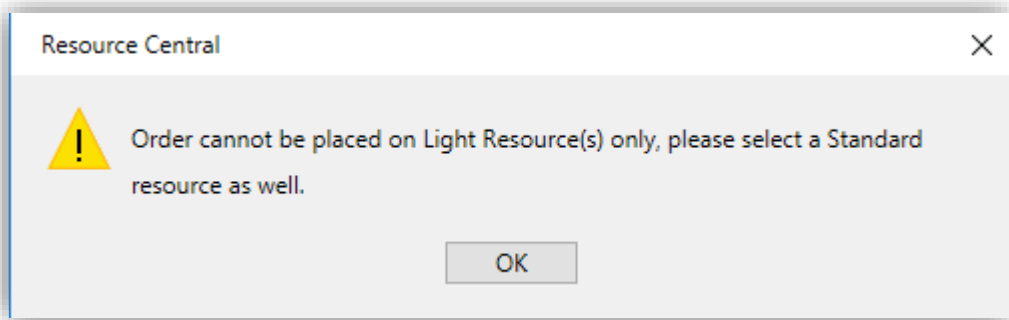

Figure 42. Light resource warning message - One Step Order at ResourceFinder

2. However, if you have made a multiple resource selection including a single Standard and multiple Light resources, and then click **Order Form** then you will be displayed the Order Form of the respective Standard resource.
3. If you need to place order for more than one standard resource in the same session, you can do that sequentially, i.e., you will have to select 'Resource1', click 'Place order', click 'Send order', now uncheck 'Resource1' and check 'Resource2' and follow the same steps to complete the order placement etc.

When you are done, at the Navigation pane of the ResourceFinder, select both 'Resource1 and Resource2' and click the **[Save and Close]** button. This would return the emails of both the resources to the Meeting window. When you click **[Send]**, the meeting will be created on both the resources with individual respective order associated with each.

4. If you have placed the order or made some changes on ResourceFinder, but you accidentally click the **[X]** button to close the window, then you will be prompted as follows, just to make sure that you are aware of what are you doing:

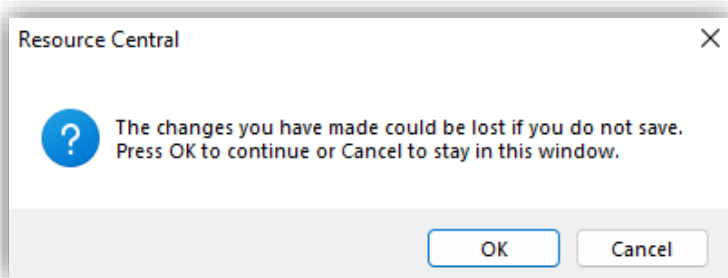

Figure 43. ResourceFinder window close warning message - One Step Order at ResourceFinder

Some additional information regarding One Step order:

While you are placing orders via ResourceFinder, all of this data is actually stored temporarily in some tables of the **RC database**. With the passage of time, the amount of data in those table(s) could exceed such that it could affect the performance of the application.

Adding Attendees in the Meeting window

ResourceFinder will only display the information of those attendees that has been explicitly added in the 'Required' field of the Meeting window. The recommended way to add them is by clicking "To", selecting them, and then clicking the [Required] button.

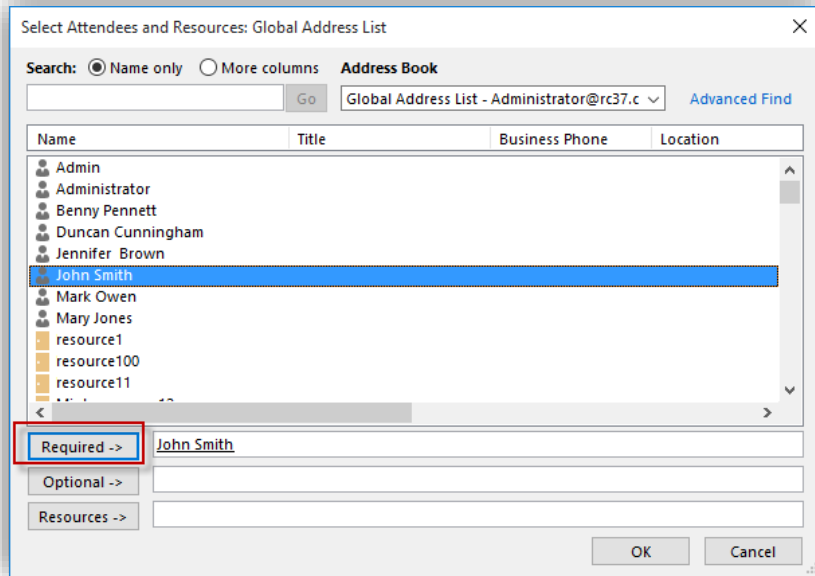

Figure 44. Select Attendees from the list to add

However, you can also type in the complete email address in the 'To' field of the Appointment window (as highlighted below), but after that you should wait for a while to get that email resolved.

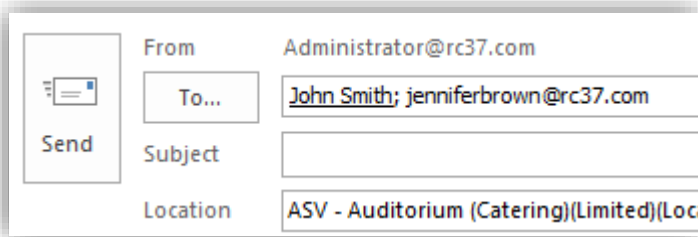

Figure 45. Manually typing the email address in the Appointment window

As soon as the email address or its name is resolved, it becomes under-lined (as highlighted in the figure below)

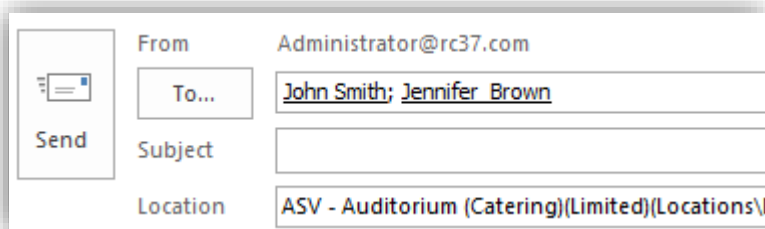

Figure 46. Typed Email address is resolved in the Appointment window

Another approach in this regard could be to click the **Scheduling Assistant** button over the Appointment window. By doing this, all the corresponding email address(s) would be automatically resolved.

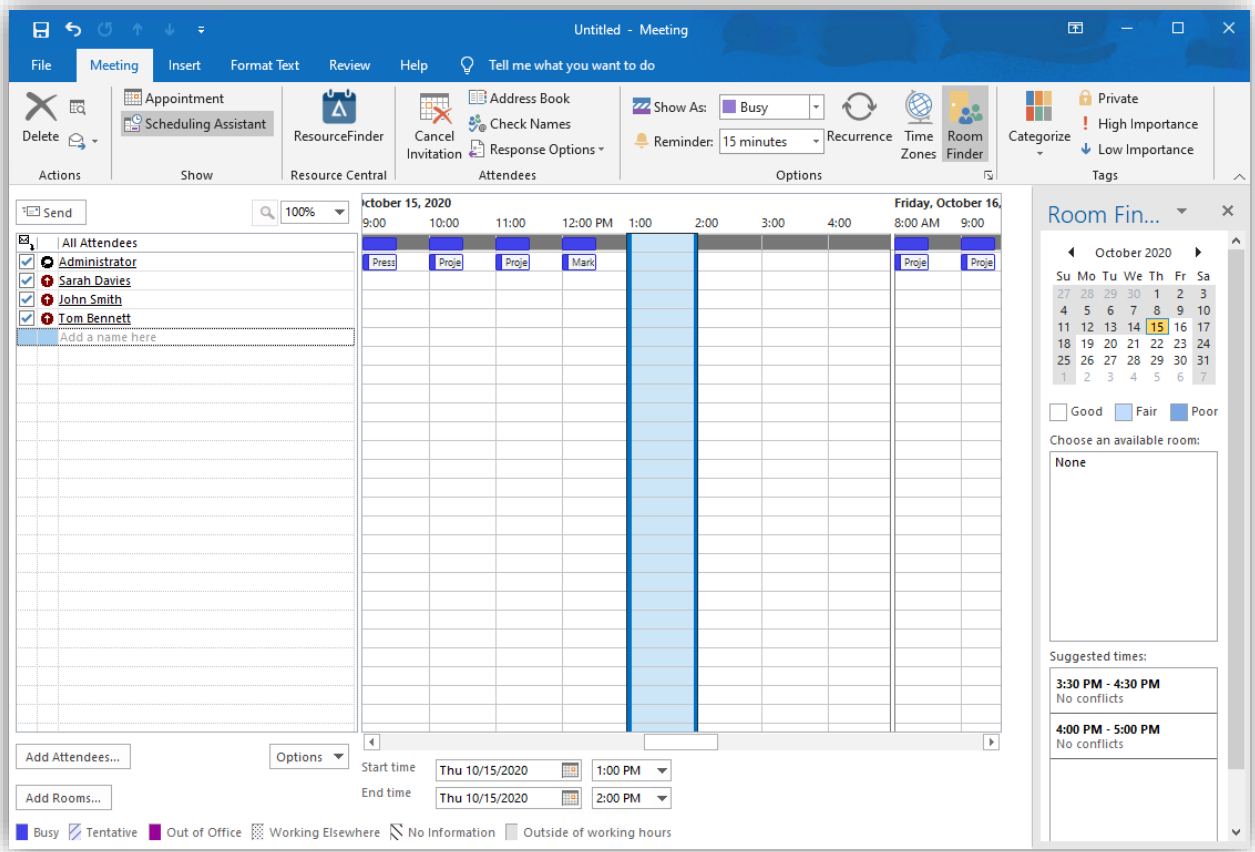

Figure 47. Scheduling tab view in the Appointment window

When you receive the New Reservation Email as per the reservation and you navigate to the Order form of this reservation, you will see that the added attendees have already been listed in the order form, under the 'Attendees' section. When you click 'Send Order' at the order form, the respective attendees will be associated with the reservation and will be available to be viewed at all the respective interfaces of the RC application.

Aside from adding attendees in the Meeting window, you can also add visitors directly via Order Form (refer to **Order Form** → [Visitors](#) section for more details).

Making a Meeting Reservation using ResourceFinder

To make a reservation using ResourceFinder, follow the steps below:

1. In the Outlook window, click **New appointment** and specify needed information for the reservation.
2. Click **Invite Attendees** button and click 'To' to select attendees.
3. Click **ResourceFinder** button and select the resource(s) you want to book.
4. Click **Order Form** button in the toolbar to order additional services.
5. Click **Save and Close** to save the information and navigate back to the new appointment window.
6. Click **Send** to place the reservation and the order if any.

Detailed guide of how to perform these steps has been described in the corresponding sections above in this guide.

NOTE: Only appointments with BUSY/OUT OF OFFICE/ WORKING ELSEWHERE status are considered as RESERVATIONS.

Making a Meeting Reservation using Outlook

If you do not have the **Resource Central Add-in** installed, you will need to find meeting rooms directly from your Outlook Address List.

Depending on your Outlook version, the “**Select Attendees and Resources**” dialogue will have different looks and feels.

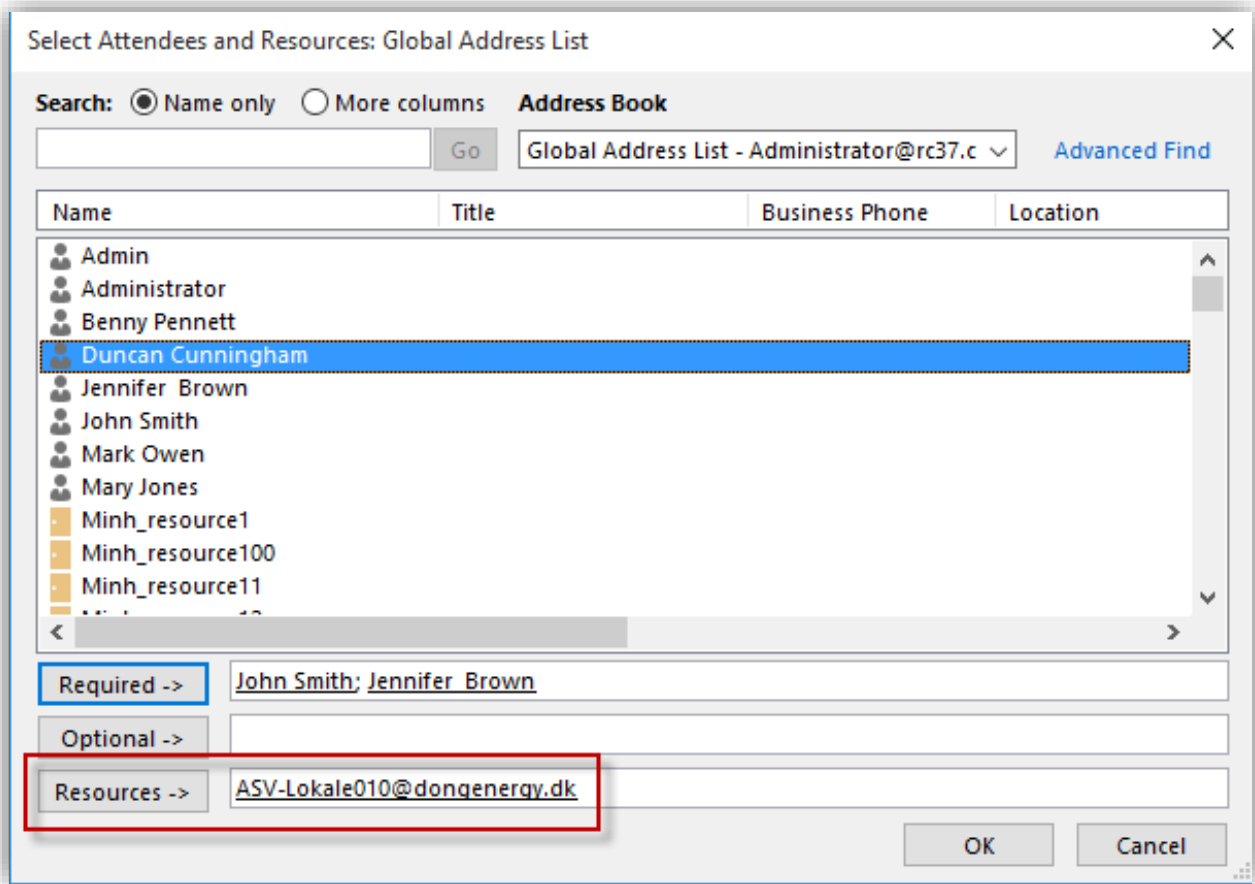

Figure 48. Using the Outlook Address List

Use the address book to select the meeting room and add the room to the list of resources.

If a **Meeting Organizer** successfully makes a reservation of a resource, an e-mail will be sent to him/her. This e-mail contains a link to an order form produced by **RESOURCE CENTRAL**.

Making a Recurring Meeting Reservation

MS Outlook provides you with the option of creating a Recurring Appointment. On the Appointment window, button “Recurrence” is present as shown below:

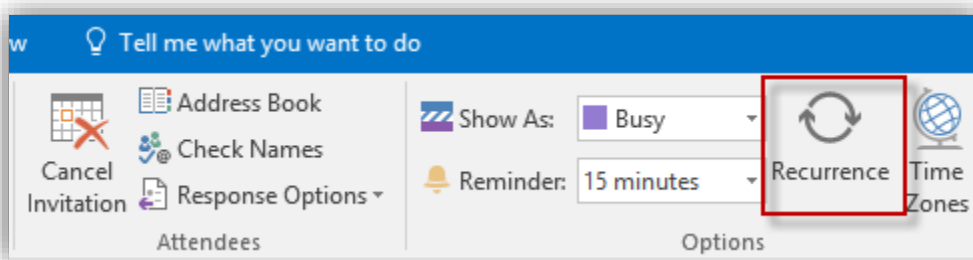

Figure 49. Appointment Window in the Outlook

When you click “**Recurrence**” button, the “**Appointment Recurrence**” window will open:

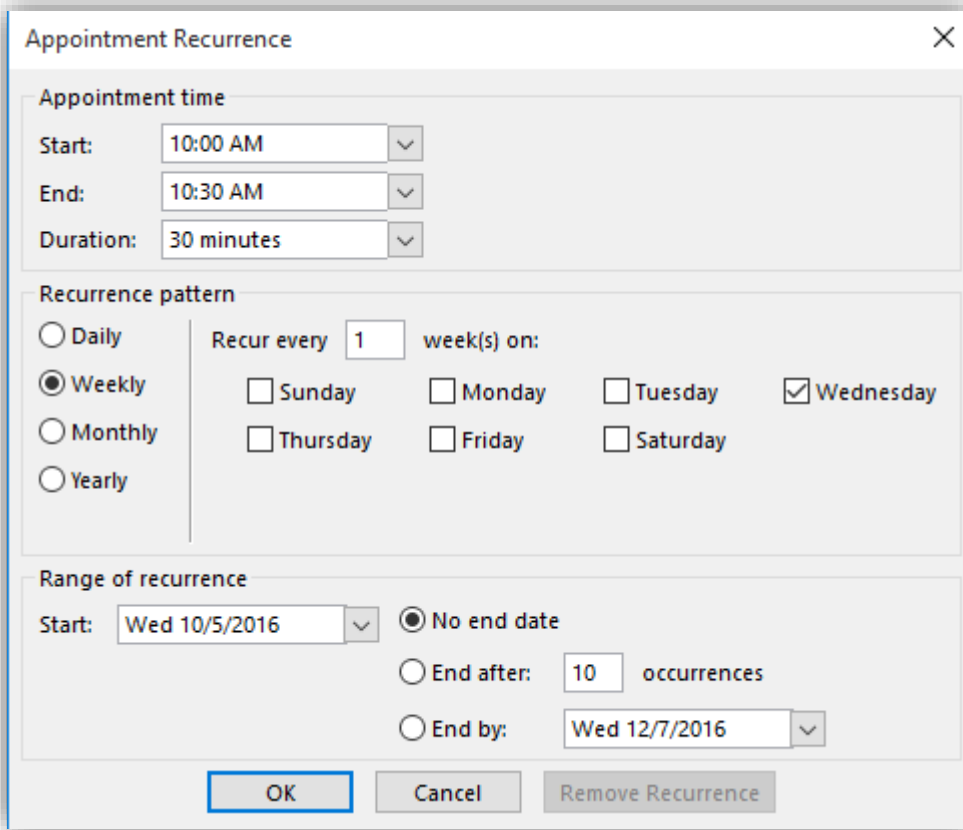

Figure 50. Appointment Recurrence window in Outlook

As you can see in the above figure, you can define any kind of Recurrence from this window. Resource Central deals with all kinds of defined recurrences. The above figure is divided into three sections, each of which is briefly described as under:

- **Appointment time**

In this section, you can define the Start time, End time and the Duration of the Appointment.



Figure 51. Appointment Time

If you change the **Appointment time** of an already placed Recurring Appointment Series, then you will receive a **Changed Recurring Reservation Email**. If order has also been placed, then all the Service Providers will also get the corresponding Changed Recurring Reservation Emails.

- **Recurrence pattern**

Figure 52. Recurrence Pattern

You can define any of the Daily/Weekly/Monthly/Yearly Recurrences, with the customized options available in each of them.

If you change any detail in **Recurrence Pattern** for an already placed Recurring Reservation Series, all these reservations will be deleted and recreated with new detail(s), and RC will send:

- Cancellation Reservation email(s) to reservations with order (number of emails depends on number of cancelled reservations with order).
- Changed Recurring Reservation email (one email only)

- **Range of Recurrence**

Figure 53. Range of Recurrence

NOTE: A change in any of the following, for an already placed Recurring Series, would result in the form of a Changed Recurring Reservation Email to the organizer (and the Service Provider as per order details).

Start specifies the date from which the Recurring Series is to be started

End After (Number of) Occurrences specifies the Total Occurrences/Instances of this Recurring Series

End by (Date) specifies the End of the Recurring Series

No end date specifies that this Recurring Series is to be created with No End, which is executed by RTS.

NOTE: Even when “No end date” option is selected for Range of recurrence, RTS will only synchronize a certain number of records to the database. The number of records will be based on selection user has made in “Recurrence pattern” section, which is defined in RTS (Refer to **Real Time Service User Guide** for more details).

E.g., If user selects “Weekly” in “Recurrence pattern” section, and the default value for weekly appointment recurrence in RTS is 312, then 312 records will be synchronized for this appointment.

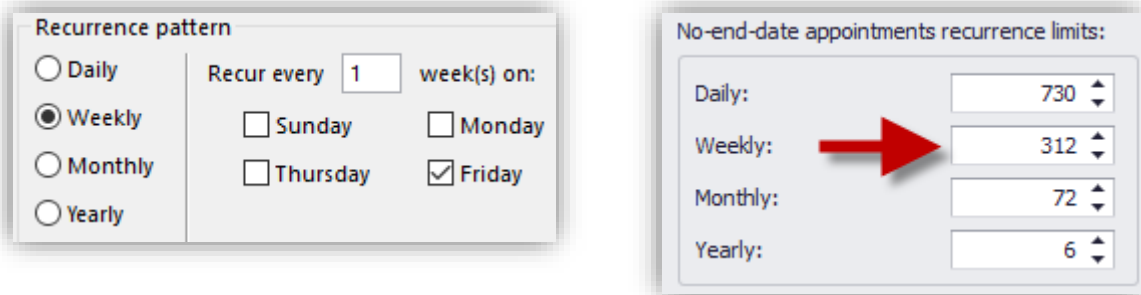

When you click ResourceFinder to select a resource, you can see the availability of all resources for the recurring booking:

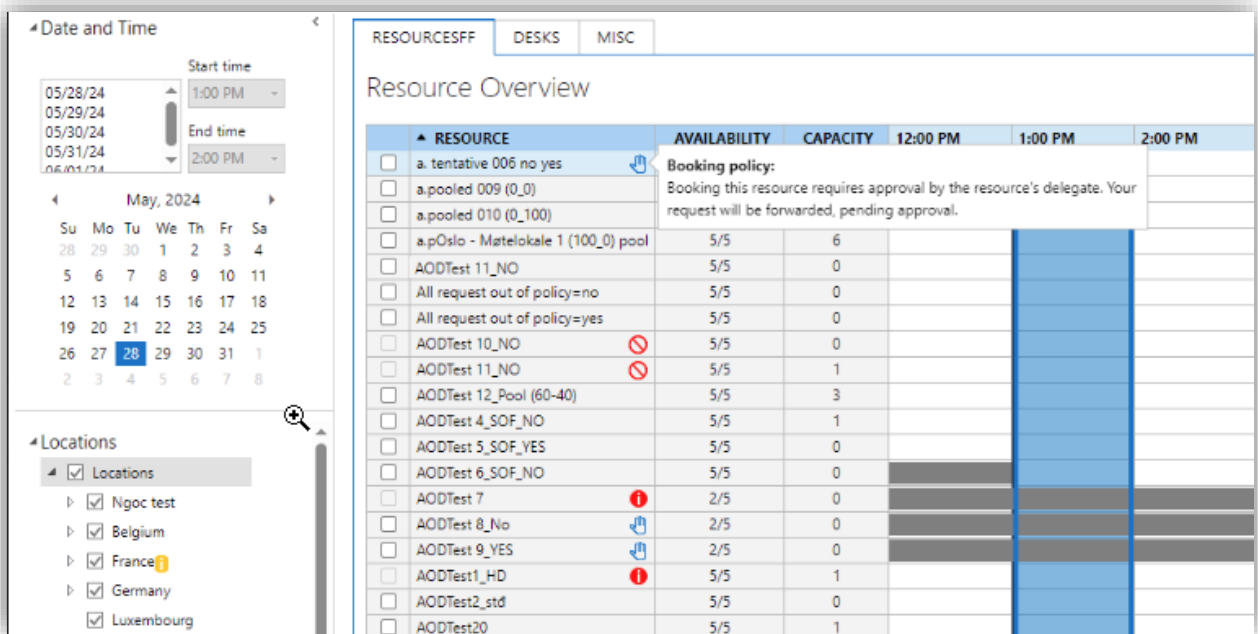

Figure 54. Booking a recurring meeting

Number of available occurrences in a series can also be displayed in AVAILABILITY column. This column is controlled by the parameter **ResourceFinder.ShowRecurringAvailability** (for more details, please refer to **RC Parameter Guide**). After being enabled, the AVAILABILITY column will show up as in the following figure:

The screenshot shows a 'Resource Overview' table with the following columns: RESOURCE, AVAILABILITY, CAPACITY, 11:00 AM, and 12:00 PM. The AVAILABILITY column is highlighted with a red box. The table lists various resources with their availability status (e.g., 85/85) and capacity. The resource 'Bergen - Møtelokale 1' has a red 'i' icon next to its availability status (84/85) and shows a blue bar in the 11:00 AM and 12:00 PM columns, indicating a conflict.

	RESOURCE	AVAILABILITY	CAPACITY	11:00 AM	12:00 PM
<input type="checkbox"/>	Thomas 4	85/85	30		
<input type="checkbox"/>	Thomas 5 (Delegate)	85/85	20		
<input type="checkbox"/>	Toronto	85/85	4		
<input type="checkbox"/>	Toronto - Car 1	85/85	7		
<input type="checkbox"/>	Toronto - Hotdesk	85/85	1		
<input type="checkbox"/>	Vancouver - Car	85/85	4		
<input type="checkbox"/>	Vancouver - Laptop	85/85	1		
<input type="checkbox"/>	Vancouver - Room 2	85/85	30		
<input type="checkbox"/>	Zurich-Room A10	85/85	20		
<input type="checkbox"/>	Tickets	85/85	4		
<input type="checkbox"/>	Bergen - Møtelokale 1	84/85	16	Blue bar	Blue bar

Figure 55. Availability column enabled

You can see the resources with NO conflicts have no 'i' icon next to them, and you can book them for the recurring meeting.

Resources with 'i' icon next to them have conflicts with the booking conditions you selected. And if you mouse over the letter 'i', it will show you more information:

- You can still book resources with **i** next to them using [Alternative Resource](#) feature explained below.
 - o If you book resources with **i** without Alternative Resource, occurrences with conflicts will be rejected by Exchange and need to be rescheduled.
- You cannot book resources with **i** next to them because the booking does not comply with the resource booking policies set up on the resource in Exchange.

Alternative Resource for recurring meeting

You can immediately see what conflicts will occur when booking a recurrent meeting, and you can select alternative resources for those conflicts.

NOTE: This feature does not work if the meeting has multiple resources selected.

The feature is controlled by parameter **ResourceFinder.Recurring.EnableAlternative**. By default, this feature is turned off (Refer to **Resource Central Parameter Guide** for more details).

When the meeting invite is sent and Exchange has accepted the series, Resource Central will replace the occurrences with resource conflicts (with the Alternative Resources). It's important to note that the feature requires impersonation rights on the user calendars for Resource Central to replace the declined resource of the Outlook Meeting.

Follow the instructions below to select Alternative Resources:

1. When you see **i**, hovering on the icon will inform you about the conflicts, as well as the exact occurrences (conflicting dates):

RESOURCE		AVAILABILITY	CAPACITY	1:00 PM	2:00 PM
<input type="checkbox"/>	London 034 + 164	8/8	25		
<input type="checkbox"/>	London 161 + 162	i 6/8	25		
<input type="checkbox"/>	Amsterdam 161	i 6/8	25		
<input type="checkbox"/>	Amsterdam 167	i 8/8	25		
<input type="checkbox"/>	Berlin 117	i 7/8	25		
<input type="checkbox"/>	Stockholm 165	i			
<input type="checkbox"/>	Stockholm 189 delegation 305A5	i			
<input type="checkbox"/>	Stockholm 170 + 178	i			
<input type="checkbox"/>	Paris 205				
<input type="checkbox"/>	Paris 204	i			
<input type="checkbox"/>	Paris 203 + 202	i			

Stockholm 165 tooltip:
This resource can be booked. Be aware that the resource will not be booked on the occurrences with conflicts.

Stockholm 170 + 178 tooltip:
Available occurrences of the series: 5/8

Paris 204 tooltip:
Conflicting Occurrences:
- 3/14/2022 (Closed)

Paris 203 + 202 tooltip:
- 3/16/2022 (Closed)

Figure 56. Occurrence conflicts

Selecting the resource will prompt a note message, e.g.:

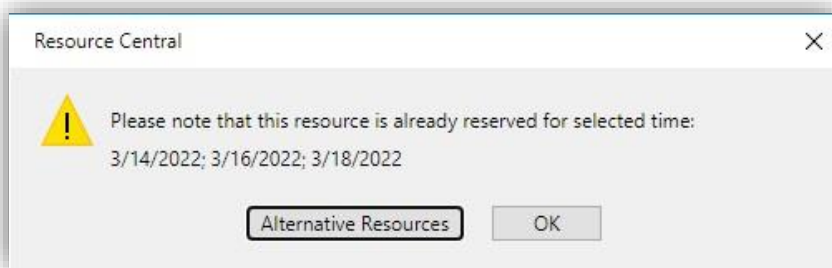

Figure 57. Alternative resource message

2. Click [**Alternative Resources**] to open the Alternative Resources panel. If you click [**OK**] or close the message, the [**Alternative Resources**] button will also appear on toolbar:

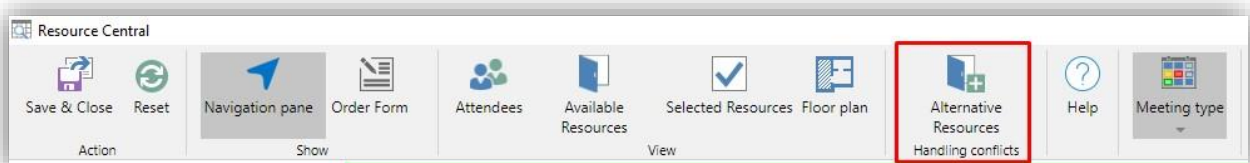

Figure 58. Alternative Resources button on toolbar

The Alternative Resources panel can be seen as follows:

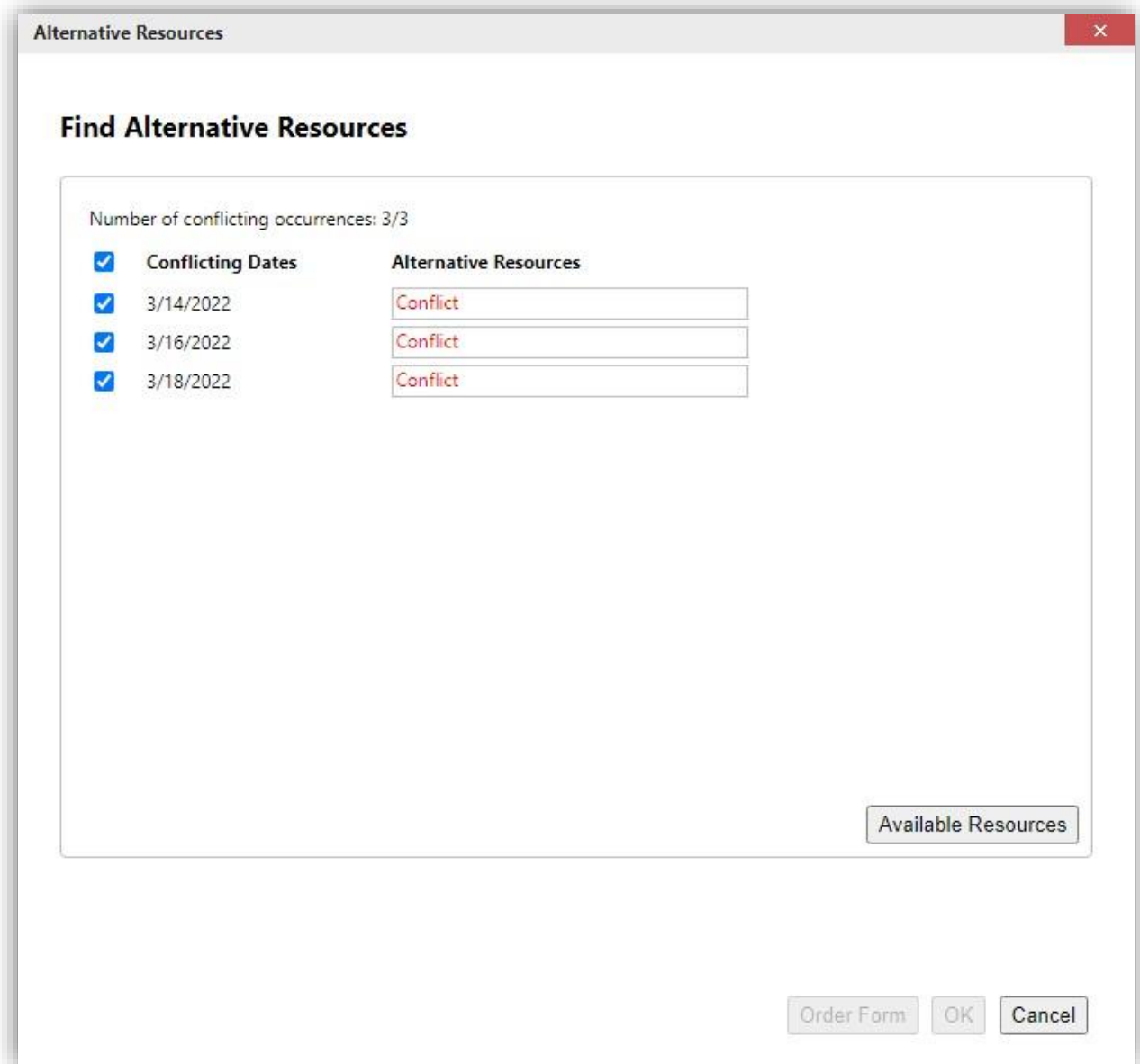

Figure 59. Alternative Resources panel

3. Select the Conflicting Dates that show 'Conflict' status in Alternative Resources row, then click [Available Resources] to open the resource list:

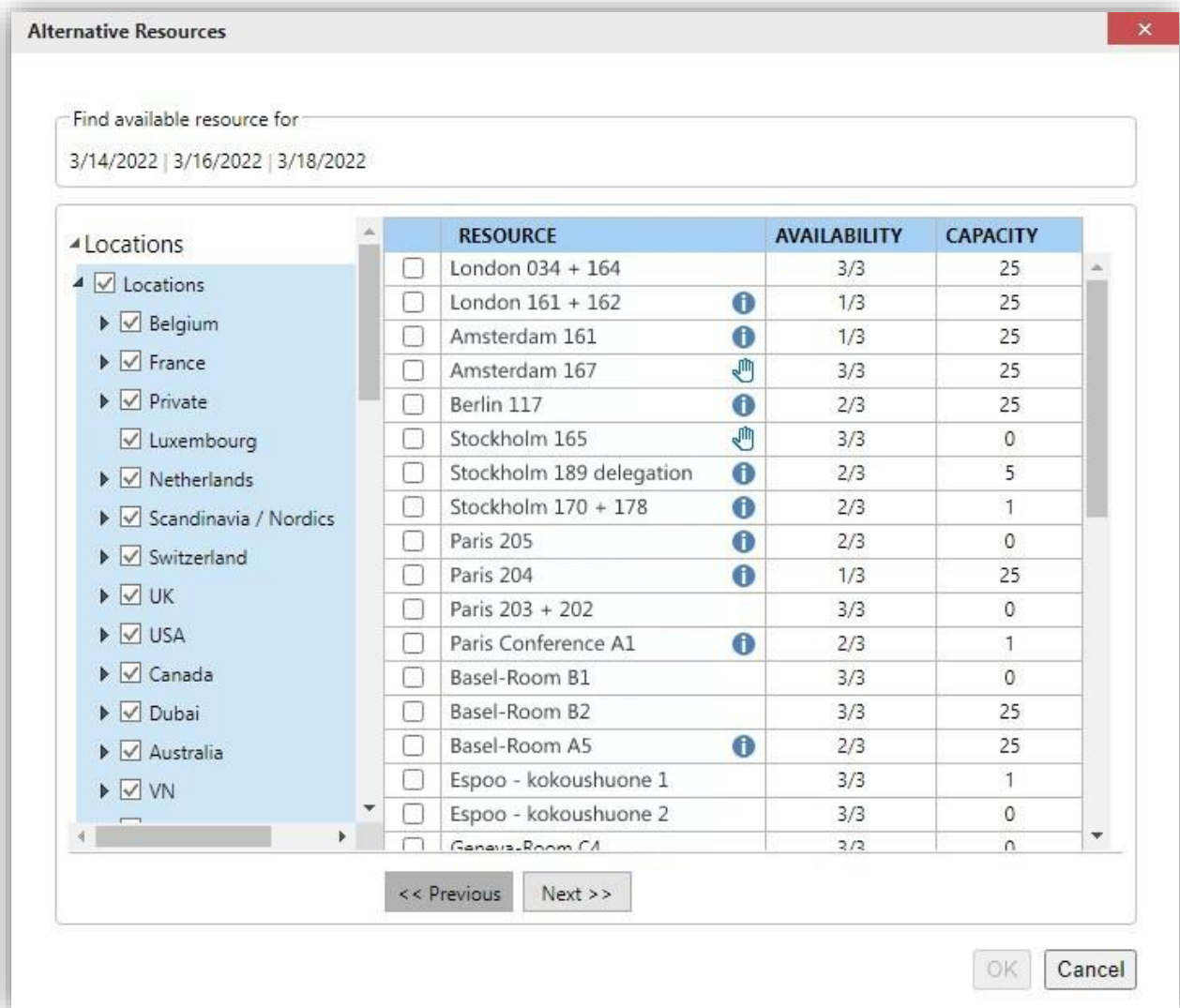
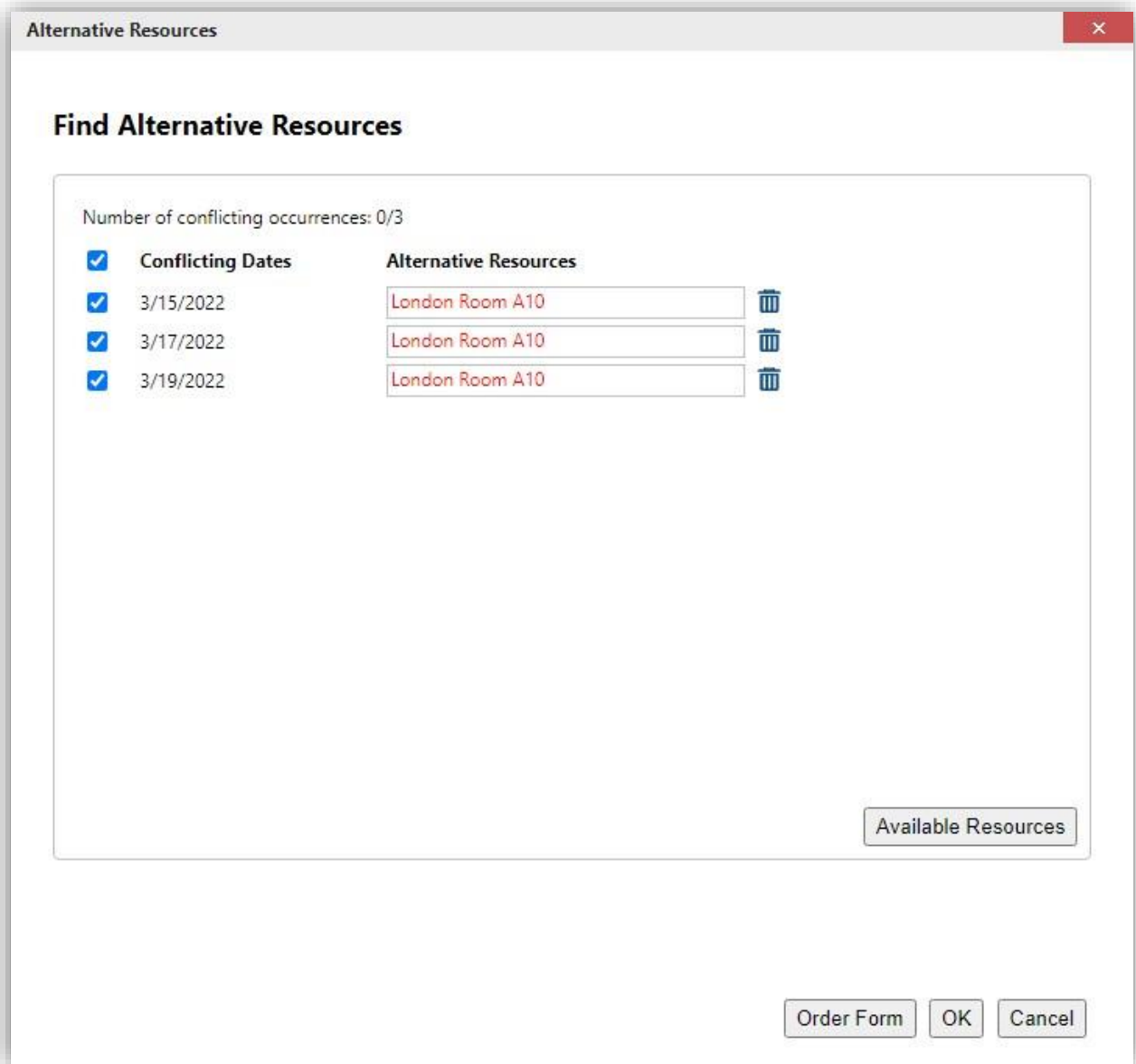

Figure 60. Alternative resource – resource list

Here you can select a new resource to replace the conflicting one, then click **[OK]** to bring you back to Alternative Resources panel. There you will see the new resource selected for the conflicting dates. E.g.:



Here you can also click **[Trash]** icon to remove the respective alternative resource. It will revert the conflicting date back to **'Conflict'**, allowing you to change resource for that date.

NOTE:

- If there is still conflicting date(s) with **'Conflict'** status even after selecting alternative resource, you have to select another resource for those dates that still have conflicts.
- If you select both date with **'Conflict'** status and date with a new alternative resource, or dates with different Alternative resources the **[Available Resources]** button will become unavailable.

4. Click [**Order Form**] to order additional services for each resource you have selected. The Order Form panel will let you order services for all selected resources (including the first one selected on ResourceFinder's resource list):

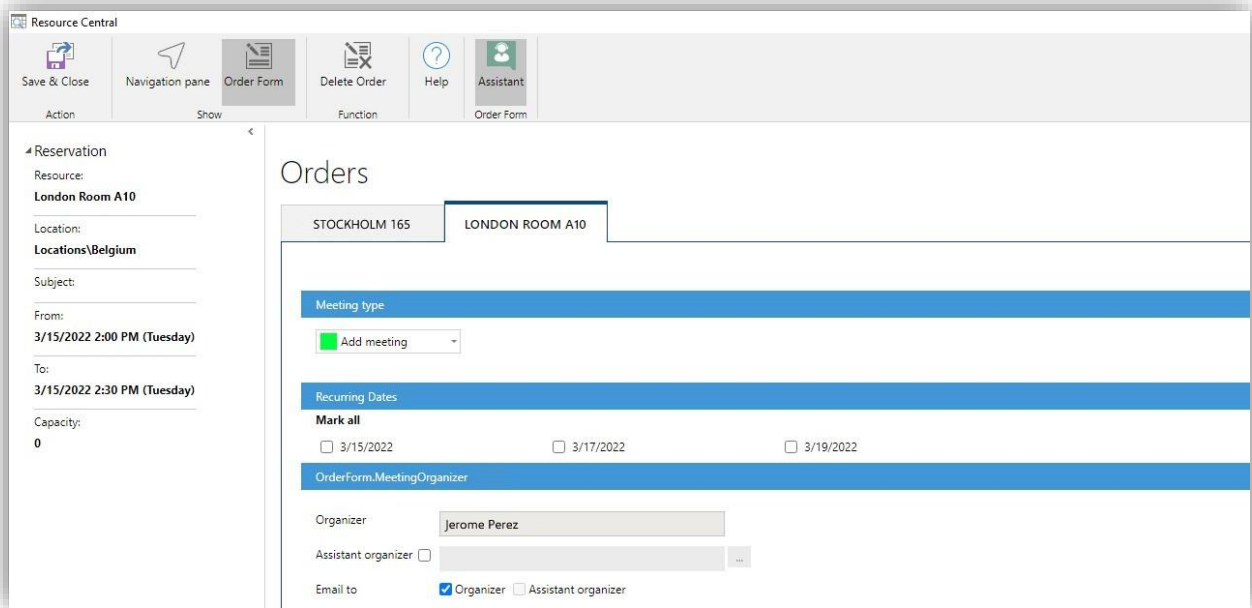
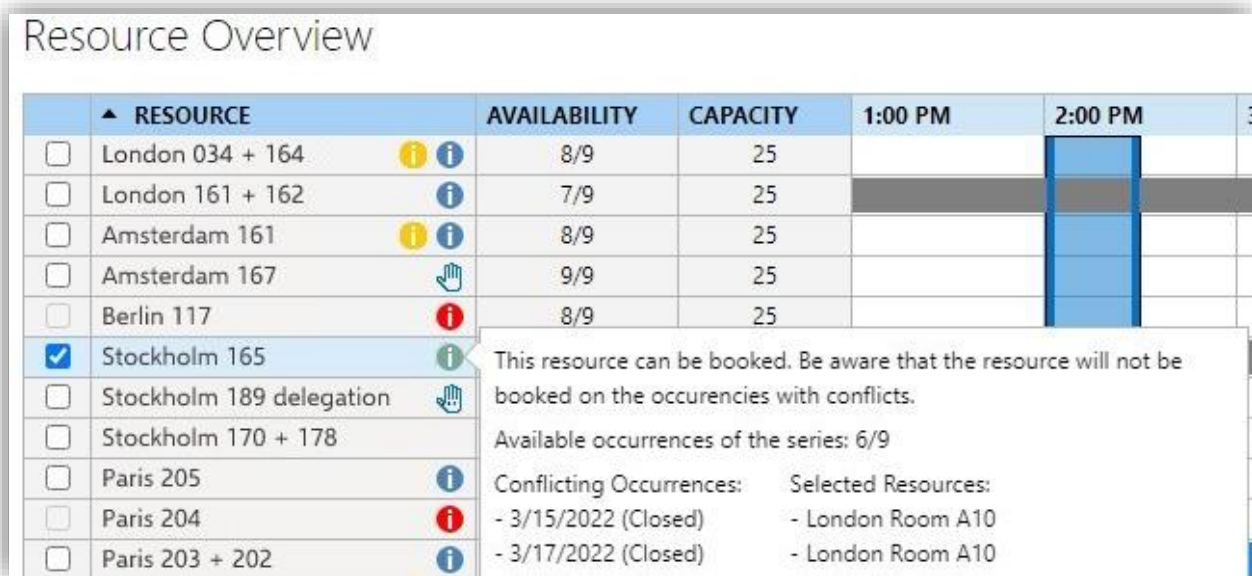

Figure 61. Order services for each selected resource

To understand how to make an order, please refer to [Order form](#).

5. Click on [**Navigation pane**] on toolbar to get back to ResourceFinder's resource list. You will see **i** next to the selected resource:



Hovering on the icon will still show the conflict occurrences, but you will see the alternative resources on Selected Resources row.

Click [**Save & close**] on toolbar to finish. Then on Outlook interface, click [**Send**] to book the meeting.

NOTE: If you want to change alternative resource for a booked recurring meeting, in step 5 when you finally click [**Save & close**] on ResourceFinder, **do NOT click [Send Update] on the Outlook meeting** because your changes are already saved, and it can potentially cause issues with the already booked resources.

Changing Resource of an existing Appointment

There could be a situation when you have to change the resource of an existing Appointment, i.e., you have booked a resource for a specified timeslot, but you want to change the Resource of that Appointment. For this, you will have to perform the following steps:

1. In the calendar of MS Outlook, double click the existing appointment to open it
2. On the appointment window, click **ResourceFinder** button to go to the ResourceFinder for selecting New Resource. When you click the **ResourceFinder** button, ResourceFinder window will open.
3. Select the New Resource and then click **Save and Close** button to return to the same Appointment window, which will look like as shown below:

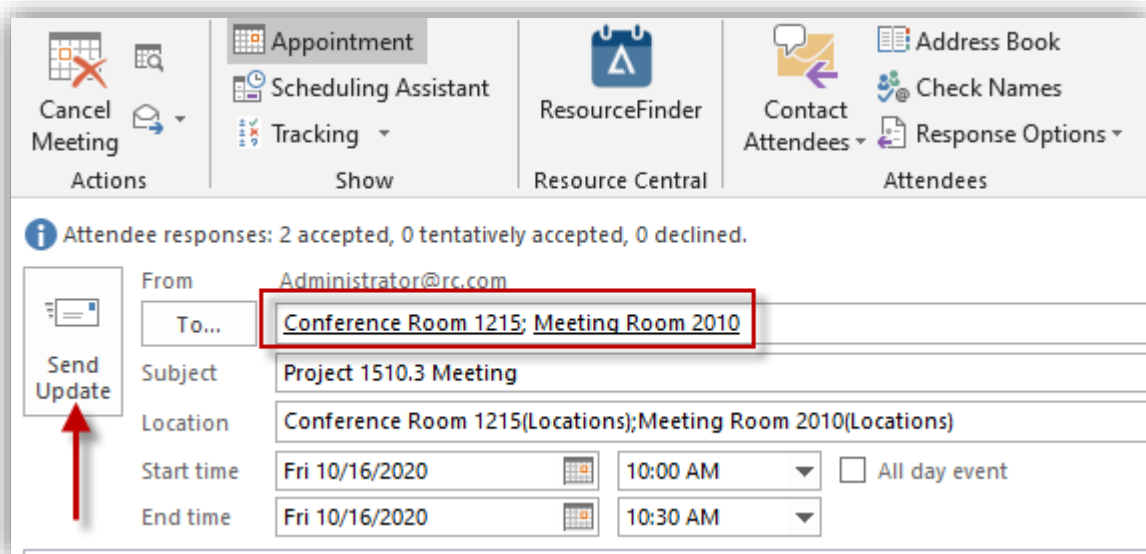

Figure 62. Appointment window with both Previous & New Resource

As you could see in the above figure, that now the Appointment window contains both the Previous Resource & the New Resource.

4. In the Appointment window, manually **REMOVE** the Previous Resource from the “To...” field and then click the **Send Update** button. You will receive a **Cancelled Reservation Email** for the Previous Resource followed by a **New Reservation Email** for the New Resource.

Temporary Booking

ResourceFinder provides a temporary booking function that allows user to save the current reservation while he/she is still editing information on that reservation. This informs others, that a reservation has already been made on a resource at a particular time, so that they cannot make the same reservation.

After user selects a resource and click [**Save and Close**], a temporary reservation will be booked based on the information which the user has made on the current reservation. This reservation will be saved into database and user can see it in reservation overview screen of **Resource Admin** and **ResourceFinder**.

This temporary reservation will be kept for a time that can be set by the parameter **ResourceFinder.PriorBookingTime**. After that time, if the user does not click **Send** button, the temporary reservation will be deleted from database. Otherwise, a reservation will be made as normal.

My Meetings in COM Add-in

My Meetings function provides the user with an overview and access to all booked meetings and associated services - directly from Outlook and Microsoft Teams.

Language of My Meetings

My Meetings will run in the same language as saved in the **Set Default Language** window at the ResourceFinder. In this case, the language of Resource Central Web application and MS Outlook would be ignored.

My Meetings Window

If you have the **Resource Central Add-in** installed, a new button [**My Meetings**] will appear in the toolbar of MS Outlook window (as shown below).

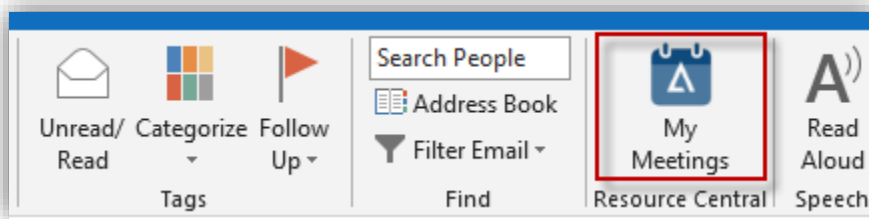

Figure 63. My Meetings button in MS Outlook

Clicking **My Meetings** button will bring up a new screen which will show all meetings made by the user on the selected date. All meetings where you are the Assistant organizer will be listed in a separate section filtered by the email address and name of the organizer that you are assisting.

Navigation Pane

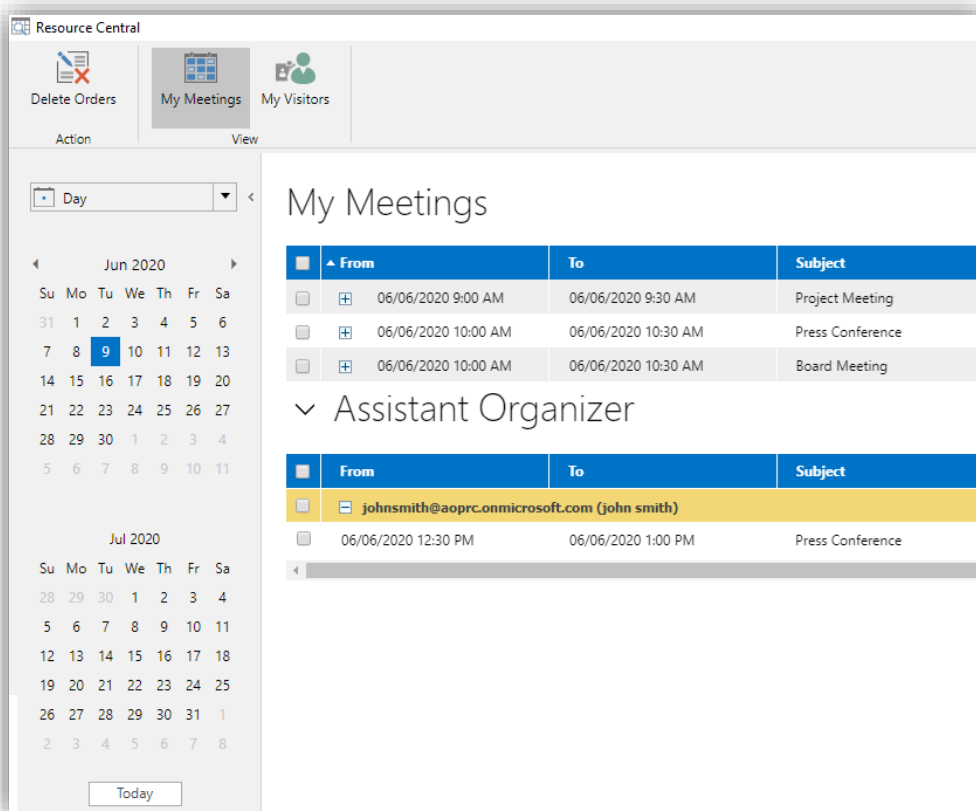

Figure 64. Navigation Pane of My Meetings window

The Navigation Pane of My Meeting window contains the calendar and the periodic view options with which you can select the suitable view for your preferences. By clicking and dragging, you can also select a custom range of the dates that you want.

NOTE: These periodic view options can be seen at **My Meetings, Daily Tasks/Orders** and **Reservations**.

Whenever you click **Today** button, the system will take you back to the current system date and the corresponding summary screen would also be updated accordingly.

Moreover, if you click upon the Month and Year Name then the Navigation Pane will show a list containing the names of all the months to quickly select a month (click on the month name) or a year (use the arrow on the left and the right of the year name).

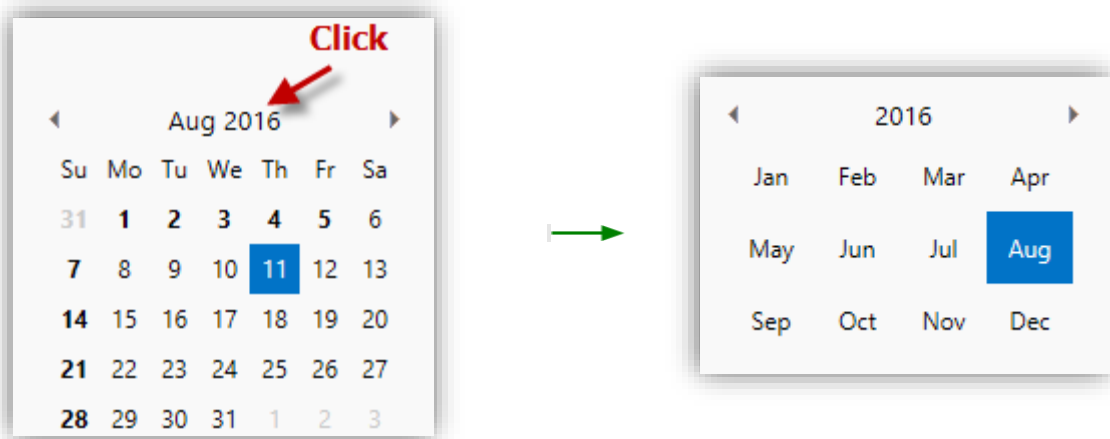

Figure 65. Select Month and Year in the Navigation Pane of My Meetings window

Dates which have at least one reservation will be **bold**. The selected date will be marked blue color.

Meeting List

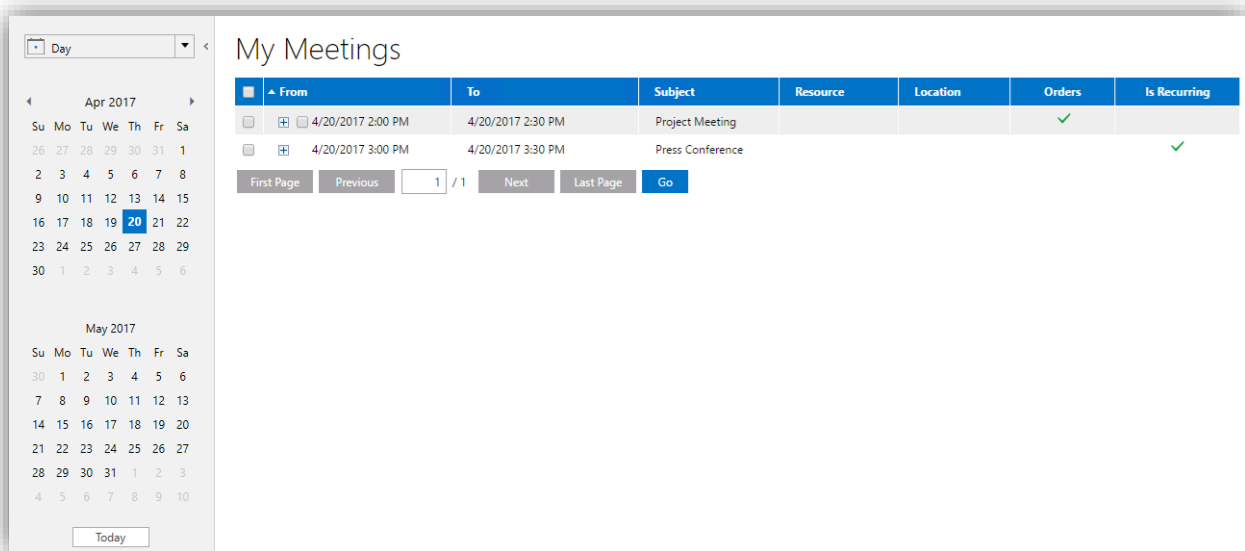

Figure 66. My Meetings screen view

A **check symbol** ✓ is shown against a meeting with an order and/or to show that a meeting is Recurring or not, in My Meetings window.

Location column in the summary screen is associated when the user has placed a reservation over a Light Resource. For detailed information regarding this, please refer to the [Appendix - Location handling when booking resources](#) in this document.

My Meetings Functionalities

Deleting Order associated with Meeting(s)

You can delete one or more order(s) associated with meetings in **My Meetings** window by selecting the checkbox against one or more meetings and clicking the **Delete Orders** button.

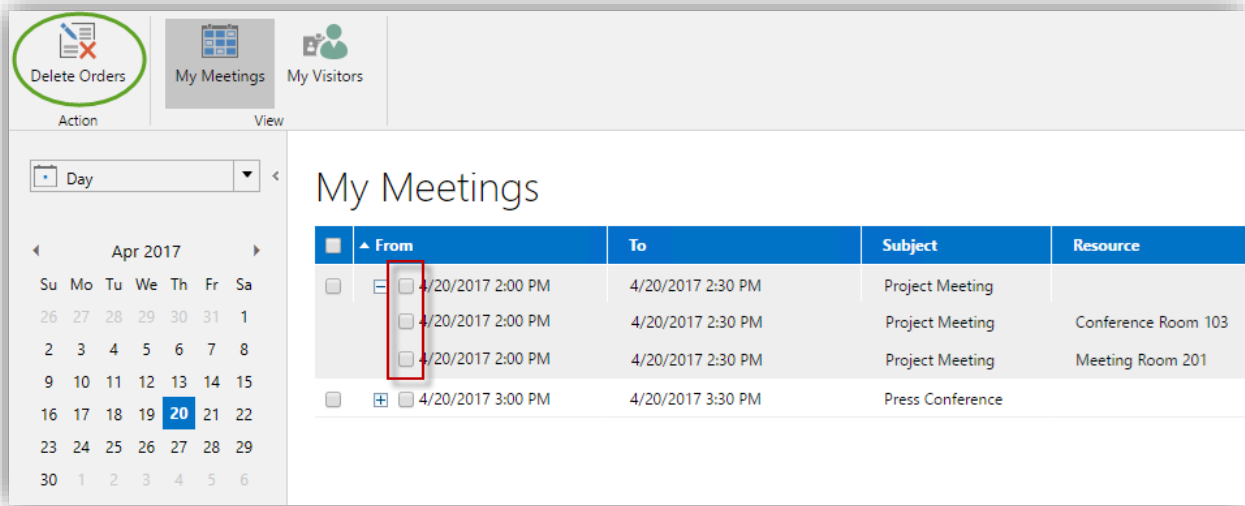

Figure 67. Delete Orders Button

Cancelled Order Email will be sent to the meeting organizer and all persons related to the order. Also, the Check symbol (✓) against that reservation for the **Order** column would also be removed.

NOTE: Those Servings in the order of a reservation in which any of the Item(s) has status = Arranged and/or Locked, will not be deleted from the system. Only those Serving(s) in which the Item(s) have status = New, Changed, Confirmed or Declined, would be removed from the selected meeting(s) and corresponding Cancelled Order emails would be sent to the relevant stakeholders.

Managing Visitors

You can manage all visitors in My Meetings by clicking [**My Visitors**] button, which will open the visitors list in the selected date:

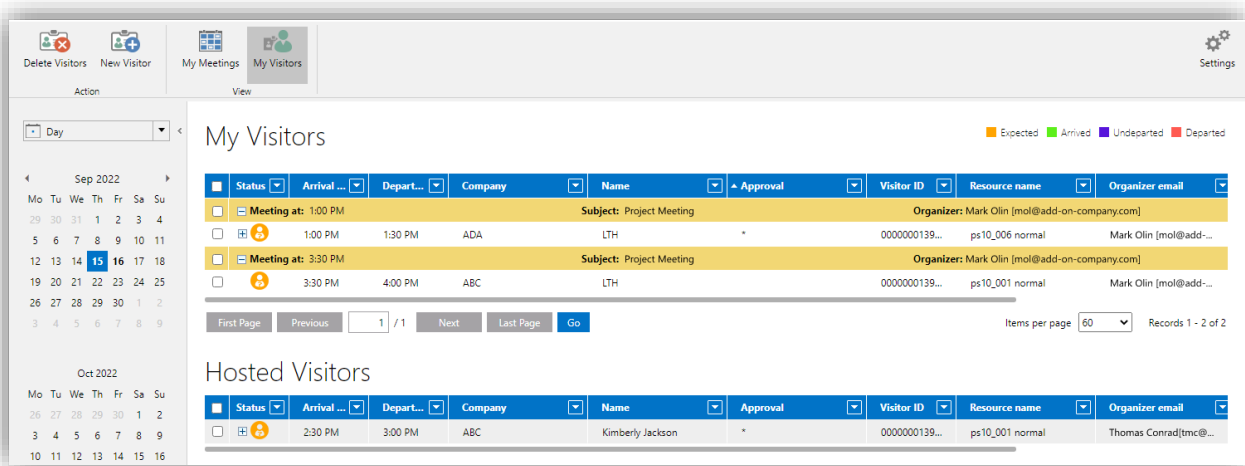

Figure 68. My Meetings – Visitors list

Button	Description
New Visitor	Add a visitor to a meeting or a person/user
Delete Visitor	Delete the selected visitor(s)
My Meetings	Go back to My Meetings list

'My Visitors' list shows all visitors invited to your reservations.

If you are also a Host, you will be a contact person and take care of your visitors during their visit. Those visitors will be shown in 'Hosted Visitors' list.

Clicking on **[New Visitor]** enables you to add a new visitor to a meeting or a person:

Figure 69. Add a visitor to a meeting/person

This process is similar to how you do it via ResourceFinder order form.

You can also set recurring visit for your visitor if the Arrival Date and Departure Date are 2 different dates. In this case, a new option **[Make Recurring]** will appear, e.g.:

Clicking **[Make Recurring]** will open a 'Recurring visit' similar as follows where you can select the exact recurring dates:

Resource Central

Recurring visit

Max number of occurrences: 3

<input type="checkbox"/>	Date		Arrival	Departure
<input type="checkbox"/>	11/11/2022 Friday		8:30 AM	8:30 AM
<input type="checkbox"/>	11/12/2022 Saturday		8:30 AM	8:30 AM
<input type="checkbox"/>	11/13/2022 Sunday		8:30 AM	8:30 AM

Cancel **Save**

Here you can select the exact date and time for each occurrence. Note that there may be a maximum number of occurrences which is determined in **Resource Central Admin → Designer → Visitors** (refer to [Recurring Dates](#) for more details).

After filling in necessary information of your visitor(s), click [**Save**] to finish.

Order Details

You can view order details by clicking on an order in My Meetings window. Calendar date will be shown in **bold** when it contains at least one meeting in My Meetings window.

Toolbar buttons	Description
Order Form	Shows the order form (if any) related to a meeting
Order Status	Shows the status of order items related to an order form of the meeting.
Update	This button will only be displayed at the details of such recurring reservations that have been created with No End Date

NOTE: In My Meetings, organizer can view details of a meeting taking place in the past:

- With normal flow of My Meetings, details of a meeting can be viewed but their details cannot be edited.
- With Shared Order, details of a meeting can be viewed, and their details can be edited.

Order Form

Reservation

Resource: **ps10_001 normal**

Location: **Locations\US\New York**

Subject: **Project Meeting**

From: **9/15/2022 3:30 PM (Thursday)**

To: **9/15/2022 4:00 PM (Thursday)**

Capacity: **10**

Order - 2401

PS10_001 NORMAL Order

If you require extra services for your resource booking, please enter the number of deliveries, and fill out this form.

Number of deliveries:

1st service: [10:30 AM] Delivery time at resource's local time

Comments:

Serving 1

Name	Price	Qty
Cocacola	10.00	<input type="text" value="1"/>
Fish	10.00	<input type="text"/>
item1	10.00	<input type="text"/>
item2	10.00	<input type="text"/>
item3	10.00	<input type="text"/>
item4	10.00	<input type="text"/>
Menu 3	256.00	<input type="text"/>
Vegetable	10.00	<input type="text"/>

Catering Total:

Visitors

Register visitors

Visit detail

Invitee (Organizer): Host: Zones:

Figure 70. Viewing Meeting Details – Order Form

ORDER FORM

Shared Order - 1449

ORDER DETAILS

Region

Your Service Desk Region is Region1

Meeting Rooms

Conference Room 103 (conference103@psmax.com)
 Meeting Room 201 (meeting201@psmax.com)

Comment

SHARED ORDER FORM 07

Host Name

Figure 71. View Meeting Details – Shared Order

For more information about Order Form, its functionalities and workflow, refer to the [Ordering additional services](#) section in this guide.

Order Status

User can view order items status by clicking “**Order Status**” button in Reservation details.

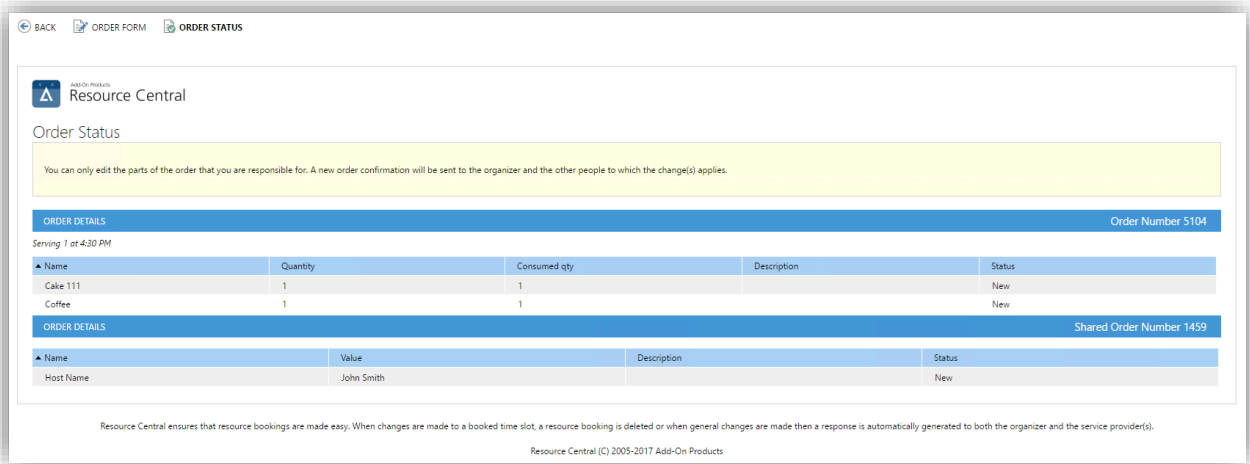

Figure 72. Viewing Order Items status in My Meetings

For booking with shared order, the Shared Order section is always placed at the bottom of the Order Status screen view, under other standard order.

My Meetings Stand Alone Page

Instead of using the My Meetings from the Outlook, if an outside user wants to have a glimpse of the information being displayed in the My Meetings, then Resource Central enables him/her to do so by providing a Stand Alone page for the My Meetings. This would enable the user to view the meetings, along with their orders, without actually requiring logging in the Resource Central system.

For more information in this regard, please refer to the section “**My Meetings Stand Alone Page**” in Chapter 7 → Appendix in this document.

My Meetings in Microsoft Teams

This section describes the feature that integrates Resource Central with Microsoft Teams. With this feature, Microsoft Teams users are able to see all their team meetings with orders in My Meetings, so that they can make or change existing orders for a team meeting.

NOTE: Teams meetings can only be seen in Microsoft Teams. They will not show up on Microsoft Outlook.

How to open the app in Microsoft Teams

After installation (described in **Microsoft Teams Integration Guide**), when you open Microsoft Teams and click the [...] button on the left menu, you can see **Resource Central** in the list of apps:

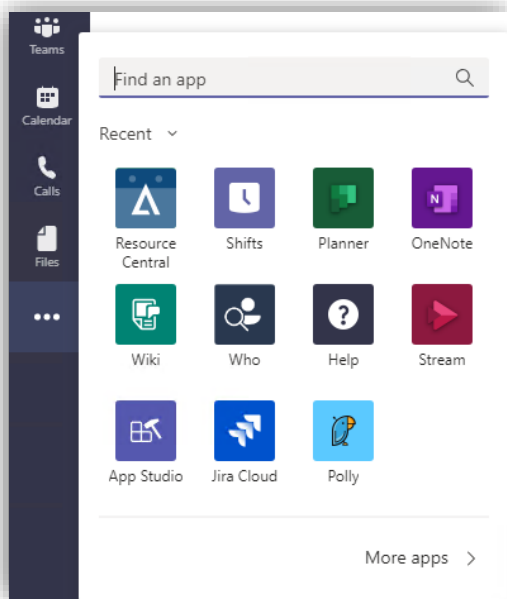

Figure 73. Apps in Teams

Click on **Resource Central** app icon and you can go to **My Meetings** interface.

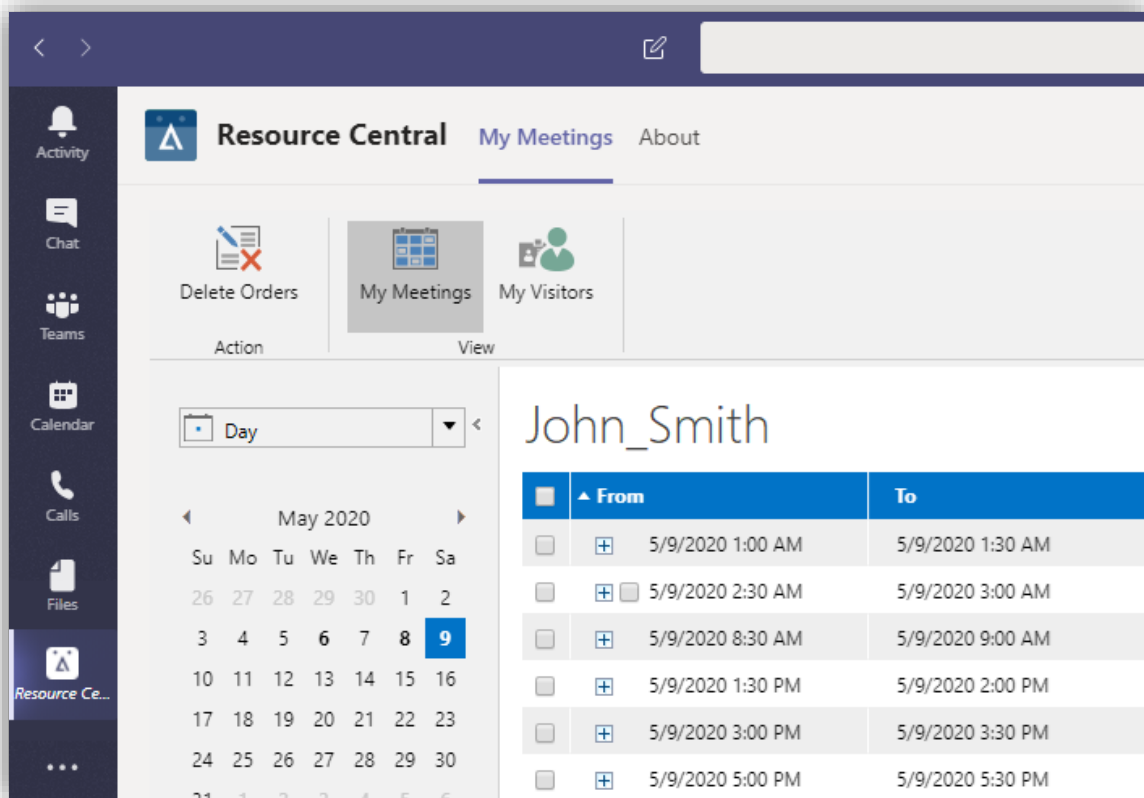
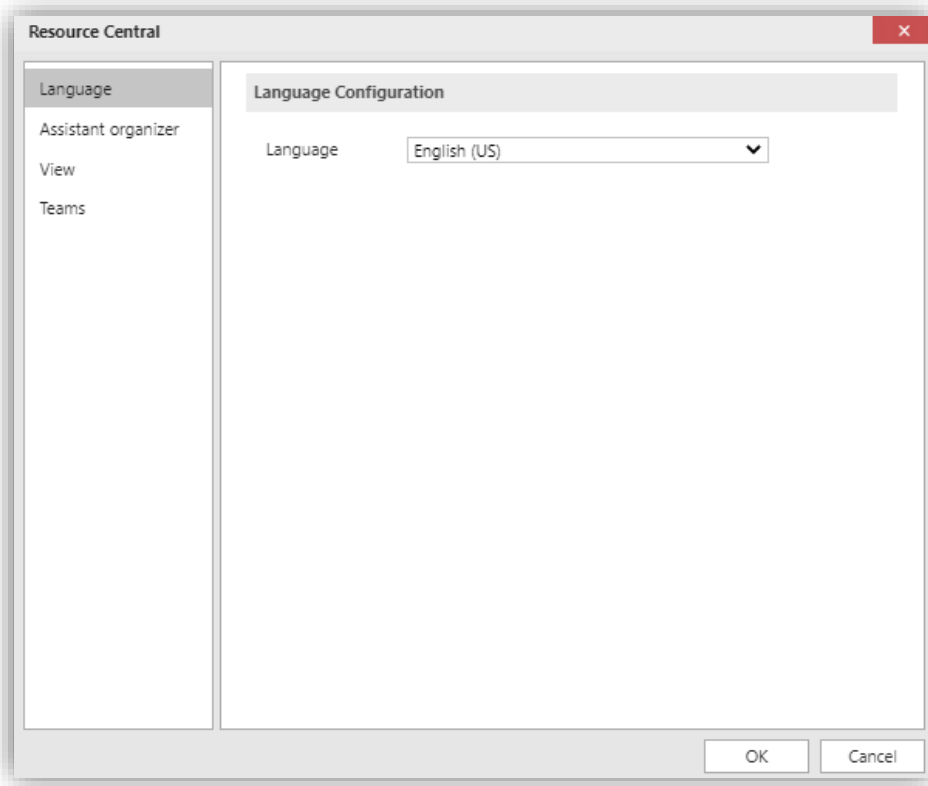

Figure 74. My Meetings in Teams

Now you can perform actions similar to those with My Meetings in Outlook.

Settings for My Meetings in Microsoft Teams

In My Meetings screen in Microsoft Teams, click [**Settings**] button at the upper right corner of the screen, the following dialog shows up:



Tab	Description
Language	Select language to be used for My Meetings in Microsoft Teams
Assistant organizer	Enable Assistant organizer function and select one. <div data-bbox="552 1312 1066 1653" style="border: 1px solid gray; padding: 5px; margin: 10px 0;"> <p>Assistant Organizer Configuration</p> <p>Assistant organizer</p> <p><input checked="" type="radio"/> Enabled <input type="radio"/> Disabled</p> <p>Default Assistant</p> <p>aoprc_sp@aoprc.onmicrosoft.com</p> <p>Email flow</p> <p>Primary AND assistant organizer</p> <p><i>Note: An Assistant Organizer can receive the same emails from Resource Central as the organizer and can handle orders on behalf of the organizer.</i></p> </div>
View	Select if you want available resources are displayed <div data-bbox="552 1760 1066 1944" style="border: 1px solid gray; padding: 5px; margin: 10px 0;"> <p>Language</p> <p>Assistant organizer</p> <p>View</p> <p>Teams</p> <p>View Configuration</p> <p>Display Available Resources as default</p> <p><input type="radio"/> Enabled <input checked="" type="radio"/> Disabled</p> </div>
Teams	Enable or disable teams shown in My Meetings in Microsoft Teams

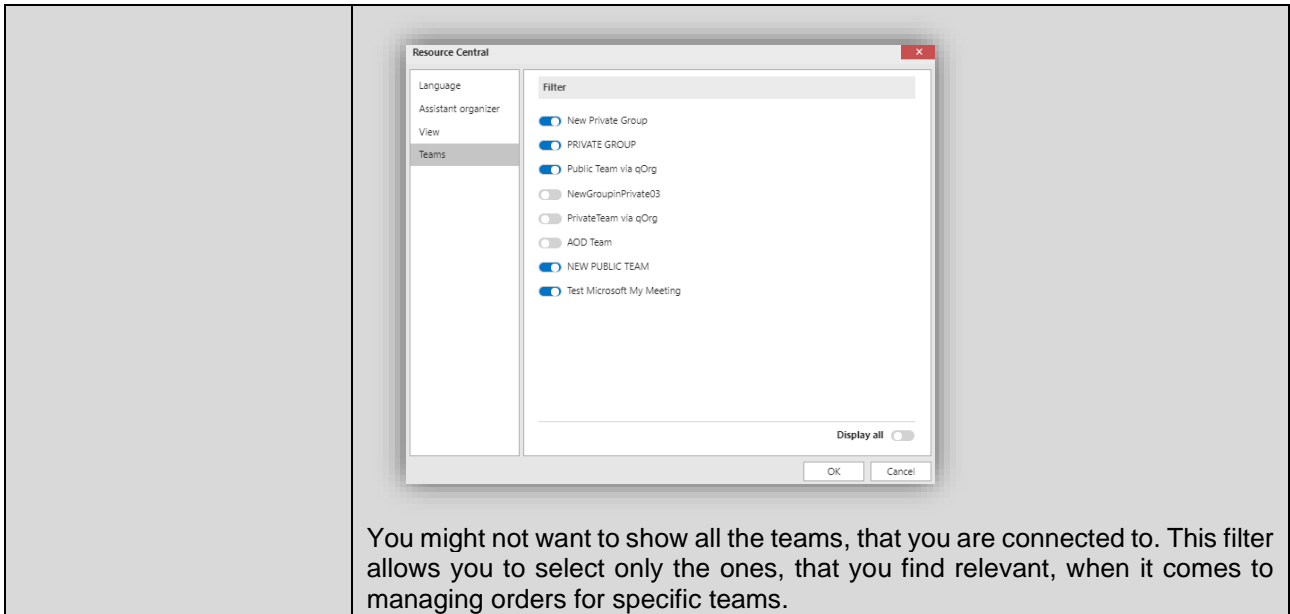

How Assistant Organizer can use My Meetings in Microsoft Teams

When you book a Teams meeting in a channel, the meeting organizer will be the team (that the added channel belongs to). Therefore, all notification emails are sent to this Teams meeting organizer. If you want to get reservation and order emails for these Teams' meetings, it is important and needed, that you add yourself as an assistant organizer for the meetings, that you are responsible for. Find your Team meetings in the Teams section of the My Meeting application.

No one from the team will receive email notification, but members of the team can see the meeting when they open My Meetings app in Teams.

As an assistant organizer of a meeting, when you select a date on the calendar, all meetings on that date will be displayed on the right side of the panel.

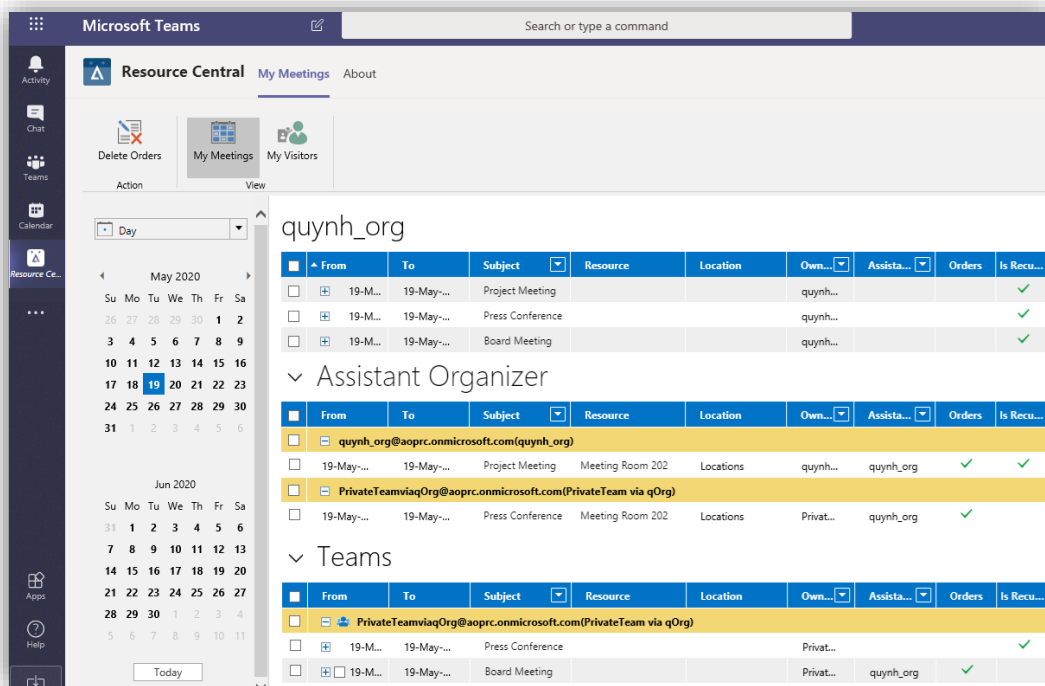

Figure 75. My Meetings in Teams

The first section (with your name as the heading) shows all meetings where you are organizer.

The **Assistant Organizer** section shows all meetings where your role is Assistant Organizer.

The **Teams** section shows all meetings booked via Microsoft Teams.

NOTE: Only teams enabled in **Settings**→ **Teams** and have booking data are displayed in **Teams** section.

Ordering additional services

RESOURCE CENTRAL is seamlessly integrated with MS Exchange. Whenever you create a meeting, and you use the resource facility in Outlook, **RESOURCE CENTRAL** will **keep an eye** on that.

When you have made a reservation of a meeting room, an e-mail will be sent to you. The e-mail contains a link to an order form to order individualized catering and other services.

Resource Central

New Reservation - Order Number 2401

The resource **ps10_001 normal** has been reserved on the following date by **Mark Olin [mol@add-on-company.com]**

From : **September/15/2022 10:30 (Thursday)**
 To : **September/15/2022 11:00 (Thursday)**
 Subject : **Project Meeting**

If you want to change something in the order then please [Click here](#)

Details

Orders

Serving 1 at 10:30

Name	Qty	Consumed qty	Price	Total	Status	Description
Cocacola	1		10.00	10.00	New	
Catering Total:				10.00		

Visitors

Title	Name	Company	Email	Cell. / mobile number	Category	Visitor Type	Wifi access	Address	City	Reason for visit	Comment
CEO	LTH	ABC	lth@psaod.onmicrosoft.com	123123213123		Meeting participant	Yes			Business	

Figure 76. New Reservation Email

Clicking the **Click here** link will open order form in a new browser window (as example below):

Reservation of ps10_001 normal

From: September/12/2022 10:30 (Thursday) Subject: Project Meeting

To: September/12/2022 11:00 (Thursday) Description: Romance Standard Time

Location: Locations\US\New York Capacity: 10

PS10_001 NORMAL Order

If you require one or more servings for your resource booking, please enter the number of deliveries, and fill out this form.

Number of deliveries: 1 Delivery

Serving 1: 10:30 +

Comments:

Serving 1 Number of persons: 20 (Min. 5)

Name	Price	Qty	Quota
Coke	10.00	<input type="checkbox"/>	999999970
Tea	10.00	<input type="checkbox"/>	999999983
Lunch menu	12.00	<input type="checkbox"/>	
Dinner menu	10.00	<input type="checkbox"/>	
Coffee	200.00	<input checked="" type="checkbox"/> 20	1078
Beer	20.00	<input type="checkbox"/>	88
Wine	20.00	<input type="checkbox"/>	1234
Herbal tea	50.00	<input type="checkbox"/>	1234
Macaroncookies 1	0.00	<input type="checkbox"/>	1224

Send order

Figure 77. Example of Order Form opened from the links in email sent to organizer

Shared Order Form

RESERVATION DETAILS

Subject: Press Conference

From: 20 April 2017 12:30 (Thursday)

To: 20 April 2017 13:00 (Thursday)

ORDER DETAILS

Region: Your Region cannot be determined - please specify: Region1

Meeting Rooms: Board Room 202 (room2@psmax.com)

Comment:

SHARED ORDER FORM 07

Host Name:

Send order

Figure 78. Example of Shared Order Form opened from the links in email sent to organizer

Order form

NOTE: If you are viewing the **Order Form** from any of the Emails and/or My Meetings section, it will always be displayed in the same language that has been selected in the Language dropdown list at **ResourceFinder**.

The **RESOURCE CENTRAL** order form is divided into five sections, each section is represented by its respective head which can be expanded or collapsed to show or hide the section details.

Section details can be shown by clicking on (+) sign at right side of the heading whereas the section details can be hidden by clicking on (-) sign at right side of the heading.

All sections of the form can be expanded by clicking on **Expand All** link at top of the order form as shown below:

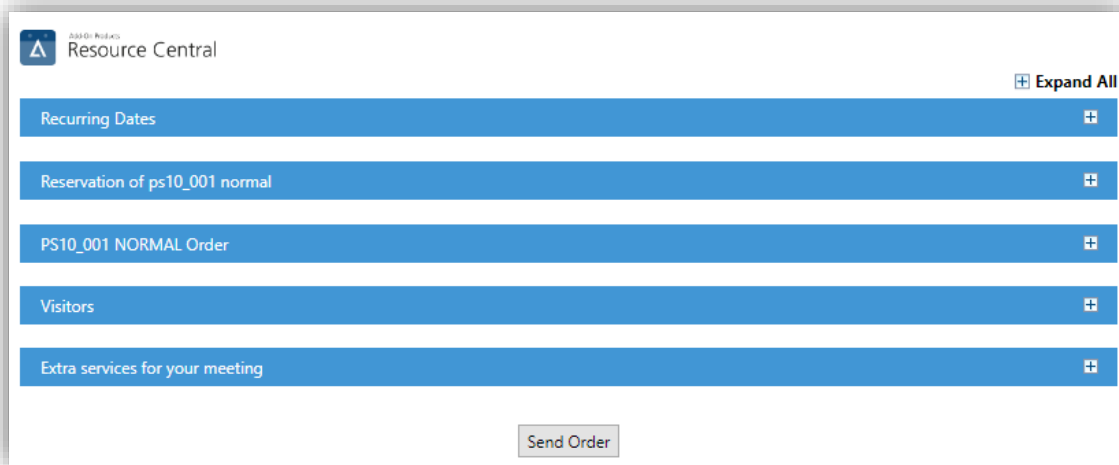

Figure 79. Order Form collapsed

All sections of the form can be collapsed by clicking on **Collapse All** link at top of the order form as shown below:

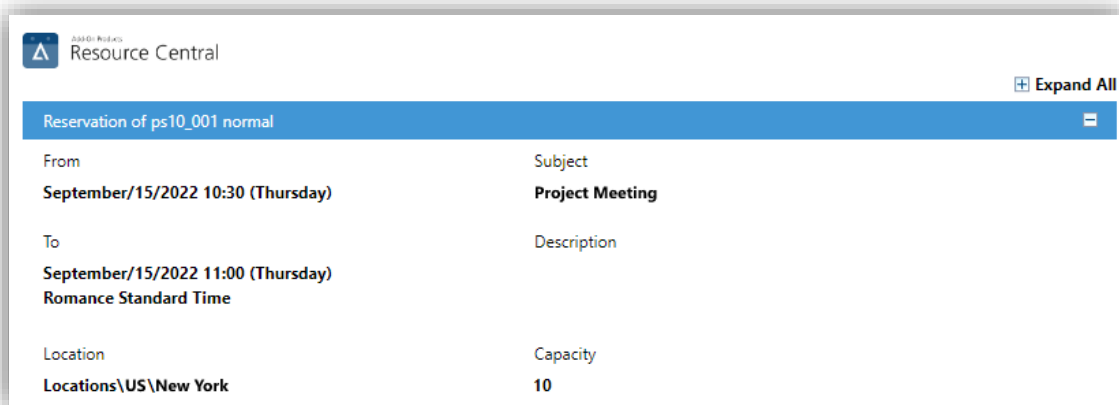

Figure 80. Order Form Expanded

NOTE: Properties that have 'Locked = Yes' in their Property Details will appear as Disabled in the PROPERTIES section.

The heads in the order form are:

1. Recurring Dates (if you create recurring reservation)
2. Reservation details (or 'Reservation of [Resource Name]')
3. Order details (or '[Resource Name] Order')
4. Visitors
5. Properties (or Extra services for your meeting)

Order Details, Attendees and Properties headings are not shown in order form in the following cases:

Condition	Impact on Order Form
Maximum number of Services	Order Details section will not be shown in the order form if 'Maximum number of services' field has 0 value in Resource Details
No Recurring Reservation	If the reservation has not been created as a Recurring Reservation, the Recurring Dates section would not be shown on the Order Form.
Ask for attendees in order form	'Attendees' heading is not shown in the order form if Ask for attendees in order form has No value in Resource Details.
No properties are associated in the Order Form related to the resource	Properties heading is not shown in the order form

Resource detail

This part of the order form is used to display the details of a resource and reservation timings.

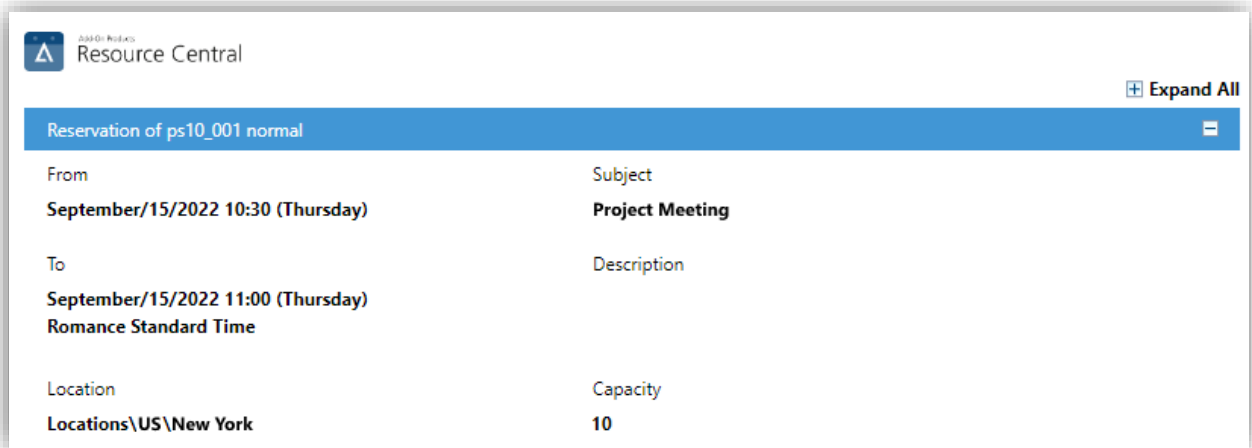

Figure 81. Resource detail part in Order form

Field	Description
From	Reservation Start date and time
To	Reservation End date and time
Description	A short description of the resource as given in resource details
Location	The location of the resource as selected in resource details
Capacity	Capacity of the resource as given in resource details
Minimum Hours	Minimum hours – deadline date as given in resource details.

Recurring Dates

This part is only available at the Order Form if the reservation has been created as a Recurring Reservation. Moreover, this section will only be shown on the Order Form as long as the order has not been placed. Once you have submitted the order by clicking the **Send Order** button, this section will no longer be accessible to you by any means on the Order Form. After placing an order through this order form, you can place/update order through My Meeting section for independent reservations.

Figure 82. Recurring Dates section in Order form

This section shows the list of all the dates on which the Recurrence for a reservation has been made.

All the dates listed are accompanied by check boxes.

If you want to associate an order with some/all of the recurring reservations, you will have to check the respective checkboxes, so that the order (serving, attendees and/or properties) selected on this form will also be associated with all the checked dates in the Recurring Dates section by clicking “**Send Order**” button. After this, you will receive New Order Emails corresponding to all of the checked dates.

NOTE:

- If any of the dates listed in the Recurring Dates section has been defined as a Holiday in the associated calendar of its respective resource, then that particular date(s) will be disabled, so that you cannot place any order over that date.
- If the maximum number of recurring visits is specified in **Resource Central Admin → Designer → Visitors**, that number will be displayed in this part (see example figure above). This means organizers can only mark up to that maximum number of dates. If they mark more dates than the specified number, the following message will be shown:

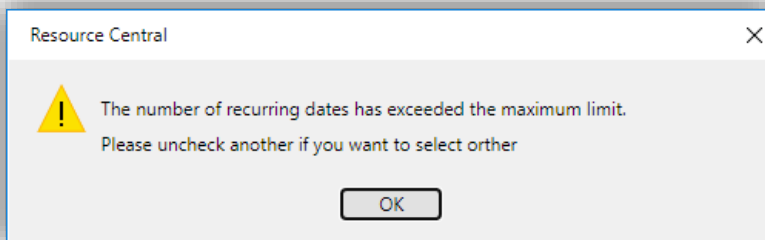

As specified before, you can only access this section on the Order Form as long as the order has not been placed. If you try to access this section from the same New Recurring Reservation Email Link after placing an order, an appropriate message will show up as shown below:

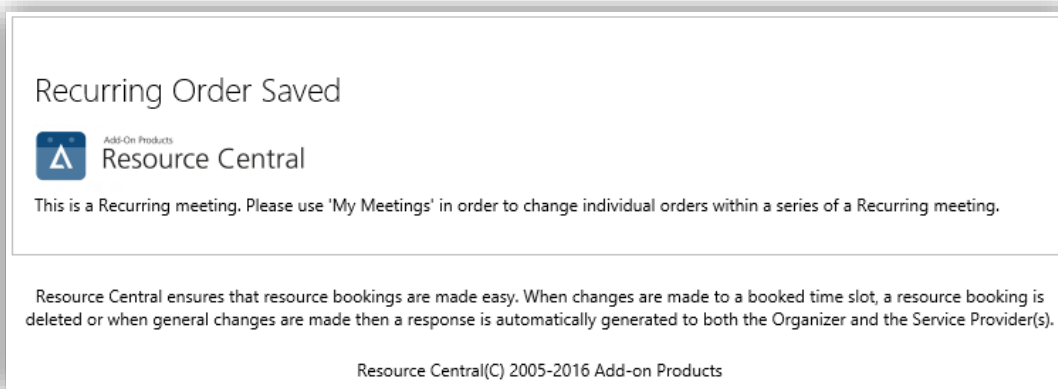

Figure 83. Message displayed when accessing the Recurring Dates section from New Reservation Email

If you have checked only some of the dates in the Recurring Dates section, and now you want to place order against the remaining reservations, you will have to do that manually by navigating through the details of each reservation in My Meetings.

Order details

This part contains a menu list for each of the services requested. It can be used to control the number of services requested. You can also select when the respective service is required from the time value combo box against each service:

Figure 84. Order detail part of Order form with Servings in classic format = Yes

Fields	Descriptions
Number of deliveries	No of services in the order, by default a new resource has 1 Service value and maximum of 9 Services can be selected (as defined in resource details in Resource Central Administration page). Clicking + will also add a new serving, while clicking 🗑️ will remove a particular serving.
Name	Name of the item
Price	Sales price of the item as given in item details in Resource Central Admin Interface Decimal value up to 2 decimal places will be shown in item price
Qty	Quantity of the item to be ordered
Quota	The available amount of the items

If you are organizing an all-day meeting, you can order breakfast, lunch, and dinner in one single form. By default, **No Delivery** value is selected in **Number of deliveries** combo box. The number of services selected from the combo box with all items associated with the resource will be shown against each service. You can select a maximum of 9 servings in a single order.

You can order the required items by entering their quantity. Items that you don't want to order should be left blank (no value).

Finally, at the bottom of this section, you will find a **'Catering total'** which will show the total cost for all the servings in your order. Items price and Catering Total values are calculated up to **2 decimal places** precision.

This format of the Servings is only applicable if the **'Show servings in classic format? = Yes'** for this resource.

If **'Show servings in classic format? = No'** for this resource, then the servings in the order form will be displayed as drop downs as per the Group Name(s) to which the associated item(s) belong to, as shown below:

MEETING ROOM 002 ORDER

If you require extra services for your resource booking, please enter the number of deliveries, and fill out this form.

Number of deliveries: 1 Delivery

Serving 1: 08:30 AM

Serving 1

Drinks: [Dropdown]

Food: [Dropdown]

Name	Price	Qty
Tea	7	2
Cake	8	2
Catering Total		30.00

Figure 85. Order detail part of Order form with servings in classic format = No

As you can see in the above figure, upon selecting a serving, the drop downs of the Group Name(s) of the Associated Item(s) are displayed. When you select item(s) from the respective drop downs, those items will be appended with the current serving. Against each appended item, an 'X' sign is displayed, clicking which the Item(s) is removed from the serving and is again available in the respective Group drop down.

You can utilize the feature that forces organizer to invite internal/external visitors if he/she wants to order catering by setting up the parameter **OrderForm.ExternalVisitor.EnableCatering**. This feature works in conjunction with parameters **OrderForm.AntiAutoAdded.Domain** (to differ internal attendees and external visitors for the meeting) and **ResourceFinder.ExternalAttendeesSynchronized** (to synchronize attendees' data between to 'To' field in Outlook invitation and Order Form).

Parameter	Descriptions
OrderForm.AntiAutoAdded.Domain	This parameter controls a list of domains so that attendee's emails with these domains will not be automatically added into order form. Value of this parameter is a list of domain names, separated by semi-colon (e.g., add-on.com; aop.com)
ResourceFinder.ExternalAttendeesSynchronized	This parameter controls attendee synchronization between Order Form and Outlook invitation. When the parameter has the value equal to '1': <ul style="list-style-type: none"> - If Organizer adds External Attendees in "To" field of Outlook and opens Order Form, those Attendees will be filled into Attendees of Order Form. And vice versa, if Organizer adds new attendees to Order Form, clicks [Save and Close], new attendees are also filled into "To" field in Outlook. - Removed Attendees in Outlook invitation will not be updated into RF Order Form. NOTE: We only support this in One-Step Ordering.

When the parameter has the value equal to '0' or any value other than '1':

- Added Attendee(s) in RF Order Form will NOT be inserted into Outlook invitation. But added Attendees in Outlook invitation will be inserted into RF Order Form.
- Removed Attendees in RF Order Form will not be updated into outlook invitation.

Default value of this parameter is '0'.

After this feature is enabled, the catering section in Order Form will be locked and it is only available when the organizer fills in the visitor's email address.

NOTE: This feature is not applied to Outlook Add-in.

Visitors

This part of the order form contains a 'Register Visitors' checkbox. By clicking it you have the option of entering visitors' information. These meeting visitors' details will be shown in **Visitors** section to the person (created in the system) having the same location as defined for the resource.

This section will show the visitors added by organizer via the order form, and also also those who are added from the **Resource Central Admin** (refer to **Resource Central Admin** → **Daily Tasks** → **Visitors** section to know how to add visitors via this admin interface).

Figure 86. Register Visitors in Order form

In 'Visit detail' area, you can configure the following fields:

Fields	Descriptions
Invitee (Organizer)	The organizer's name of this reservation.

Host	You can add a person as the reservation's host using his/her email address in your organization domain. The Host will be responsible for taking of the visitors during their visit. If no Host is added, the organizers themselves will become the host.
Zones	Select zone(s) where visitors can travel to. A zone can include multiple locations, which can be set in RC backend → Location → Zones .
Set escorted for all visitors	When checked, you can set 'Escorted' to all visitors below, either Escorted or Unescorted . Also, the Escorted settings from RC backend → Designer → Visitors will be ignored for this reservation. By default, this option is unchecked.

In 'Visitor details' area, you can click **[Add]** to create new visitor. For each visitor, you can edit the following:

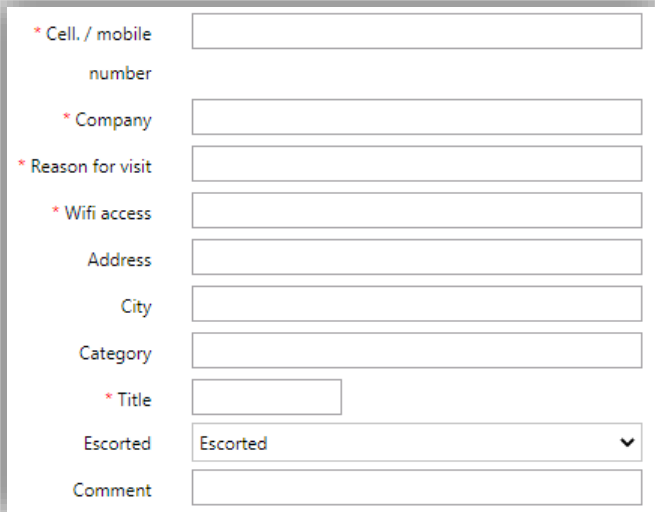
Fields	Descriptions
Email	The email of the visitor.
Name	The name of the visitor.
Visitor Type	Select a visitor type for this visitor,
Remove	Delete this visitor from the list.
Details	<p>Clicking on it will show the Details of the visitor. E.g.:</p>  <p>The shown detail fields are configured in RC backend → Designer → Visitors. In addition, the 2 bottom fields are always available:</p> <ul style="list-style-type: none"> • Escorted: by default, this field will show either 'Escorted' or 'Unescorted' based on the RC backend → Designer → Visitors settings. But you can manually select either status. • Comment: enter a comment for this visitor

In case of recurring reservation, the added visitors will also be invited to all the occurrences. When the reservation is accepted, its organizer will receive emails informing the exact date of each occurrence, as well as the invited visitors in all occurrences.

On **Resource Central Admin**, the invited visitors will be registered on **Daily Tasks → Visitors** section on each occurrence date. The visitor authorizer will then be able to give authorization to each occurrence. For more details on visitor authorizer, refer to [Visitor Authorization](#).

Properties – Resource specific

The last part of the order form is resource specifics and can be customized by your Resource Central administrator. The properties associated with the order form of a resource are all displayed here.

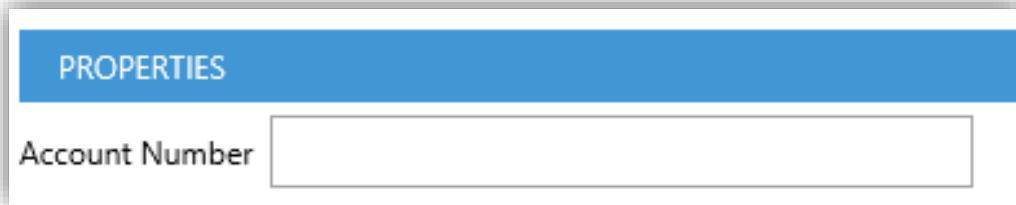

Figure 87. Properties part of Order form

Click [**Save**] button to send the order.

Customizing Order form

“Send order” and “Send reply” buttons placement

The placement of the **“Send order”** & **“Send reply”** buttons at the Organizer and Service Provider’s order forms can be controlled via the advanced parameter **“OrderForm.SendOrderAlignment”**, by the help of which the buttons could be left, center or right aligned in the order form.

For more information regarding this parameter, please refer to **Resource Central Parameter Guide**.

Customizable heads in Order form

The heads shown in the order form are customizable as shown below:



Figure 88. Customizable heads in Order form

For custom form heading, following parameters are required with required custom values as shown below:

Parameters	Functions
OrderForm.ReservationOf	Value given for this parameter will be shown in ' Reservation ' heading in the order form
OrderForm.Recurrence	Value given for this parameter will be shown in ' Recurring Dates ' heading in the order form
OrderForm.OrderHead	Value given for this parameter will be shown in ' Order Details ' heading in the order form
OrderForm.Attendeas	Value given for this parameter will be shown in ' Visitors ' heading in the form.
OrderForm.Properties	Value given for this parameter will be shown in ' Properties ' heading in the order form.

When one of the above parameters is changed, the heading of the respective section in the form is changed accordingly. If the value of the parameter is left blank or the parameter is not defined in Parameters section, then default values of each section heading will be displayed as shown below:

The screenshot shows a form titled "Order". At the top right, there is a link labeled "Expand All". Below this, there are five blue horizontal bars, each representing a section heading with a small expand icon on the right:

- RESERVATION OF MEETING ROOM 002
- RECURRING DATES
- MEETING ROOM 002 ORDER
- ATTENDEES
- PROPERTIES

At the bottom center of the form, there is a button labeled "Send Order".

Figure 89. Default heads in Order form

Sending the order

When you click [**Send order**], the order form will check if all mandatory fields are filled out.

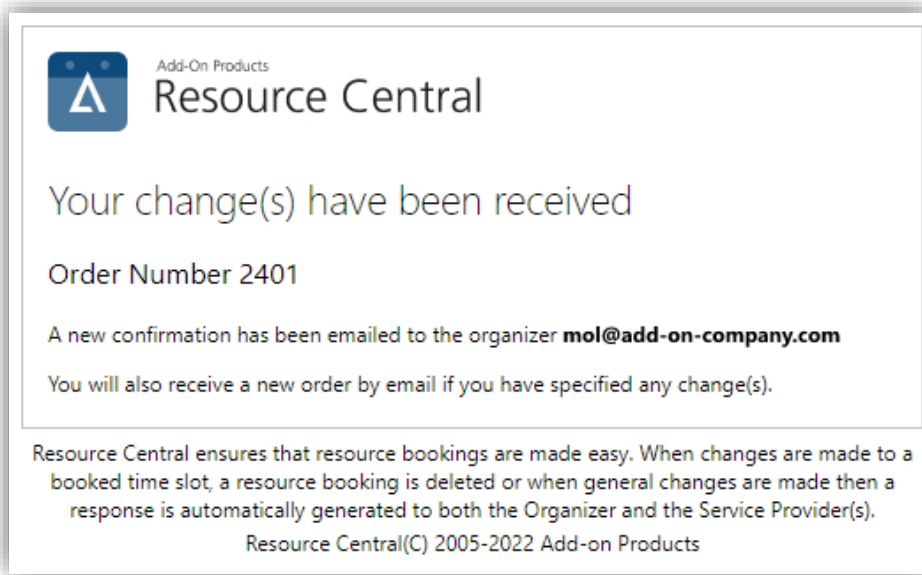

Figure 90. Order form confirmation

When all fields are completed, the order is sent to RC Database, processed by Synchronize Service and emails will be sent to organizers (Order Confirmation Email) and to the nearest located Service Provider related to the order (New Order Email).

Order confirmation

You (as a meeting organizer) will also receive an e-mail confirming the order after submission of the order form. Order confirmation email is also sent to the nearest located Service Provider related to order item or property.

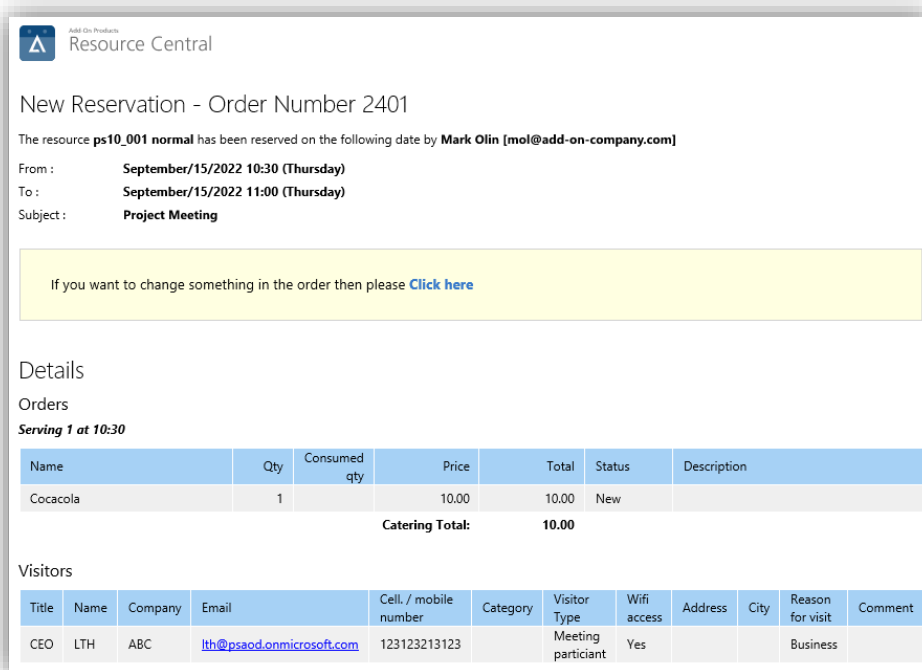

Figure 91. Order Confirmation Email

Changing the order

Organizer can use the link in the order confirmation email to re-open the order form and make any changes in it. Change order email will be sent to the meeting organizer and Service Provider.

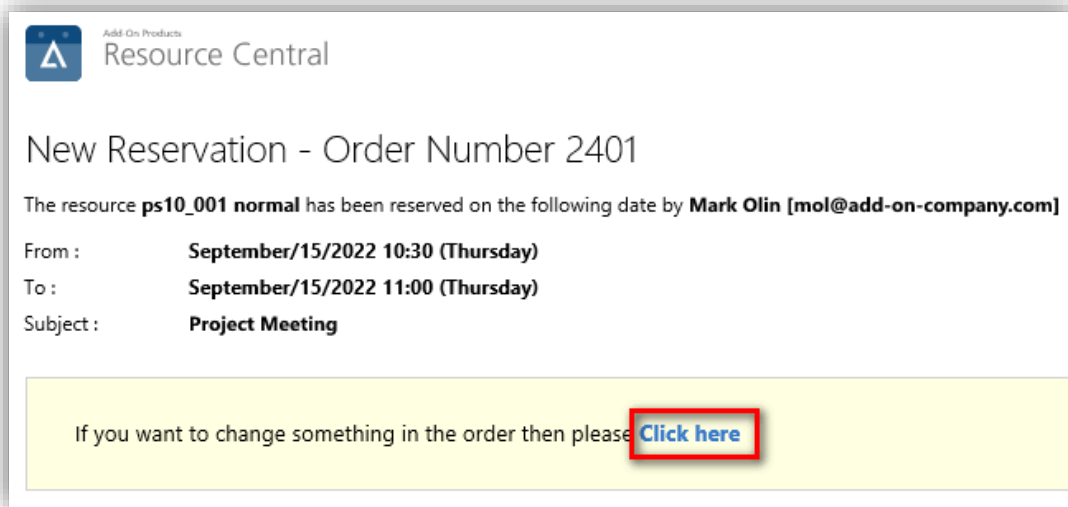

Figure 92. Order Change

If the Service Provider related to the order item changes the status to Changed or changes the quantity of order, change order email is sent to the meeting organizer.

If a property value is changed by Service Provider from his respective order form, change order email is also sent to the meeting organizer.

Cancelling the order

If you cancel or delete your appointment in Outlook or when an order is deleted from **My Meetings** window or delete the appointment from the respective Resource Calendar in MS Outlook, Resource Central will monitor that, and automatically cancel the order and reservation.

A Cancelled Reservation email (if the appointment is deleted in Calendar of Outlook) or Cancelled Order email (in other situations) will be sent to meeting organizer and nearest located Service Provider/roles related to the order.

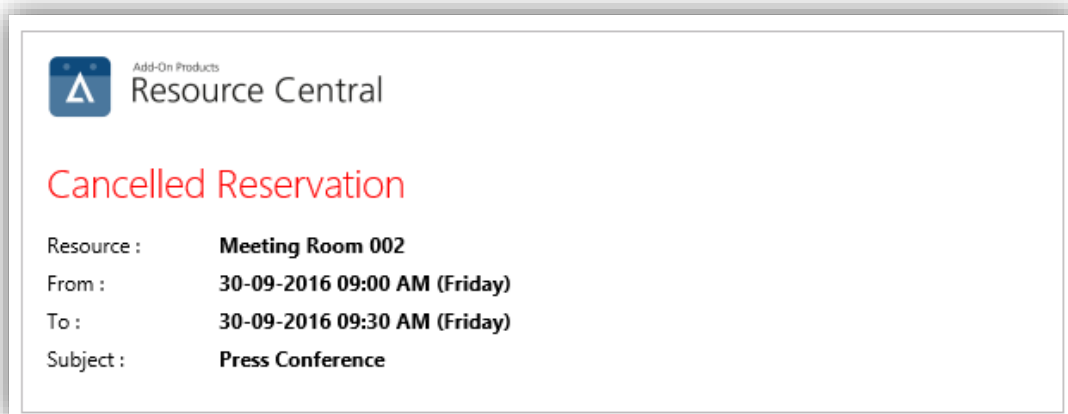

Figure 93. Reservation Cancellation Email

Service Provider handling service orders

Whenever the appointment is changed, or deleted **RESOURCE CENTRAL** will keep track of it and generate e-mails to meeting organizer and Service Providers accordingly.

Also note that once the Service Provider sends a comment over an order, that comment will be displayed in all emails afterwards sent to the Organizer of that reservation and Service Provider of the associated order with that reservation, under the Replies section.

Role Types

There are 2 role types that can be set to each Item & Property assigned to a service provider's role: **Assignable** and **Informative**. These role types can be set in **Security** → **Roles** (refer to [Roles / Items](#) and [Roles / Properties](#)).

'Assignable' role type

A service provider can only handle Items & Properties that have 'Assignable' type related to his/her Role. Also, in an order that affects multiple service providers, each of them can only handle the Order status of Items & Properties that are 'Assignable' to their Role.

(Refers to [Order status calculation](#) to understand how the Order status is determined)

NOTE: To be able to set status for Properties, their 'Use status' setting must be 'Yes' (refer to **Designer** → **Properties** for more details).

'Informative' role type

If service provider has Items & Properties with 'Informative' type related to his/her Role, it means that service provider can only see those Items & Properties but are NOT allowed to handle them.

Also, the 'Informative' items & properties will not affect the Order status shown for individual service provider.

Addition of Item(s) and Properties by Service Provider

In Resource Central, after clicking **[Click Here]** in email sent to Service Provider or accessing RC Admin Interface, the Service Provider can add more items and/or properties to serving(s). For this, an expand button named **[Add]** is provided under each Serving in both "Order Details" and "Properties" (if any) sections:

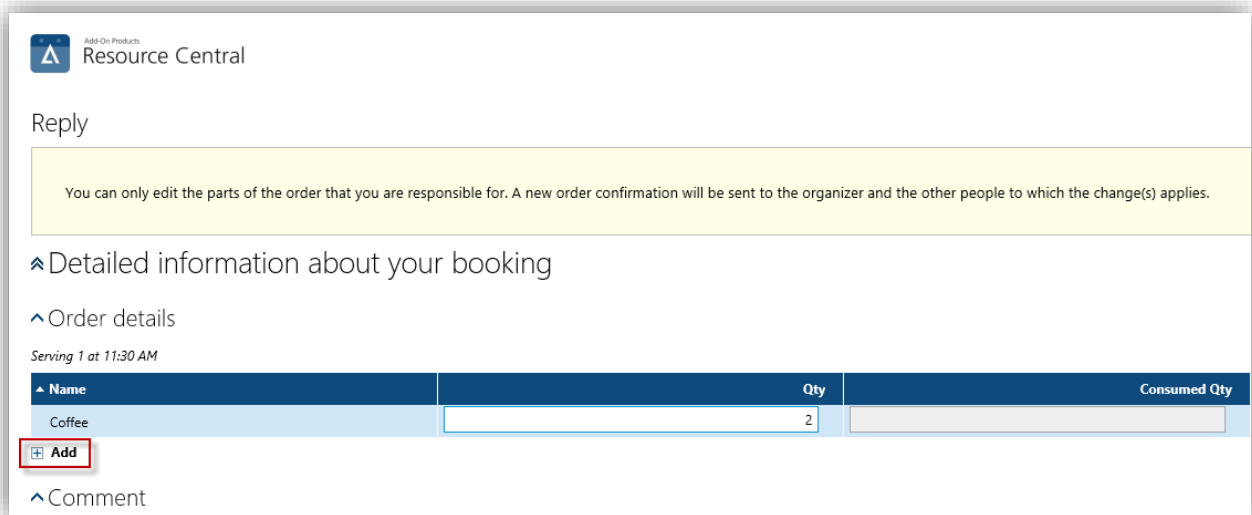

Figure 94. Order form of the Service Provider with Add Link

When the user clicks the **[Add]** button, the remaining Items (and Properties) of that serving are displayed, as shown below:

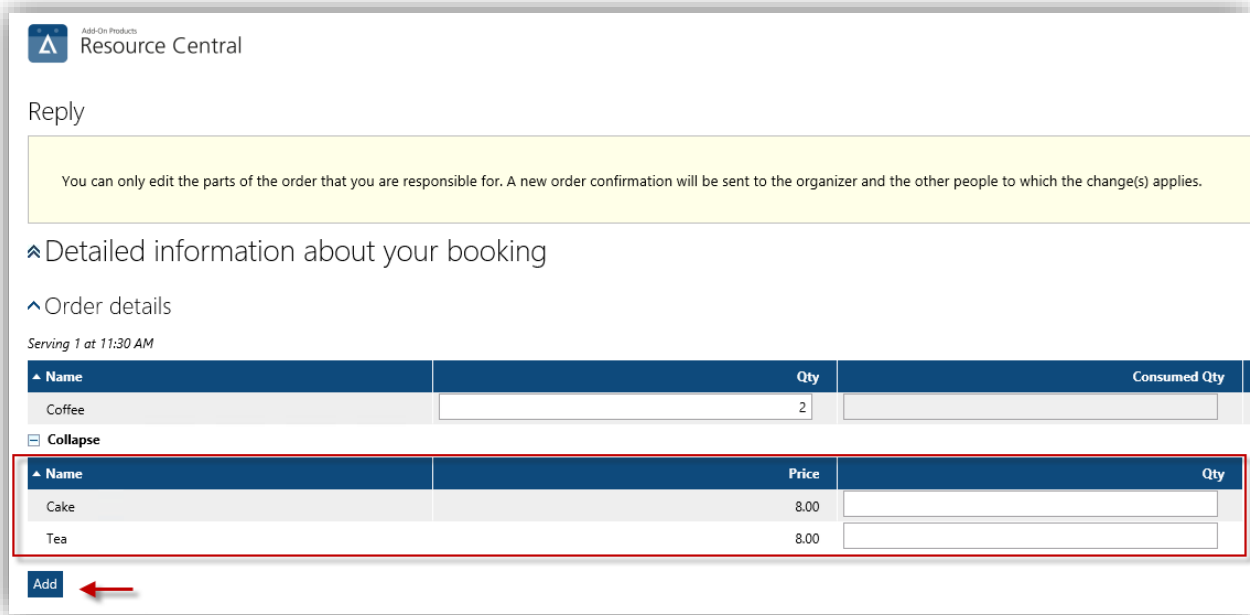
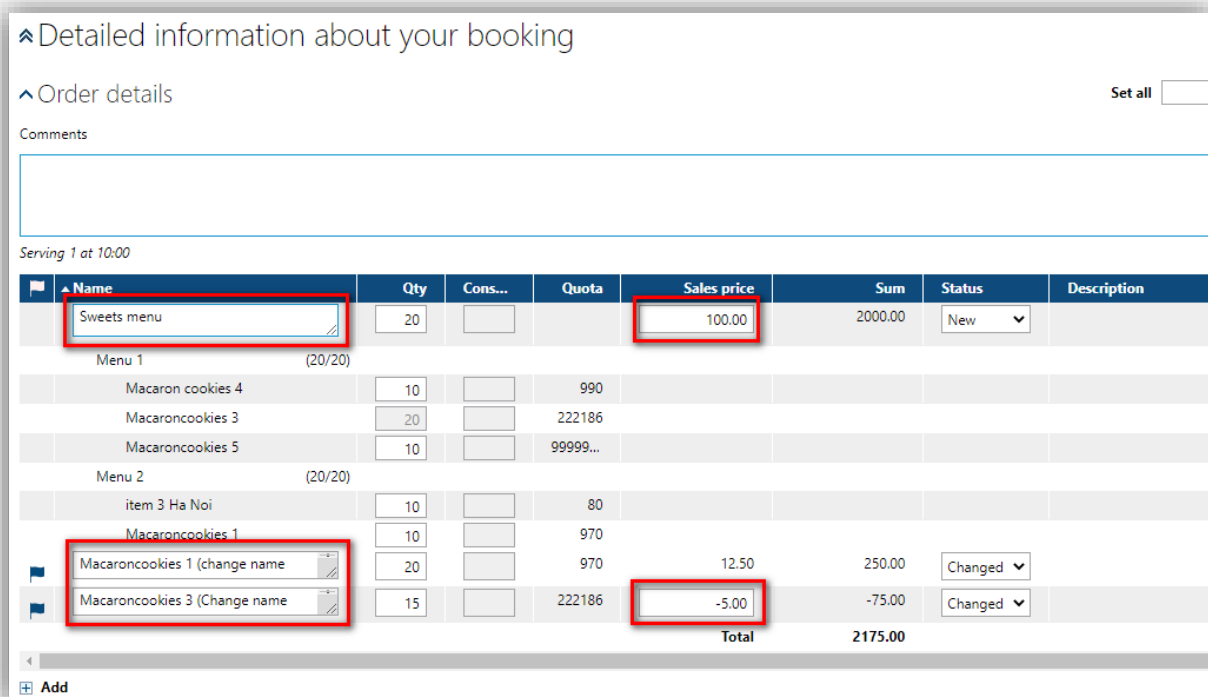

Figure 95. Order form of the Service Provider with Add Links

Now the user can give any quantity to new Items and/or Properties then click **[Add]** button. By clicking the **[Add]** button, those Item/Properties will be made part of that particular serving.

At the end, when the user clicks the **[Update]/[Update and Send Email]** button, the organizer and all the Service Provider(s) will be informed via email about the changes made to the Serving(s). However, it is to be noted that the Service Provider could only view those Items/Properties for which he has 'Assignable' role or 'Informative' role.

NOTE: If the item is editable (refer to **Flexible pricing** and **Alternative text** fields in [Item Details](#)), the service provider can edit the item's **Name** and **Sales pricing**, e.g.:



Deactivation of Email to Organizer

Service Providers of the Resource Central system do have the option to control Email notification to organizer. When making appropriate changes to their part of the order, they are facilitated in the form of a button adjacent to the **[Update]** button, as shown in the figure below:

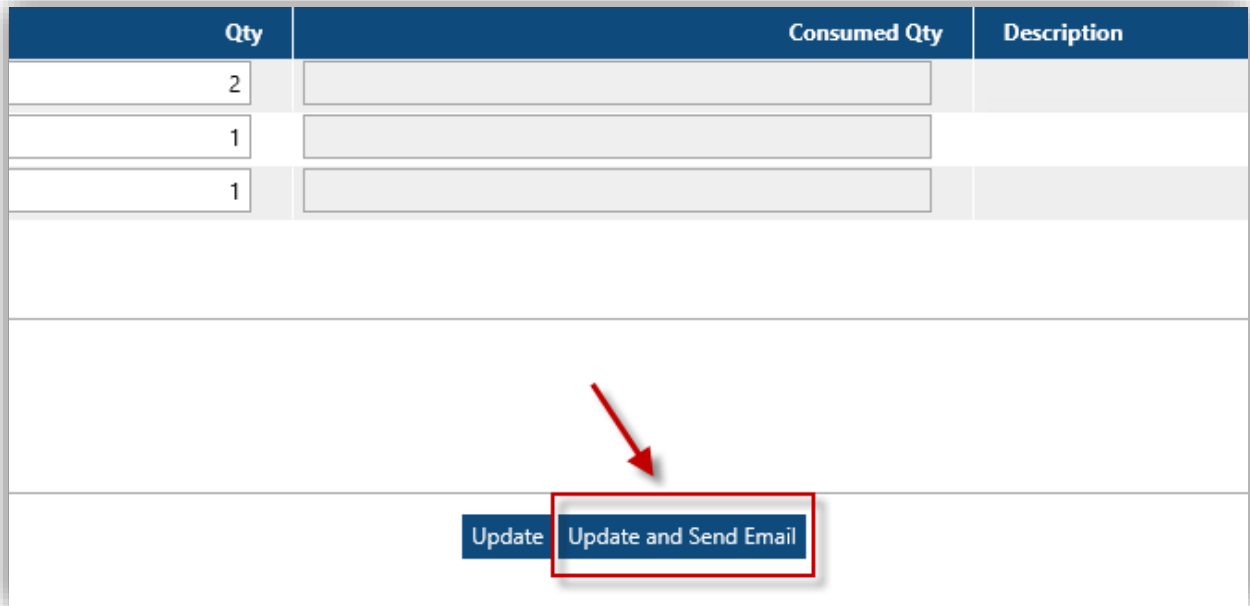

Figure 96. Order form of the Service Provider

If the user clicks the **[Update]** button, then the corresponding changes will be made permanent but No information as per Email would be sent to the organizer regarding those changes. On the other hand, if the user clicks **[Update and Send Email]** button, then the organizer will be informed of the changes made, in the form of a Changed Reservation Email, as per normal order flow.

Order Status

Each item in an Order might have one of the following statuses:

- New
- Confirmed
- Changed
- Arranged
- Locked

The business rules as per status will be discussed in the following subsequent sections.

“New” status

When a new order is placed, all items in the mail are marked with **“New”** status in the mail sent to the nearest located Service Provider.

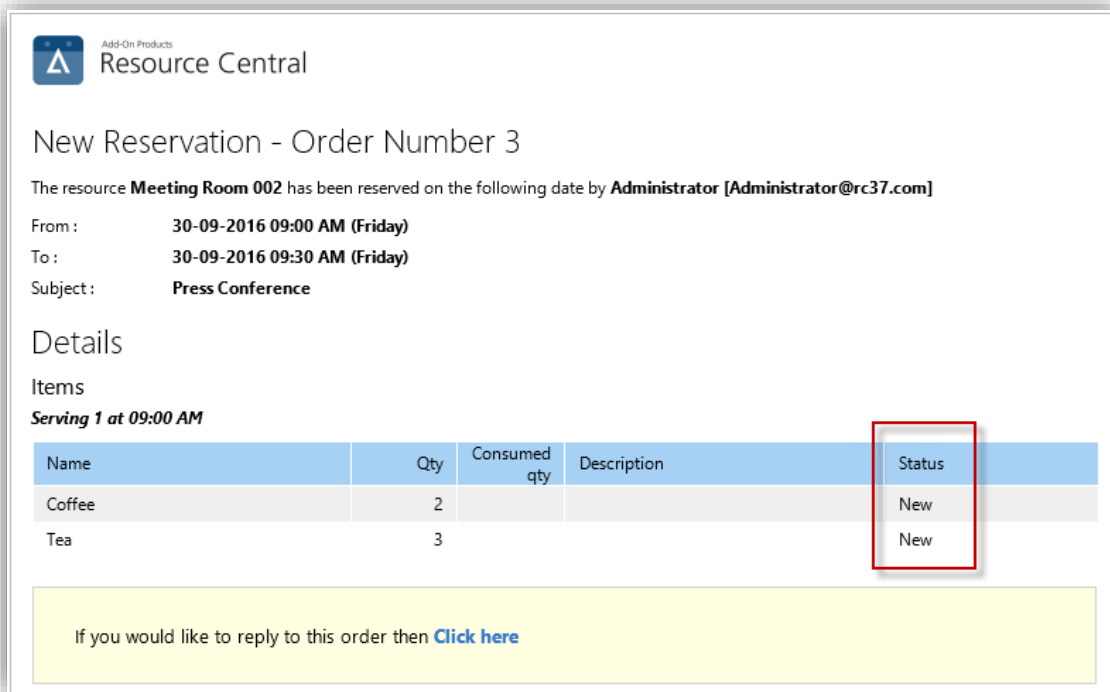

Figure 97. Order Items with New status

Different statuses available after 'New' status

Clicking the link in the service order e-mail sent to responsible role/person will open a browser window with a reply form. You can edit the part of the order that you have 'Assignable' role. Overall, three heads are shown in the order form of the Service Provider:

1. **Order Details** (shown if order items are associated with the role of the person)
2. **Properties** (shown if it is associated with the role of the person)
3. **Comments** (additional comments to be sent to organizer)

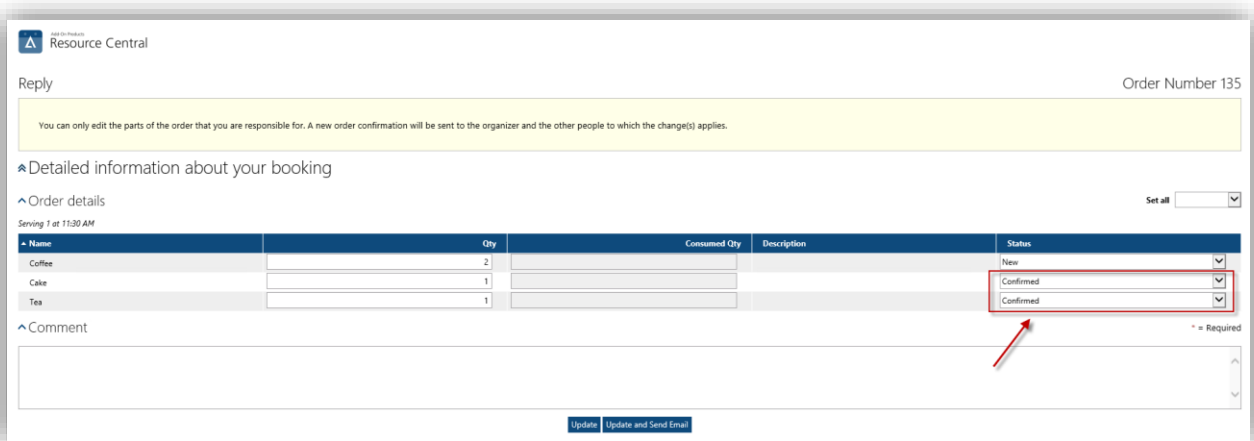

Figure 98. Order Form of Service Provider

Click on the combo box to select a status for the item in a serving. Following statuses can be assigned by Service Provider from status combo box:

- New
- Confirmed

- Changed
- Arranged
- Locked

NOTE: Service Provider can choose not to send email notifying the status change via RC backend. For more details, please refer to [Orders](#) section.

“Confirmed” status

Service Provider can confirm an item status by selecting **Confirmed** status from the status combo box in the order form.

Changed order email sent to the meeting organizer will show **Confirmed** status against the items for which **Confirmed** status is selected by the Service Provider.

“Changed” status

Changed status can be assigned to an order item in the following cases:

- Service Provider selects **Changed** status from the combo box against an order item.
- Responsible role/person related to order items, or the meeting organizer changes the order quantity value (any value other than zero or blank) in his/her corresponding order form.

Changed order email will be sent to meeting organizer only if Service Provider changes the quantity of an order item or selects **Changed** status against an order item. If meeting organizer changes the quantity of an order item from his/her order form, **changed order email** will be sent to him/her and nearest located Service Provider.

All changed order emails will show **Changed** status against order items whose quantity is changed by meeting organizer/Service Provider or when **Changed** status is assigned to the order item by the Service Provider as shown in figure below:

If you want to change something in the order then please [Click here](#)

Replies

Date	Person	Message
30-09-2016 04:49 AM	HOST	Change Coffee from 2 to 3

Details

Items

Serving 1 at 11:30 AM

Name	Qty	Consumed qty	Price	Total	Description	Status
Cake	1		8.00	8.00		Confirmed
Coffee	3		5.00	15.00		Changed
Tea	1		8.00	8.00		Confirmed
Catering Total:				31.00		

Figure 99. Items with Changed status in changed order email

“Cancelled/Declined” status

If Service Provider related to order items changes the order quantity value to **‘0’** or blank, the **Declined** status is assigned to that item. Changed order email is sent to meeting organizer and **Declined** status is assigned to this order item as shown in the figure below:

If you want to change something in the order then please [Click here](#)

Replies

Date	Person	Message
30-09-2016 04:49 AM	HOST	Change Coffee from 2 to 3
30-09-2016 04:56 AM	HOST	Change Cake from 1 to 0

Details

Items

Serving 1 at 11:30 AM

Name	Qty	Consumed qty	Price	Total	Description	Status
Cake	0		8.00	0.00		Declined
Coffee	3		5.00	15.00		Changed
Tea	1		8.00	8.00		Confirmed
Catering Total:				23.00		

Figure 100. Email – Items with Declined status

Price of order items with **Declined** status are deducted from the **Catering Totals**.

Meeting organizer can re-enter quantity for order items with **Declined** status by entering new quantity value of the item from his/her order form and by sending the order. The status of these items will be marked as **Changed** in the Changed order email sent to both meeting organizer and nearest located Service Provider.

An order can be considered “cancelled/declined” when it is deleted after the deadline. Organizer might delete the order in Outlook after the deadline time of items (in that order), therefore RC changes status of all items to “Arranged” as well as deletes all attendees and properties of the order. In this case, order status is “Arranged” and the text “Meeting is cancelled” shows up at ‘Reservation at’ column:

Orders - Thursday, 05/26/2022

Resource Central System Administrator

NEW PRINT PRINT ALL Per Order INFORMATION ONLY SET ORDER STATUS Select a Status DECLINE ACCEPT SEND TAX RECEIPT Order No.

Order No.	Delivery	Reservation at	Ends at	Subject	Organizer	Resource	Pers...	Order status	Tax Receipt	Host
11963	08:00 AM	05/26/2022 08:00 AM	05/26/2022 08:30 AM	Project Meeting	Mark Olin (mol@add...)	Meeting Room 101		New		
12107	11:00 AM	05/26/2022 11:00 AM	05/26/2022 11:30 AM	Press Conference	Mark Olin (mol@add...)	SI Room 5		New		
12756	11:30 AM	05/26/2022 11:30 AM	05/26/2022 12:00 PM	Guest Meeting	Kimberly Jackson (kjs...)	Meeting Room 102		New		
12757	11:30 AM	05/26/2022 11:30 AM	05/26/2022 12:00 PM	Guest Meeting	Kimberly Jackson (kjs...)	Meeting Room 201		New		
12758	11:30 AM	Meeting is cancelled.	05/26/2022 12:00 PM	Guest Meeting	Kimberly Jackson (kjs...)	Meeting Room 203		Arranged		

Status legends: New Changed Confirmed Transferred Arranged Locked Cancelled/ Declined Information Order

Figure 101. RC backend – order with ‘Cancelled’ status

“Arranged” status

Arranged status can be assigned to an order item by the Service Provider by selecting **Arranged** value from status combo box in his/her order form as shown in figure below:

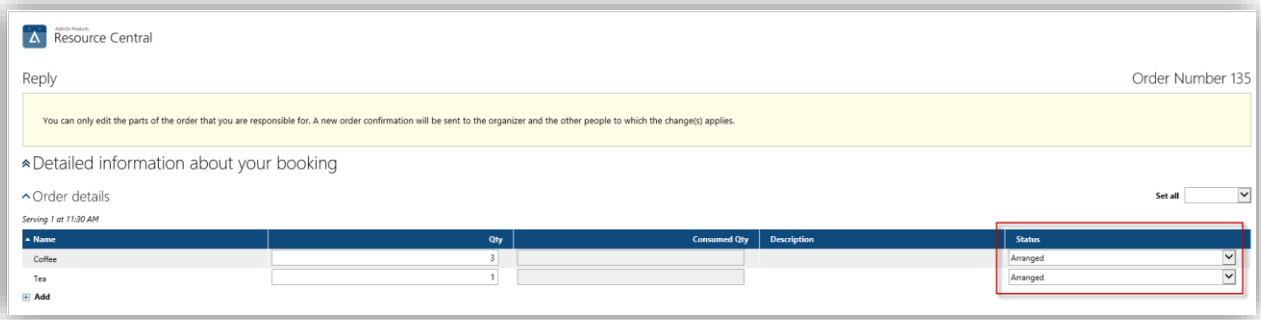

Figure 102. Items with Arranged status

Changed order email is sent to the meeting organizer displaying the **Arranged** status against the item.

NOTE: Quantity values of order items with **Arranged** status cannot be changed by either meeting organizer or Service Provider from their respective order forms, which is different from what they can do to order items with **“Changed”** and **“Declined”** statuses.

“Locked” status

Locked status can be assigned to an order item by Service Provider from status combo box.

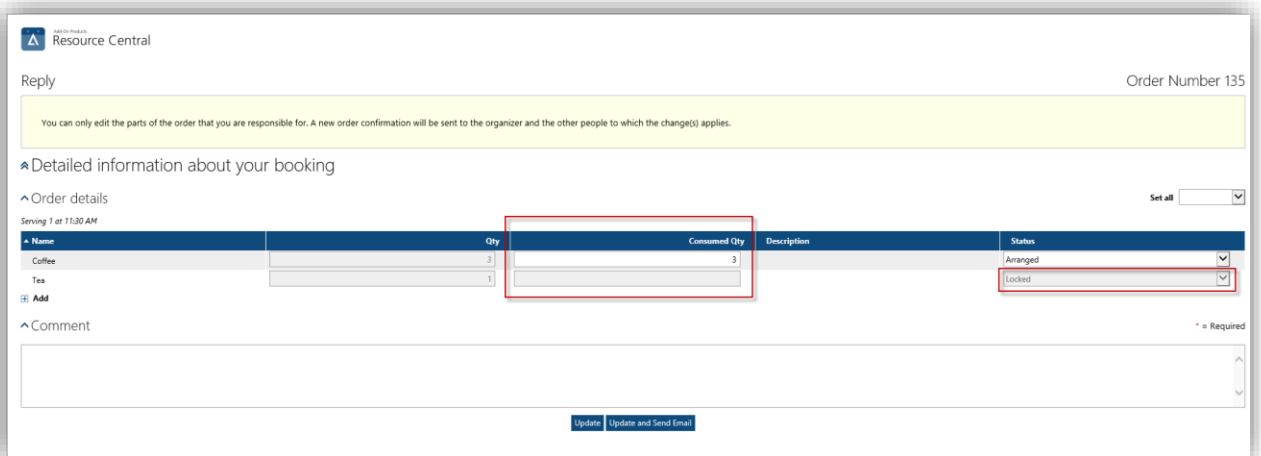

Figure 103. Items with Locked status

Field for Consumed quantity (Consumed Qty) is displayed if:

- An item has been set to **“Arranged”** or **“Transferred”** or **“Locked”**. If the status is **“Transferred”** or **“Locked”**, this “Consumed Qty” field is not editable.
- Booking start time has passed.

If an item in an order which does not have consumed quantity specified, then when the consumed quantity appears, it will take the value from quantity as its default value.

When a consumed quantity field appears for an item, its quantity field is grey-out. Service provider can now only edit the consumed quantity instead of quantity.

Below is a preview of an email sent to the meeting organizer:

If you want to change something in the order then please [Click here](#)

Replies

Date	Person	Message
30-09-2016 04:49 AM	HOST	Change Coffee from 2 to 3
30-09-2016 04:56 AM	HOST	Change Cake from 1 to 0
30-09-2016 05:03 AM	HOST	Change status of Tea to Locked

Details

Items

Serving 1 at 11:30 AM

Name	Qty	Consumed qty	Price	Total	Description	Status
Cake	0		8.00	0.00		Declined
Coffee	3		5.00	15.00		Arranged
Tea	1		8.00	8.00		Locked
Catering Total:				23.00		

Figure 104. Catering Totals calculation as per Consumed Quantity

Consumed Quantity field is mandatory. If Service Provider leaves blank value in Consumed Quantity field against an order item, i.e., value for Consumed Quantity is “0”, then the bill will be calculated as if that item is not consumed.

If **Locked** status is assigned to an item, then neither Quantity nor Consumed quantity can be modified by Service Provider and meeting organizer.

Order status calculation

Status shown for individual service provider

In terms of individual service provider, each person’s Order screens only show status of his/her own assigned items & properties. The Order status is determined by taking on the highest priority level among all assignable items/properties.

The priority levels are listed as follows:

Status	Priority level
New	1
Changed	2
Confirmed	3
Arranged	4
Locked	5
Declined	6
Transferred	7
Deleted	8
Cancelled	9

For example: an order has 3 assignable items, 2 of them are 'Confirmed', 1 of them is 'Changed'

- The order status will become 'Changed' since it has the highest priority among the 3 included items.

Also as mentioned, items & properties with 'Informative' role type are considered view only. They do not have any effect on the individual's Order status.

Take the same example above: if that order has 1 more informative item with status 'New'.

- The order status is still 'Changed' because informative item does not affect the status. Therefore, order status does not become 'New' despite its higher priority.

Status shown for System Administrator

System Administrator (or SysAdmin) has 'Assignable' role type for all items & properties; therefore he/she can see and handle every Orders, every status. In a sense, SysAdmin can see the progress of an entire order.

The order status on SysAdmin's Orders screen is calculated by comparing the Order status of all involved service provider, using the priority table above.

I.e.: this is the status calculation of an order that requires 3 service providers.

Person	Order status	Priority level
Caterer 1	Confirmed	3
Caterer 2	Changed	2
Facility Provider	Declined	6
SysAdmin	Changed	

As you can see, Sysadmin's Order status takes on one with highest priority ('Changed' in this case); therefore, the status is shown as 'Changed'.

Setting a status for all Items or Properties

In Resource Central, Service Provider has the option to mark a single status to all the items or property with a single click. For this, a head drop down is available over the individual status drop downs of the item(s), as shown in the figure below. You can select any status from the drop down, which will ensure that by sending this order, the status of all the corresponding Line Item(s) would be changed to the specified status.

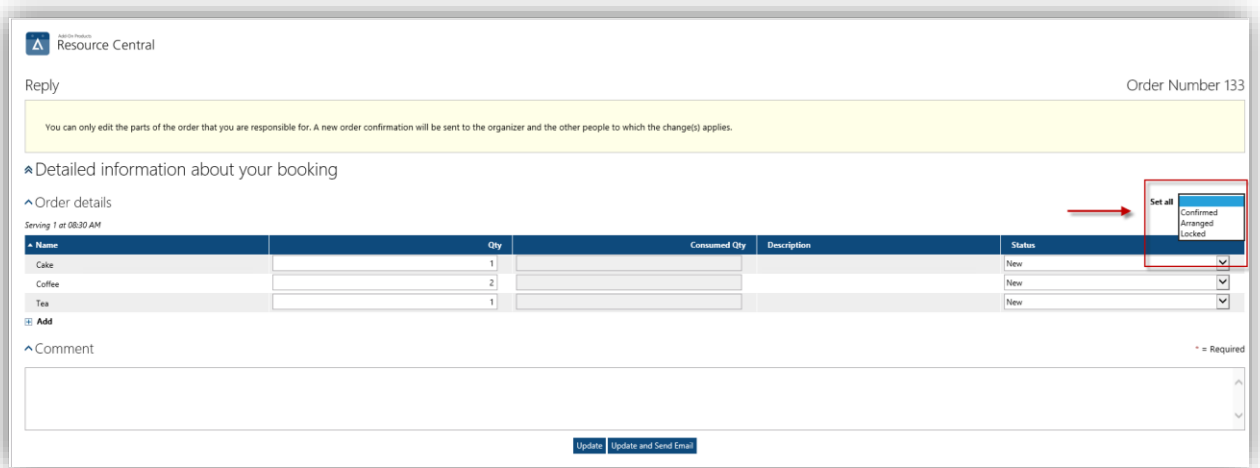

Figure 105. Order form of the Service Provider-Confirmed, Arranged or Locked All functionality

In case **Locked** status is assigned to all order items by Service Provider, after that meeting organizer and Service Provider cannot modify an order item quantity or a property value as shown below:

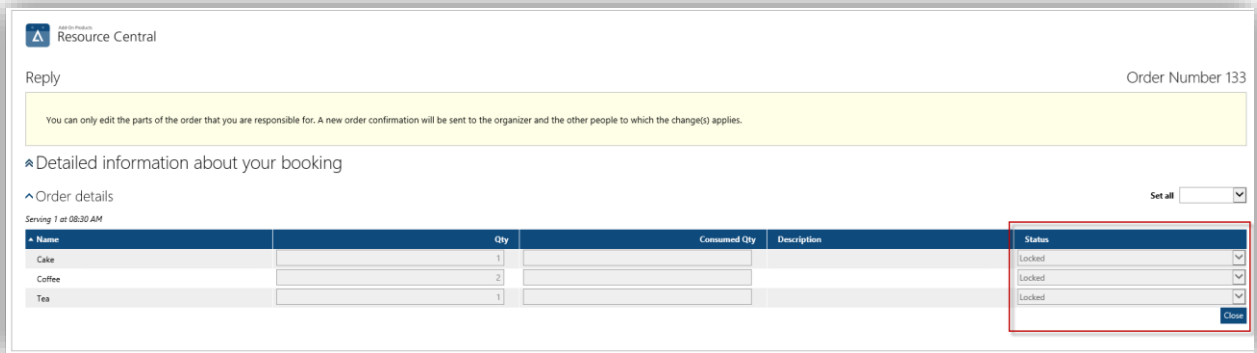

Figure 106. All order items with locked status

Meeting organizer will receive **changed order email** with no order form link when all order items have **Locked** status, as shown in figure below:

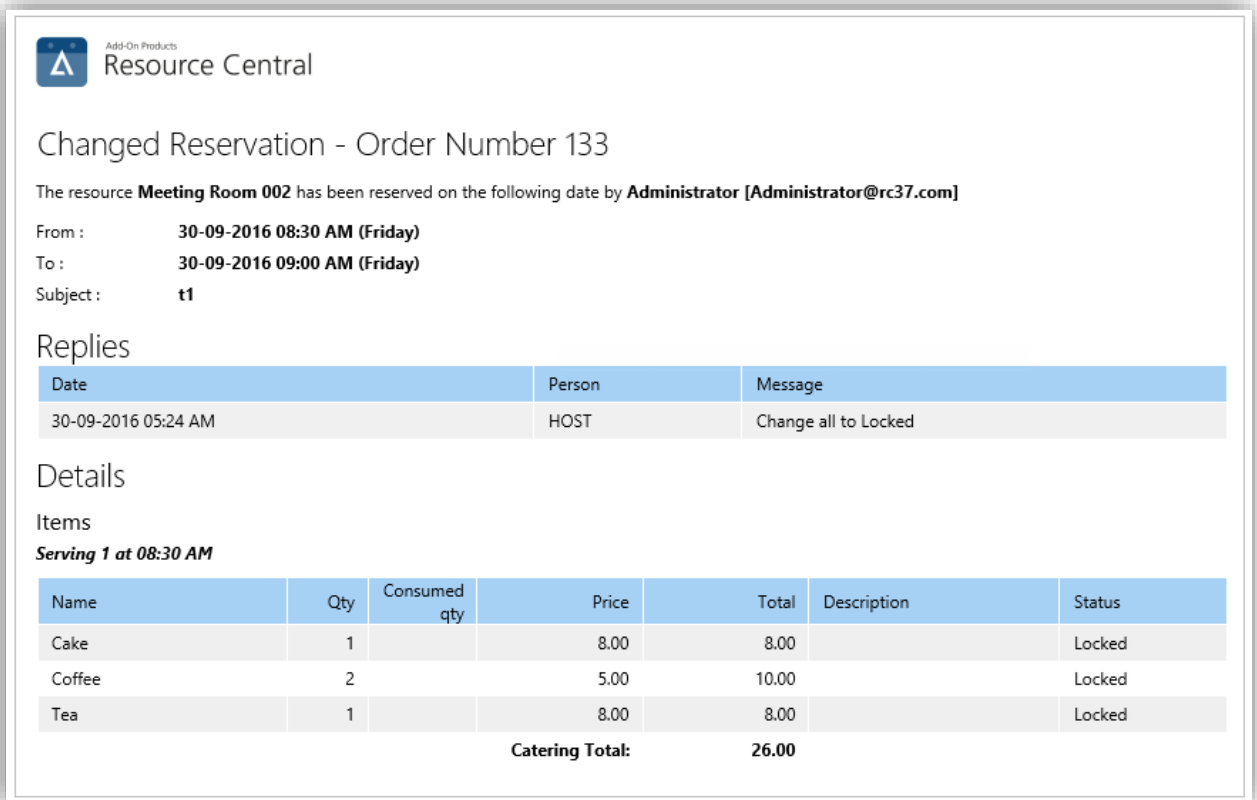

Figure 107. Order Email sent to organizer with Locked status for all order items

CHAPTER 3.

Resource Central Outlook Add-in

Resource Central Outlook Add-in provides an alternative to the Resource Central COM Add-in. In terms of how to set it up, please refer to **RC Outlook Add-in - Installation Guide**.

NOTE: Outlook Add-in is available for both Outlook Desktop and Outlook on the web (Outlook Web Access). For better illustration, the Outlook desktop client will be used (instead of Outlook on the web) to describe all functionalities.

Basically, Resource Central Outlook Add-in works similarly to Resource Central COM Add-in but with slightly fewer features and more convenience in use and deployment. The feature is available in Outlook desktop client and in Outlook on the web.

It also consists of 2 components: ResourceFinder and My Meetings.

ResourceFinder in Outlook Add-in

ResourceFinder Interface

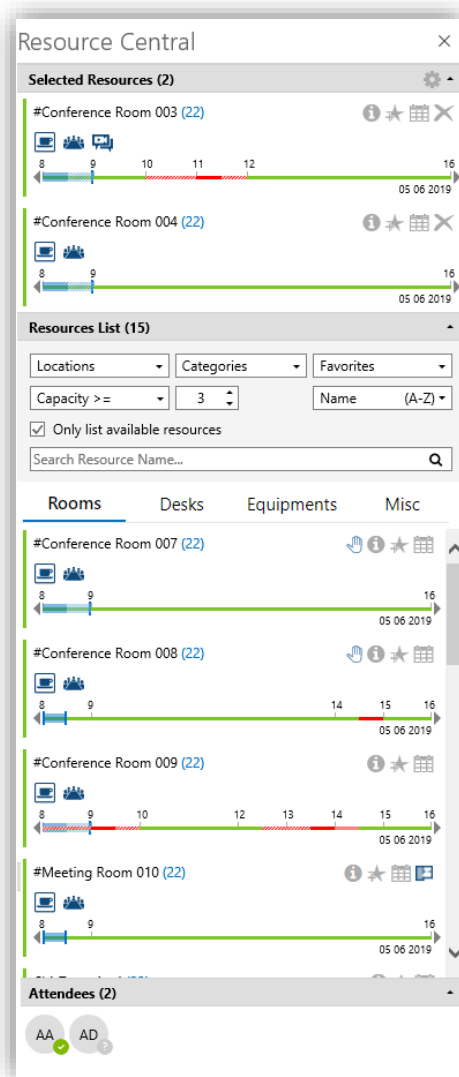

Normal booking

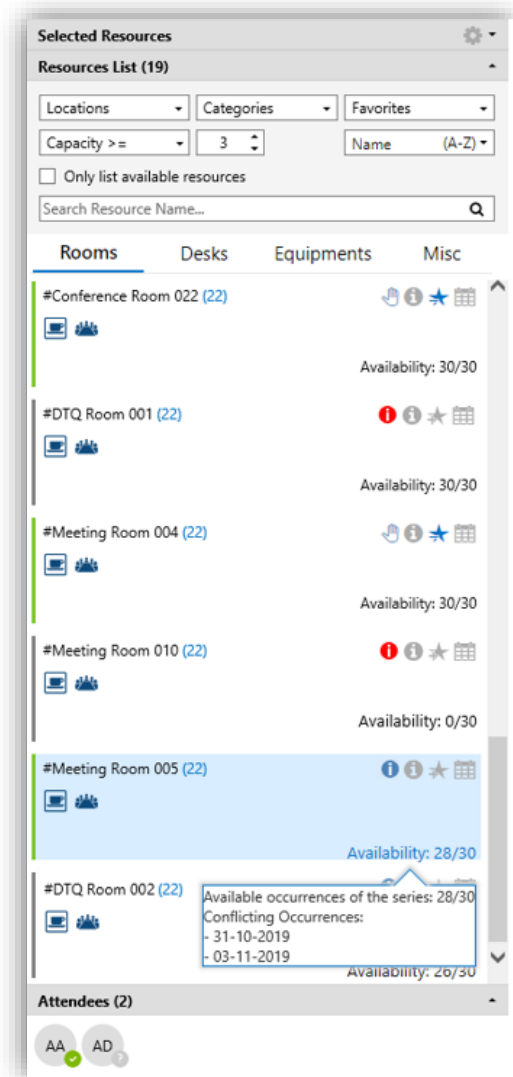

Recurring booking

- **Control buttons:**

	Open Settings
	Booking this resource requires approval by the resource's delegate. Your request will be forwarded, pending approval.
	You cannot book this resource because your meeting request conflicts with the resource's booking policies.
	You do not have permission to book this resource.
	View Resource Details
	Add Resource to My Favorites
	View Calendar
	Show Floorplan
	Remove the resource

You can refer to **RC Outlook Add-in - User Guide** for more details about the availability ratio, which is displayed when you book a recurring meeting.

If the resource list on the screen does not include the resource that you are looking for, click **[List more Resources]** to have more resources displayed in the list.

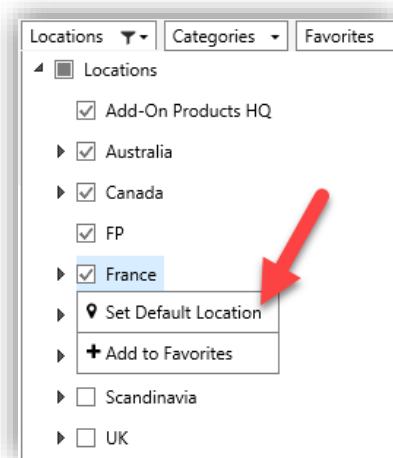

In case you often look for resources in a certain location, you can set a default location to save time. To do that, right click on a location that you want to set as default, select **[Set Default Location]**.

For each resource you can see an availability timeline for that resource. This can be configured with parameter **OutlookAddin.TimeLine.Visible**. On the timeline, you can see how your meeting fits the resources' availability with a blue box. Other employees' meetings are marked red and below is an example with buffer time displayed as a red line of backslash.

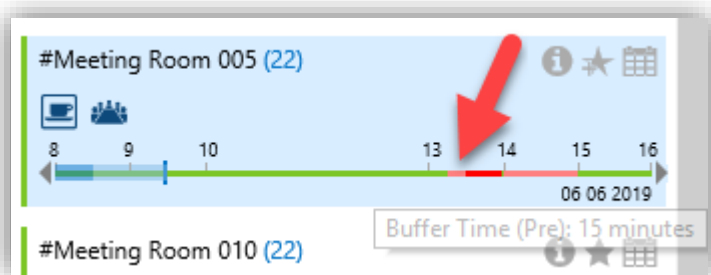

Figure 108. Buffer time on timeline

Selecting a room will move the room to the outlook appointment and to the selected resources area of the add-in.

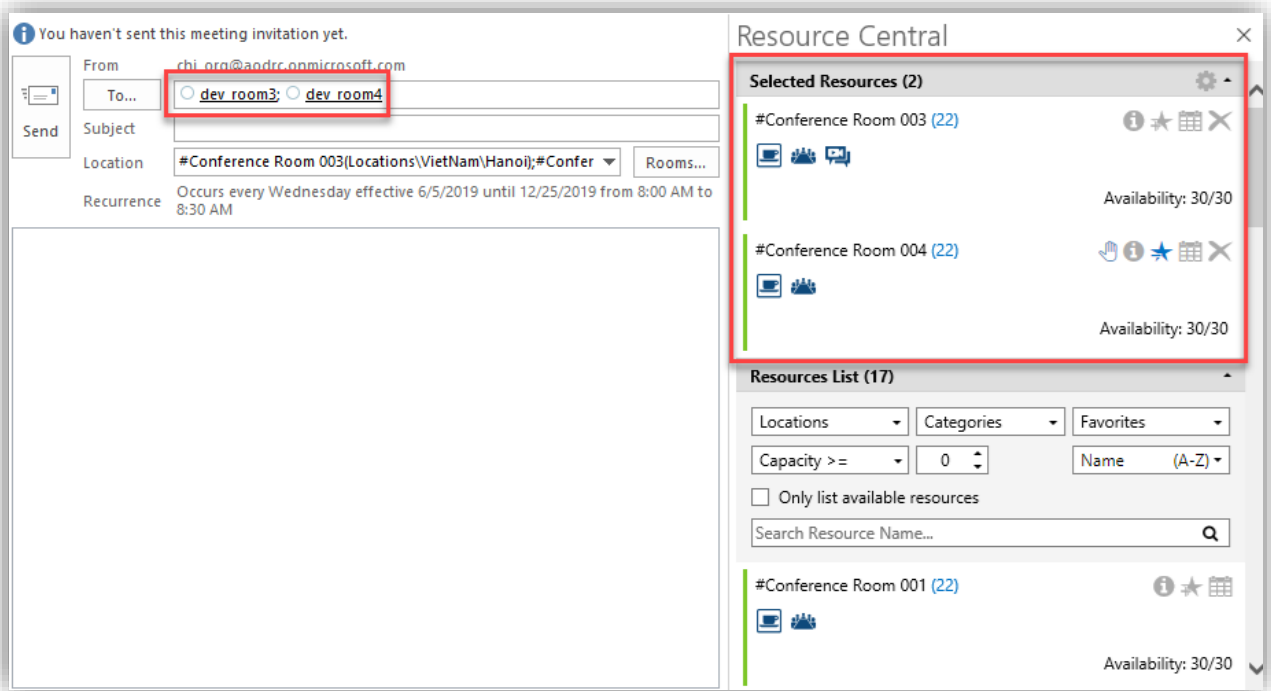

Figure 109. Selected rooms in ResourceFinder

At any time, you can add attendees to the meeting and the ResourceFinder add-in will adjust.

The number of attendees you add to the meeting will directly make an impact on room search: the room capacity in Filter section is automatically changed according to the number of added attendees including the organizer:

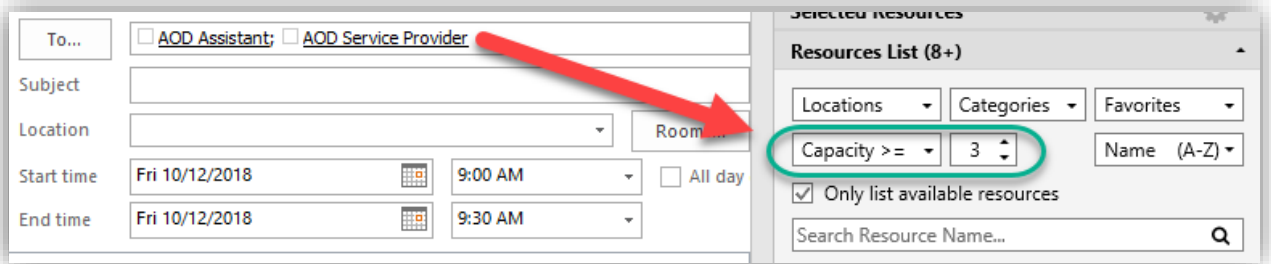

Figure 110. Attendees – filter capacity

Attendees are displayed at the bottom of the **ResourceFinder Add-in**.

The color code shows the availability of the attendees, in which red means that they are unavailable in the selected meeting time and green means that they are available.



Figure 111. Attendees list

Clicking on an attendee's name will open its calendar as shown in the following figure, on which you can check the attendee's availability for the meeting:

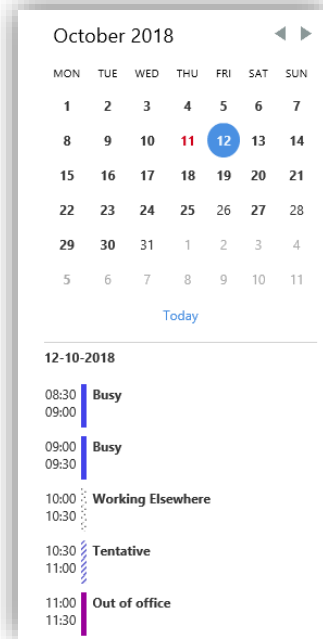
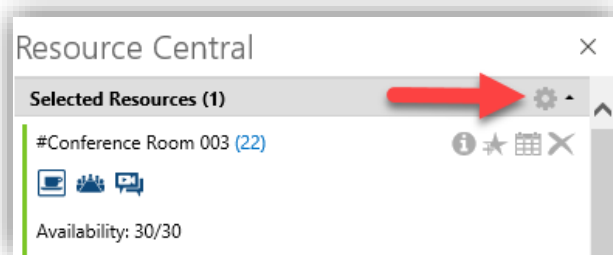

Figure 112. Attendee's calendar

Add-in settings



From the main screen of ResourceFinder or in My Meetings, you can open **Add-in Settings** by clicking on the cogwheel icon at the upper right corner.

In **Settings** panel, configurations for language, assistant organizer function and datetime format can be made.

Language Setting

You can make configurations for Language to be used in ResourceFinder by clicking on the [**Settings**] icon at the upper right corner of the interface. The following panel shows up:



Figure 113. Settings – Language

Click [**Apply**] to finish.

Assistant Organizer

To enable other organizers like secretaries or Personal assistances to book meetings and place orders in RC on behalf of other organizers, Resource Central provides an additional feature, namely “**Assistant Organizer**”.

The feature allows the organizer to assign all related work to the assistant as the notifications can be directed directly to the assistant who will correspond with the different service providers on the different service orders.

The assistant with access to the organizer’s calendar can also schedule the meeting directly in the organizer’s calendar and assign all notifications to the assistant.

- Enabling the feature in ResourceFinder

If this function is enabled by the parameter, the icon Assistant is not available in the **ResourceFinder** → **Order Form**. It is only available after the function is enabled in **ResourceFinder Settings**.

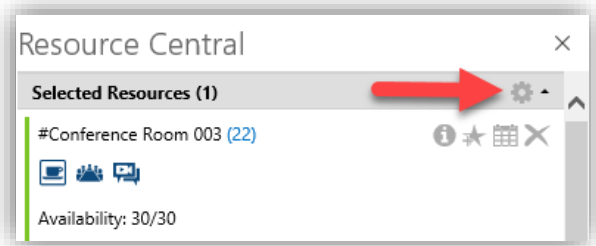

When this function is enabled in the system, the icon Assistant needs to be activated in the **ResourceFinder Settings**.

Under Default Assistant, you can setup an assistant organizer that will be used as standard on all your orders. E.g., if all your meetings are always handled by the same assistant.

You can also set up a default email flow (who will receive notification emails) by selecting from the dropdown list:

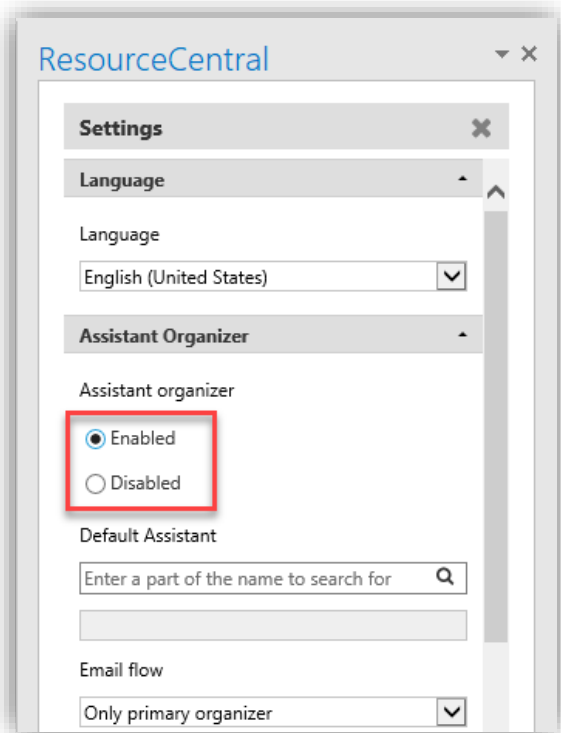
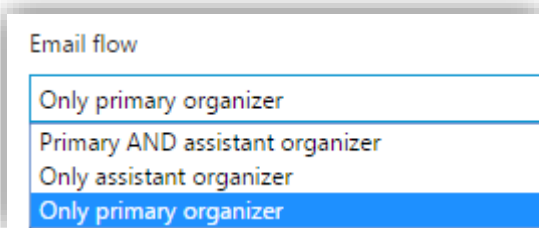

After clicking [**Apply**], the icon **Assistant** is available in **ResourceFinder** → **Order Form**. But it is only applied to the booking if you click on it

Disabled Assistant

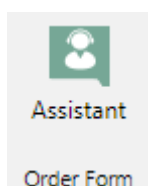

Enabled Assistant

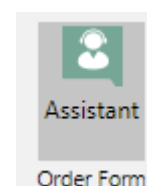

Enabling the function will make the assistant organizer available in the **ResourceFinder** → **Order Form**: there will be a section in the order form named **“Meeting Organizer”** on top when you make a booking:

MEETING ORGANIZER

Organizer: JohnSmith

Assistant organizer: [...]

Email to: Organizer Assistant organizer

Figure 114. Order Form – Meeting Organizer

The options (assistant and email flow) established previously in **ResourceFinder Settings** will be displayed here. You can make changes according to any need of the particular meeting or disable it if it is a meeting, where you do not need an assistant organizer.

The function is also available in My Meetings where the organizer can see who the assistant is at different meetings and the assistant can see the meetings of different organizers that the assistant supports.

This is what the primary organizer (in this example, it is John Smith) sees in My Meetings:

Day	From	To	Subject	Resource	Location	Own...	Assista...	Orders	Is Recu...
19	19-M...	19-May-...	Project Meeting			john_s...	sensi_h...		✓

Figure 115. My Meetings opened by Organizer

This is what the assistant organizer (in this example, it is Sensi Haukner) sees in My Meetings:

Day	From	To	Subject	Resource	Location	Own...	Assista...	Orders	Is Recu...
19	19-M...	19-May-...	Project Meeting			sensi_h...			✓
19	19-M...	19-May-...	Press Conference			sensi_h...			✓
19	19-M...	19-May-...	Board Meeting			sensi_h...			✓

Assistant Organizer

From	To	Subject	Resource	Location	Own...	Assista...	Orders	Is Recu...
john_smith@aoprc.onmicrosoft.com(john_smith)								
19-May-...	19-May-...	Project Meeting	Meeting Room 202	Locations	john_s...	sensi_h...	✓	✓

Figure 116. My Meetings opened by Assistant Organizer

Date/Time Format

You can also set up date/time format in Settings panel.

Go to Settings and roll down, you will see the Date/Time Format section.

Select your preferred First day of the week, Time Format, Date Format and Date Separator, then click **[Apply]** to finish.

Date/Time Format

First day of week
Monday

Time Format
HH:mm (13:10)

Date Format
dd-MM-yyyy (26-05-2022)

Date Separator
.

Apply

Default Category

In this section, you can set up default categories (of resources) to be displayed when opening Outlook Add-in.

Go to Settings and roll down to the bottom of the panel, you will see the Default Category section.

Select your preferred default categories, then click **[Apply]** to finish.

Resource Central

Settings

Language

Assistant Organizer

Date/Time Format

Default Category

DefaultCategories

- Small Rooms
- Large Rooms
- Cars
- Function Rooms
 - Meeting Room
 - Training Room

Clear Apply

Floor Plan

When booking a resource, it is useful if you can navigate to the resource and see the floor plan / ground map on the screen. The Floor plan feature is created to serve this purpose.

This function is controlled by the parameter **ResourceFinder.FloorPlan**. For more details about this parameter, please refer to **RC Parameter Guide**.

Refer to [Locations](#) section for more details on how to upload the location image, do the resource mapping, use the icons or icon images as part of the navigation.

Alternative Resource for recurring meeting in Outlook Add-in

When you book a series where some of the occurrences have conflicting resource, you will see the following message:



Figure 119. Conflict message

The message tells you about the dates that have conflicts, but you can still click **[Send]** to send the meeting.

To select alternative resources for the conflicted dates, open the series in your calendar after the series and the resource booking has been accepted by Exchange. It will prompt an 'Open Recurring Item' message, in which you choose 'The entire series', and click **[OK]**.



Open the Resource Finder Outlook Add-in and you will now see **[Alternative Resource]** button:

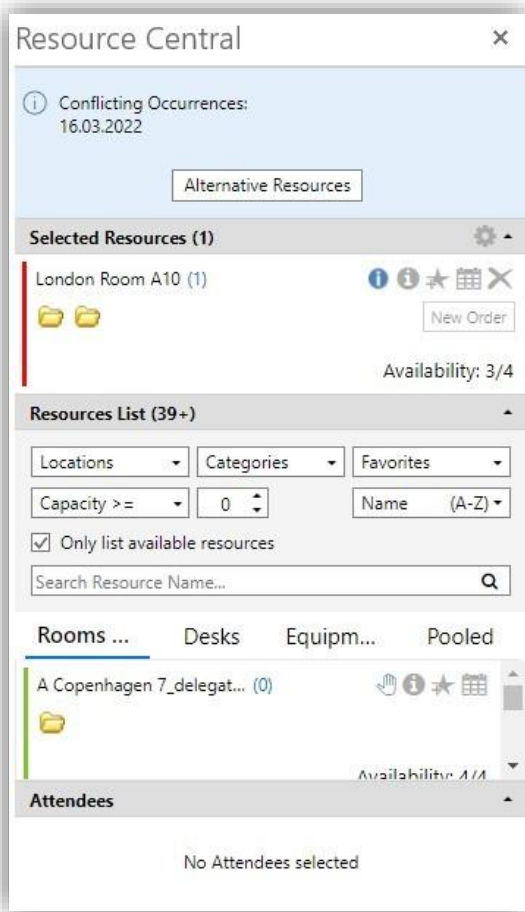

Figure 120. Alternative Resource

Notice that it shows dates of the occurrences with conflicts, but there is no resource next to it.

Click the button to open Alternative Resources section. Here you can select conflicting dates, then click **[Available Resources]** to select different resources for those dates:

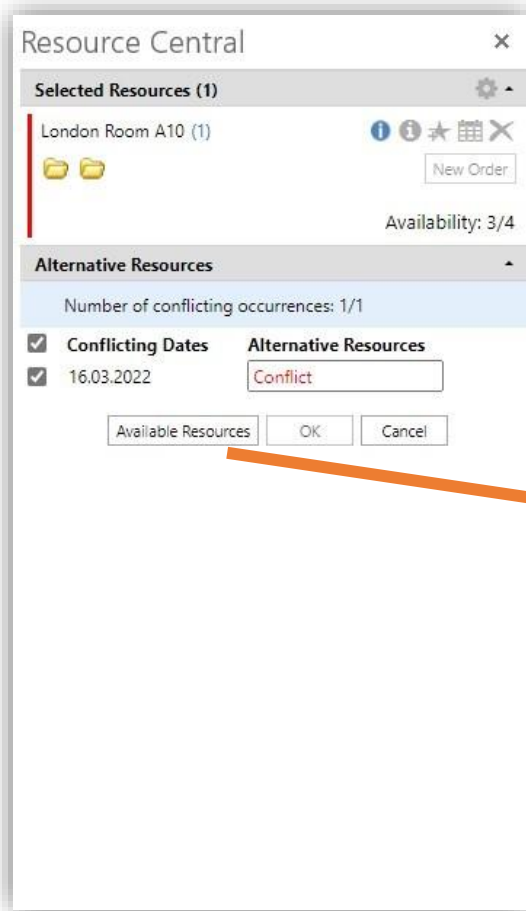

Figure 121. Alternative Resources section

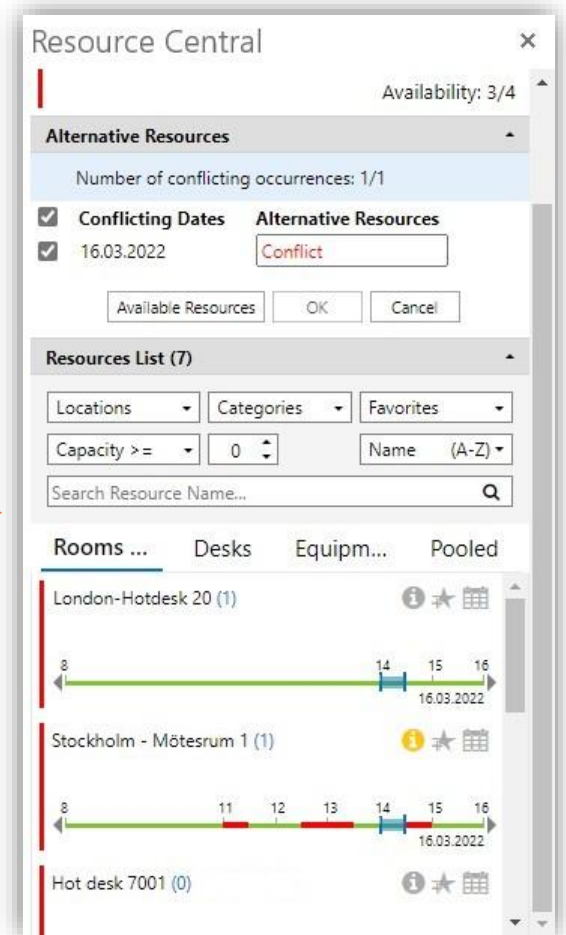

Figure 122. Alternative Resources list

Once you have selected alternative resource, click **[OK]**. You will then see a new message as the example shown below:



Figure 123. Confirming alternative resource

If you still need to change or add resources for other dates, click [**Alternative Resources**] to bring back the alternative resources panel.

If you are done, click [**Send**] to register your chosen alternative resources in Resource Central. After sending the request, please close the series instead of updating it by pressing the [**Send Update**] button in Outlook.

When reopening the series you will see that the conflicted dates are now registered with a new resource:



Be aware that once you click [**Send**], conflicting dates that are registered with alternative resources cannot change resource again. They will have to be changed on the occurrences instead. Clicking [**Alternative Resources**] button only lets you change resource for conflicting dates that still do not have alternative resource.

NOTE: If your newly selected resource is still not fully available, it only changes resource for dates that are not conflicted with the new one. You have to select another resource for remaining dates that are still conflicted.

Finally, close your Meeting Series window.

If there is message asking you what to do with this meeting request, choose '**Don't save changes**' then click [**OK**].

My Meetings in Outlook Add-in

In Outlook® you have another Icon in your toolbar named **My Meetings**. The function of My Meeting is to help you keep track of all your orders for your future meetings or create new orders.

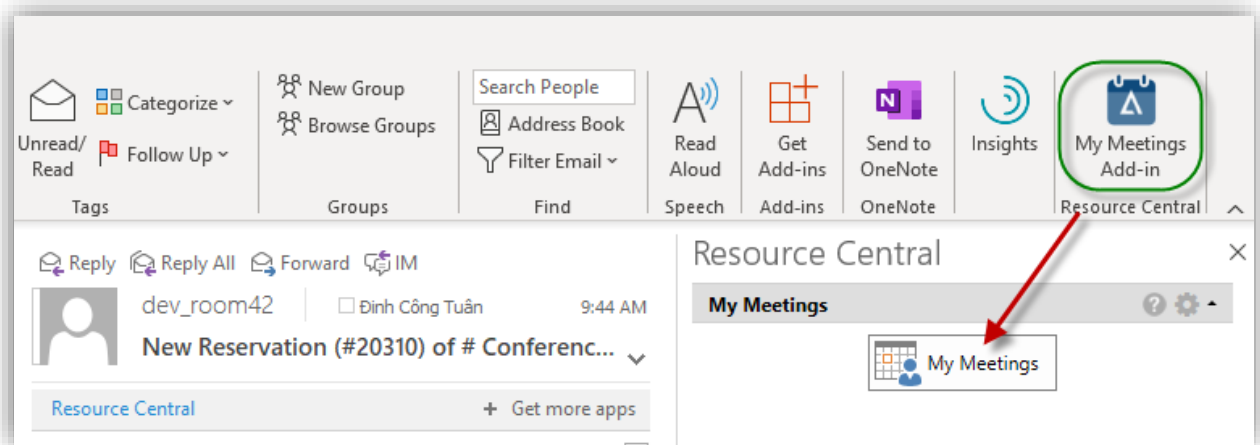

Figure 124. My Meetings

My Meetings is accessible:

1. When you open an email, the My Meetings icon is available on the ribbon of that email.

- When you stand in your Outlook inbox. Then you can see that My Meeting is accessible from Outlook's main panel (this requires **Reading Pane** is turned on. You can do this by navigating to **View** tab → **Reading Pane** → select **Right** or **Bottom**).

Click on [**My Meetings Add-in**], and from the opened add-in panel click [**My Meetings**] button.

For Outlook on the web, My Meetings is accessible when you open an email, click [**More actions**] button, scroll down and select [**Resource Central**] as in the following figure:

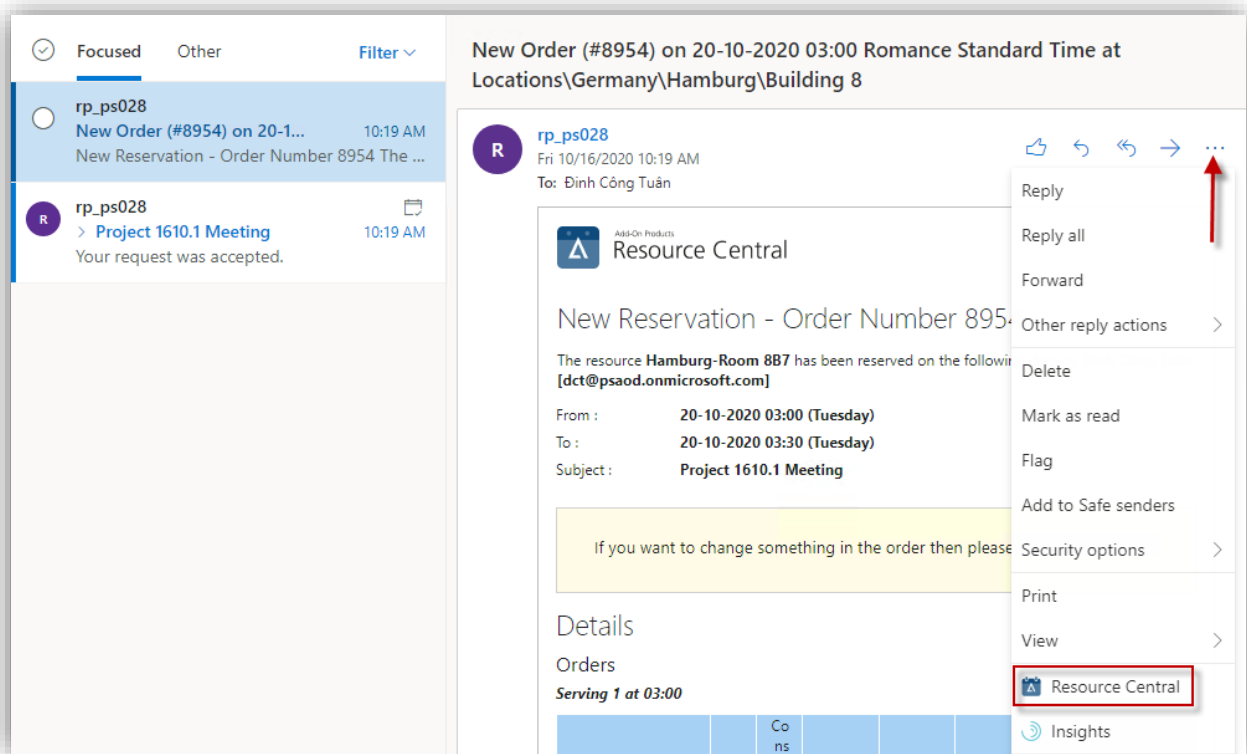

Figure 125. My Meetings in Outlook on the web

Another panel is opened after you click [**Resource Central**] from the menu. In this panel, [**My Meetings**] button is available. Click the button to open My Meetings window from Outlook on the web.

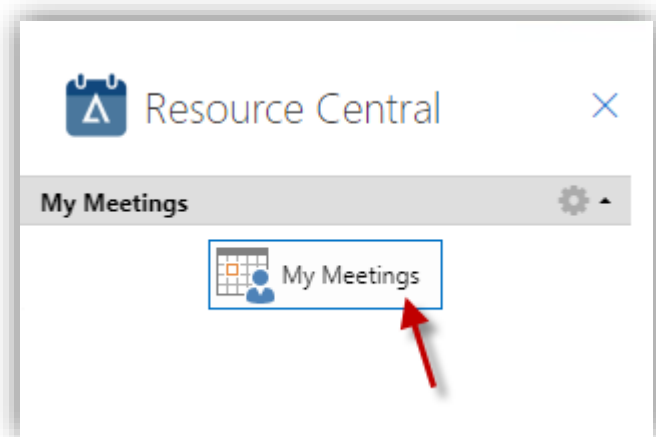

Figure 126. Open My Meetings

Refer to [this section](#) to know how My Meetings works.

CHAPTER 4.

Resource Central System Admin Interface

Resource Central **System Admin** has a web-based administration interface. To use the Resource Central system admin site, open the browser and type in the address of the webserver where **RESOURCE CENTRAL** is installed.

HTTP://<Your Server>/ResourceCentral/Admin

This will display the Login screen of Resource Central, as shown below:

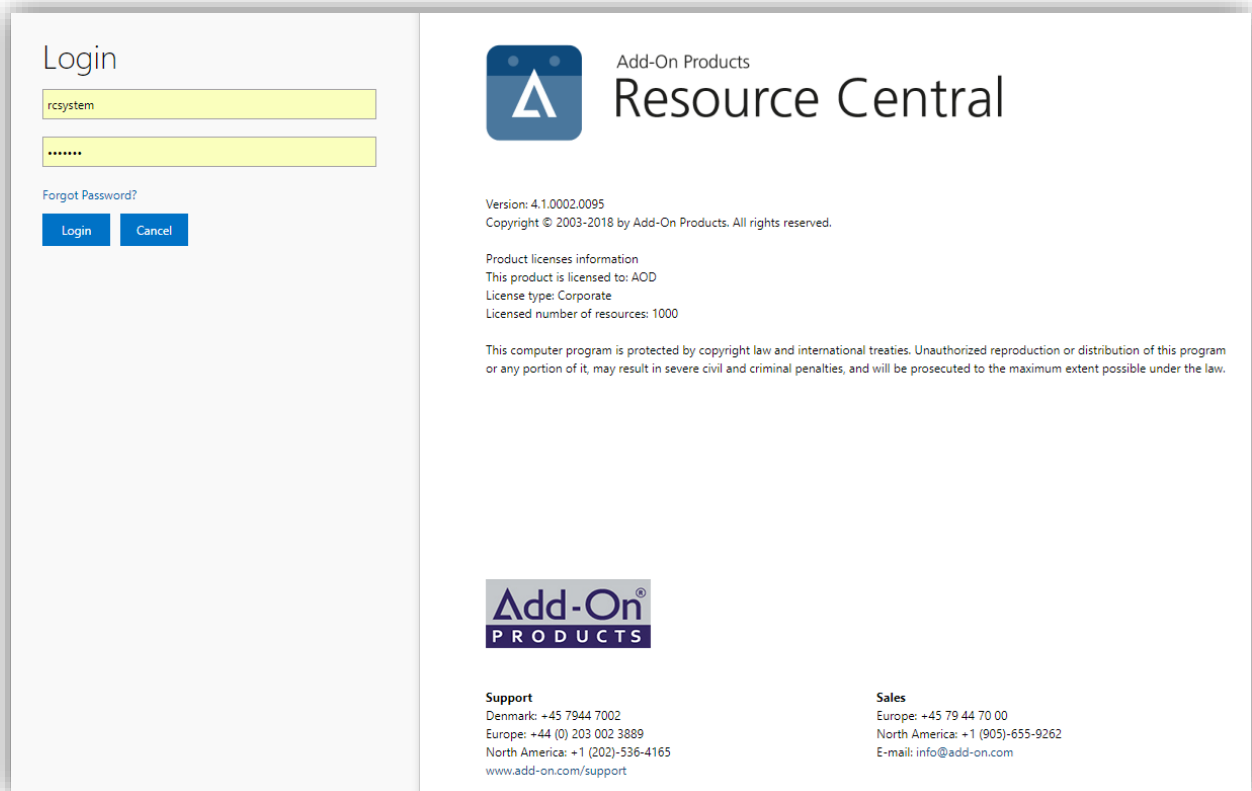

Figure 127. Resource Central Login Screen

In order to login to the application, there should be a person created in Resource Central application with full rights. You will provide the username and password on login screen as above. However, if system is configured to use the Windows authentication method, then the user will be authenticated against his/her window's user account and login screen will not be displayed.

NOTE: The logo in the login screen can be changed with images of the same size – 408px (width) x 131px (height) or images with size smaller than 1445px (width) x 361px (height), otherwise they will be stretched. If you want to add your own logo, see the description of Main Logo in [Basic Parameters](#) section.

The RC Admin interface is divided into the following 6 areas:

- Daily Tasks
- Reports
- Designer
- Location
- Security
- System

Access to each area and its **look** and **feel** is controlled by the **Role of logged in person**. Each area and its functions are described subsequently in this chapter.

Daily Tasks

The daily tasks section consists of the following areas:

- [Orders](#)
- [Reservations](#)
- [Booking Manager](#) (needs to be enabled)
- [Overview](#)
- [Items](#)
- [Menus](#)
- [Visitors](#)
- [Signage](#)
- [Tasks](#) (available if Shared Order 1.0 feature is enabled)

Orders

The Orders screen shows open orders for a given day. The orders corresponding to the selected group can be filtered on date as well. The Orders screen is also role based, i.e., the logged in person can only view those Item(s) and Properties for which he/she is responsible for. Otherwise, the logged in person would not see any records on this screen.

Order No.	Delivery	Reservation at	Ends at	Subject	Organizer	Resource	Persons	Order status	Tax Recel...	Host	Comment
15394	03:00	2024/05/09 03:00	2024/05/09 03:15	Project Meeting	Sam Smith [s...]	Meeting room 1		Arranged			
15462	04:30	2024/05/09 04:30	2024/05/09 04:45	Project Meeting	Sam Smith [s...]	Meeting room 1		New			
15420	05:00	2024/05/09 05:00	2024/05/09 05:15	Project Meeting	Sam Smith [s...]	Meeting room 1					
15427	05:45	2024/05/09 05:45	2024/05/09 06:00	Board Meeting	Mark Olin [m...]	Meeting room 2		New			
15431	06:45	2024/05/09 06:45	2024/05/09 07:00	Internal Meeting	Jane Alison [j...]	Meeting room 3		New			
15354	07:15	Meeting is cancelled	2024/05/09 07:30	Board Meeting	Mark Olin [m...]	Meeting room 2		Arranged			
15373	07:30	2024/05/09 07:30	2024/05/09 07:45	Internal Meeting	Jane Alison [j...]	Meeting room 3		New			
15438	08:00	2024/05/09 08:00	2024/05/09 08:15	Client Meeting	Jane Alison [j...]	Meeting room 4		Changed			
15383	09:00	2024/05/09 09:00	2024/05/09 09:15	Board Meeting	Mark Olin [m...]	Meeting room 2		New			
15387	12:30	2024/05/09 12:30	2024/05/09 12:45	Internal Meeting	Jane Alison [j...]	Meeting room 3		New			
15481	13:00	2024/05/09 13:00	2024/05/09 13:30	Client Meeting	Jane Alison [j...]	Meeting room 4		New			
15483	19:00	2024/05/09 19:00	2024/05/10 19:00	Internal Meeting	Jane Alison [j...]	Meeting room 3		New			

Figure 128. List of Orders

If the current logged in user has been set up to allow **“View all messages”** in his/her respective role, a list of persons having orders in the selected month is shown in **“Persons with Orders”**. The dates within the month holding orders (if any) are bold on Calendar. User without **“View all messages”** right can view only his/her orders in the system and cannot see **“Persons with Orders”** list.

If you want to see any specific person’s message view, click on the person’s name in **“Persons with Orders”** list box and see the orders shown to the selected user. You can also search for a specific order by clicking a Group in **“Resources by Group”** list box, the orders with selected resource group will be displayed.

The Replies section at the top of an order’s details will only be available if any of the Service Provider(s) has sent a reply(s) corresponding to his/her associated order. Also, the Logged in person can only view the replies of those person(s) who have the same role(s) as that of the Logged in person. Otherwise, the Logged in person will never see the replies of those person(s) whose role(s) is different than that of the logged in person.

Order - 15394

LIST PRINT UPDATE UPDATE AND SEND EMAIL RESOURCE LOCATION SEND TAX RECEIPT VIEW LATEST TAX RECEIPT VIEW TAX RECEIPT HISTORY

Order number 15394

From: 2024/05/09 03:00 (Thursday)
 To: 2024/05/09 03:15 (Thursday)
 Subject: Project Meeting
 Organizer: Sam Smith [samsmith@rcaod.onmicrosoft.com]
 Assistant organizer: Peter Smith[petersmith@rcaod.onmicrosoft.com]
 Resource: Meeting room 1

^ Replies

Date	Person	Message
2024/05/03 11:27	Person 1	Message 1
2024/05/03 11:54	Person 2	Message 2
2024/05/03 11:57	Person 3	Message 3

Figure 129. Replies section in Order details

In case there are orders that only have items & properties of 'Informative' type, you can check on the **Informative Only** option to mark color to all of those orders. E.g.:

+ NEW PRINT PRINT ALL Per Order INFORMATION ONLY SET ORDER STATUS Select a Status DECLINE ACCEPT SEND TAX RECEIPT

Order No.	Delivery	Reservation at	Ends at	Subject	Q...	Pers...	Order status	Tax Receipt
15763	11:30	28.October.2022 11:30	28.October.2022 12:00	sign2	T...	H.	New	

+ NEW PRINT PRINT ALL Per Order INFORMATION ONLY SET ORDER STATUS Select a Status DECLINE ACCEPT SEND TAX RECEIPT

Order No.	Delivery	Reservation at	Ends at	Subject	Q...	Pers...	Order status	Tax Receipt
15763	11:30	28.October.2022 11:30	28.October.2022 12:00	sign2	T...	H.	New	

Figure 130. Color mark when Informative Only box is checked.

The color mark is determined by the **Informative Order** color which can be customized in **Designer → Orders**.

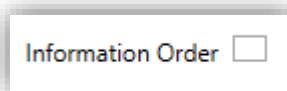

Accept

Selecting a given order, you can click [**Accept**] (on toolbar) which opens 'Order feedback' form:

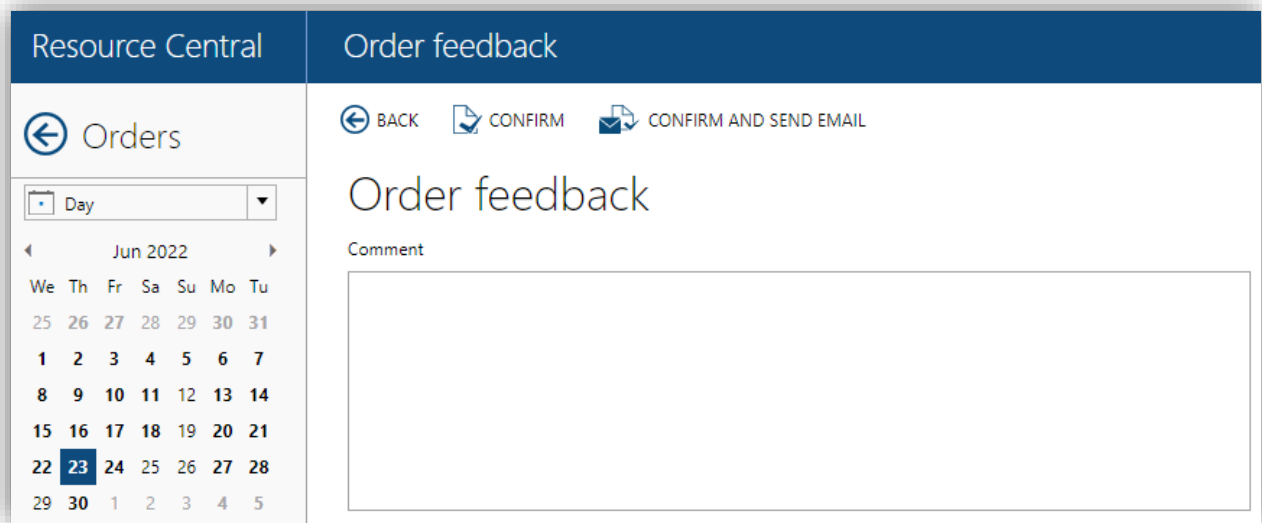

Figure 131. Order feedback

Here you can give comment, then either:

- Click [**Confirm**] to finally accept the order, but no email will be sent.
- Click [**Confirm and send email**] to finally accept the order, and produce a **confirmation message** sent to the organizer, with your comments (if any) in the form of an email.

As you accepted the order, the status of all the Item(s) is set to **Confirmed** and the **Accept** button will be removed from the toolbar.

Decline

Selecting a given order, you can click [**Decline**] which also opens 'Order feedback' form as figure above.

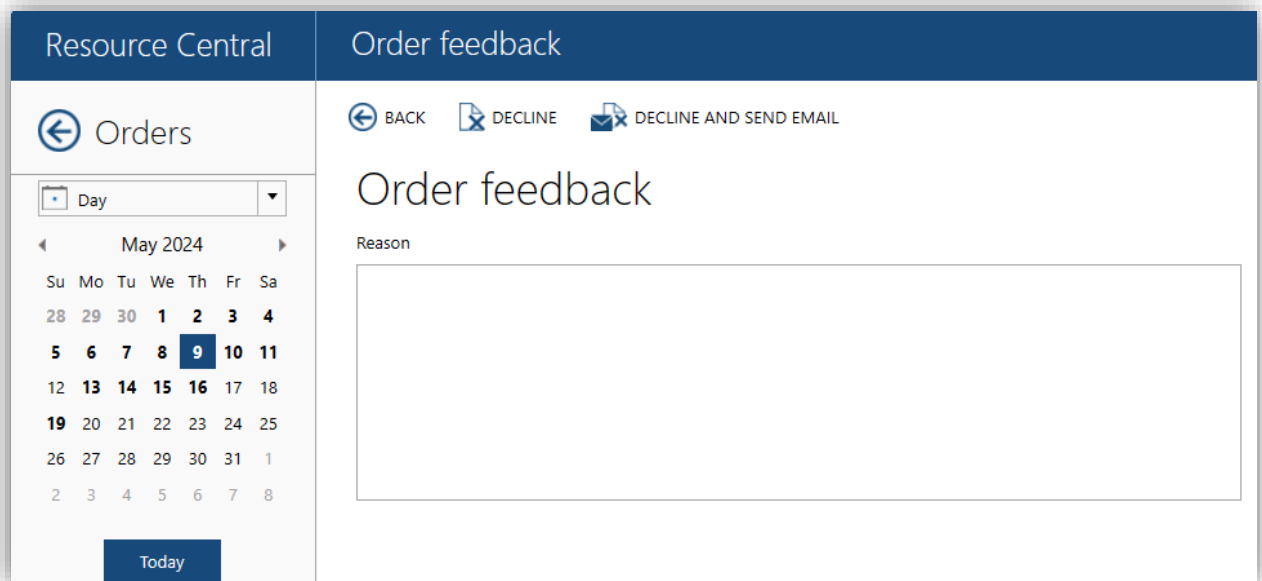

Similarly, you can give comment, then either:

- Click [**Decline**] to finally decline the order, but no email will be sent.

- Click [**Decline and send email**] to finally decline the order, and send notification email to the organizer.

As you declined the order, the status of all the Item(s) is set to **Declined** and the **Accept & Decline** buttons will be removed from the toolbar.

Clicking either [**Accept**] or [**Decline**], the comment from 'Order feedback' form will be shown in "**Replied**" section of the email sent to organizer.

Send email when order status changes

When you change status for selected orders, you can choose to send notification email to organizer or not.

As you set a status for selected orders, the following message will appear:

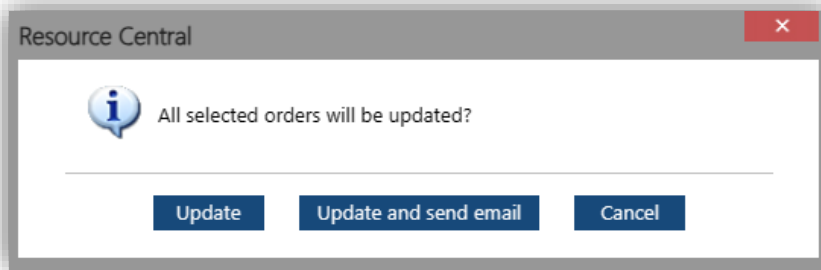

Figure 132. Confirmation message when change Order status

You can select one of 3 choices:

- [**Update**]: update new status for all selected orders, but no email will be sent.
- [**Update and send email**]: update new status for all selected orders and send notification email to the organizer.
- [**Cancel**]: cancel this decision and close this message.

Print the order

If you click [**Print**], details of the selected orders are shown in a new window as shown below:

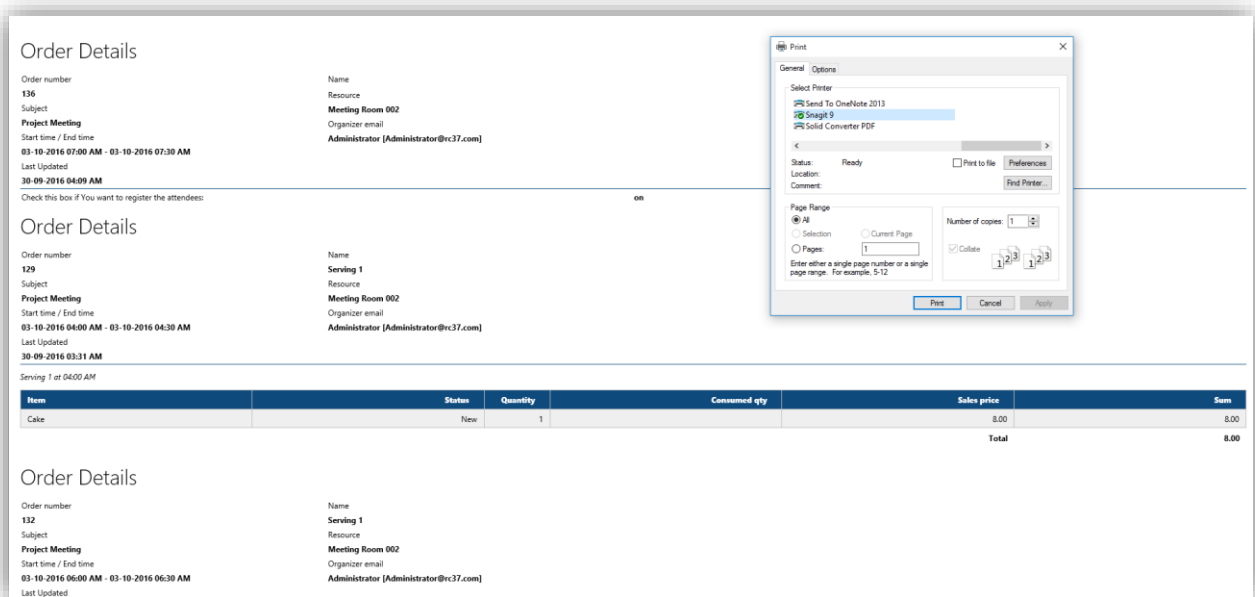
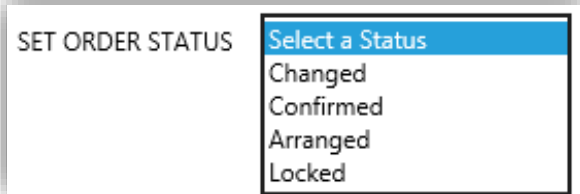

Figure 133. New window displaying order details

You can utilize the drop-down list on the toolbar to set order status as you wish.



In each column, there is an arrow next to the column name to help you filter data in that column. Clicking on the arrow will show corresponding filter options:

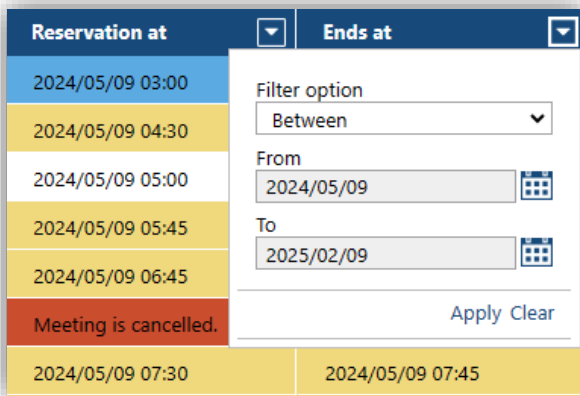
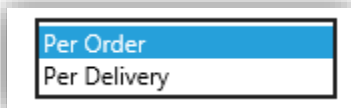

Figure 134. Ends at – Filter options

On the toolbar, there is another dropdown list for printing options:



Printing option	Description
Per Order	The details of the whole selected order are printed
Per Delivery	The details of the selected serving of an order are printed

If you click [**Print**], details of the selected orders are shown in a new window dependent on the selected printing options:

Order number 2263

From: 13.12.2016 11:00 (Tuesday)
 To: 13.12.2016 11:30 (Tuesday)
 Subject: Project Meeting
 Organizer: John Smith [js@aoc.com]
 Resource: Meeting Room 201

Replies

^Date	Person
13.12.2016 09:00	Maria Lopez
13.12.2016 09:01	Maria Lopez
13.12.2016 09:06	Maria Lopez

Order details

Serving 1 at 11:00

^Name	Qty	Consumed Qty	Quota	Sales price
Cake	3		96	0,00
Coffee	2		96	5,50
Total				

Serving 2 at 11:00

^Name	Qty	Consumed Qty	Quota	Sales price
Tea	2		98	15,50
Mineral Water	2		3240	5,50

Figure 135. Print – Per Order

Order Details

Order number: 2263
 Subject: Project Meeting
 Start time / End time: 13.12.2016 11:00 - 13.12.2016 11:30
 Last Updated: 13.12.2016 09:10

Name: Serving 1
 Resource: Meeting Room 201
 Organizer email: js [js@aoc.com]

Check this box if you want to register the attendees: on
 Number of parties involved: 3
 Number of companies present: 2

Serving 1 at 11:00

^Item	Status	Quantity	Consumed qty
Cake	New	3	
Coffee	Confirmed	2	

5:50 Total 11:00

Print dialog box:

General Options
 Select Printer: Snagit 9, Solid Converter PDF
 Status: Ready
 Location:
 Comment:
 Page Range: All
 Number of copies: 1
 Print button visible.

Figure 136. Print – Per Delivery

To have a brief review of the order, you can click on the (+) icon on the left of an Order No., summary details of that order will be displayed:

Order No.	Delivery
15394 (+)	03:00
15462 (+)	04:30

Figure 137. See summary of the order

Clicking one of the orders will show **order details as per Serving**. You will also be able to see the **current status** of all the individual items in the order.

The order detail view is also role based. That is, the logged in person will only see his/her items and properties. All the other items and properties will not be shown to the logged in person.

Order - 2263 Host (Security)

LIST PRINT

Order number 2263

From: 13.12.2016 11:00 (Tuesday)
To: 13.12.2016 11:30 (Tuesday)
Subject: Project Meeting
Organizer: John Smith [j@aac.com]
Resource: Meeting Room 201

Replies

Date	Person	Message
13.12.2016 09:00	Maria Lopez	
13.12.2016 09:01	Maria Lopez	
13.12.2016 09:06	Maria Lopez	

Order details Set all [v] Collapse All

Serving 1 at 11:00

Name	Qty	Consumed Qty	Quota	Sales price	Sum	Status	Description
Cake	3		96	0.00	0.00	New	
Coffee	2		96	5.50	11.00	Confirmed	
Total					11.00		

Add

Figure 138. Order details per serving

NOTE: If you click [Print All] button, all orders for the selected date (not only the orders displayed on the screen) will be printed. The maximum number of orders to be printed is controlled by the parameter **MaxOrderList.PrintAll**. For more information about this parameter, please refer to **RC Parameter Guide**.

Set up the catering staff

In the order details, there are three fields for you to configure catering staff:

Order details Set all [v]

If you require extra services for your resource booking, please enter the number of deliveries, and fill out this form.

Number of deliveries: 1 Delivery [v]
1st service: Serving 1 03:30 [v]

Serving 1 at 03:30

Setup services: John Smith Jame, Semi [...] During services: Duncan Cunningham [...] Cleanup services: Katy O'Brien, Julia O'Brien [...]

Name	Qty	Consumed Qty	Quota	Sales price	Sum	Status	Description
Coffee & Tea_Testing	4	4	93	12.00	48.00	Changed	
Total					48.00		

Add

Figure 139. Configure catering staff

Click on the [...] button to select suitable catering staff. These staff names are taken from Active Directory using RTS calendar API.

The availability of these fields (**Setup services**, **During services** and **Cleanup services**) is controlled by the parameter **Orders.ShowCateringStaff**. Refer to **RC Parameter Guide** for more details.

Reservations

This screen shows all **reservations** of the current **selected date**. When it is opened for the first time, the current system date will be selected.

The reservations corresponding to selected group under '**Group**' section can be accessed by selecting the respective highlighted date of calendar. User will see '**Default**' group in Group list when no group is created in the system.

NOTE: Designer → Resources node has been made role-based, as per the Location(s) of the logged in person. That is, you can only view those Resource (s) that belong to your Absolute Location(s) or Children Location(s). Also, you can only create/update Resource(s) at your Location(s).

The Reservations Tree Node has been also made role-based, as per the Location(s) of the Logged in person. That is, you can only view the reservations of those Resource(s) which belong to the same Location as that of your Absolute Location(s) or Children Location(s).

Resource Central Reservations - Friday, September-18-2020

PRINT RESOURCE TYPE ACTIVE RESERVATIONS DELETED RESERVATIONS

From	To	Resource	Subject	Organizer	Is Recurring	Location
03:00 AM	03:30 AM	Meeting Room 002	Campaign Launch	Administrator@rc37.com (Administrator)	✓	Locations
04:00 AM	04:30 AM	Meeting Room 002	Project Meeting	Administrator@rc37.com (Administrator)		Locations
06:00 AM	06:30 AM	Meeting Room 002	Project Meeting	Administrator@rc37.com (Administrator)	✓	Locations
07:00 AM	07:30 AM	Meeting Room 002	Project Meeting	Administrator@rc37.com (Administrator)		Locations
08:30 AM	09:00 AM	Meeting Room 002	Press Conference	Administrator@rc37.com (Administrator)		Locations

Figure 140. List of Reservations

As you can see in the highlighted area in the above figure, “Is Recurring” head shows whether the listed reservation is a recurring reservation or not.

Clicking one of the reservations will show details about it.

Reservation details

Viewing a given reservation, you will be presented with the following information:

Reservation Project Meeting

LIST | ORDER FORM | ORDER STATUS | MAIL LOG | HISTORY

Reservation Details

Resource
Meeting Room 002

Active
True

Start time
03-10-2016 06:00 AM (Monday)

End time
03-10-2016 06:30 AM (Monday)

MEETING ROOM 002

SHARED ORDER FORM

Reservation of Meeting Room 002

From	Subject
03-10-2016 06:00 AM	Project Meeting
To	Description
03-10-2016 06:30 AM Romance Standard Time	
Location	Capacity
Locations	10

Minimum Hours - Latest deadline for when a Resource Central order can be created
0

Meeting Room 002 Order

If you require extra services for your resource booking, please enter the number of deliveries, and fill out this form.

Number of deliveries:

1st service:

Serving 1

Name	Price	Qty
Cake	8.00	1
Coffee	5.00	
Tea	8.00	
Catering Total		8.00

Attendees

Register attendees

Title	* Name	E-mail
<input type="text"/>	<input type="text"/>	<input type="text"/>

[Details](#) | [Remove](#)

Extra services for your meeting

Account Number

Figure 141. Reservation Details

Field	Description
Resource	Name of the resource
Start Time	Start date and time of the reservation
End Time	End date and time of the reservation
Active	The value TRUE is active, FALSE is not active. These values correspond to the FREE/BUSY/TENTATIVE value of the Exchange item

Toolbar Buttons	Description
Back	Go back to the previous screen view
Order Form	Displays order form in the lower right pane
Order Status	Displays order status form in the lower right pane
Mail Log	Displays all the emails that have been sent for the current reservation
History	Display all tracking data for this reservation

Clicking **Order Form** on the toolbar would display the **Order Form** (if it exists) in the **bottom right pane** of the application screen. If you click “**Send Order**” after changing any information on the order form, the emails will be sent to the organizer and the Service Providers, and the normal flow of the application would run.

Also, the “**Send order**” button at the Order Form of the Reservation Details screen will only be Enabled if any of the roles assigned to the logged in person has “**Role can edit order = Yes**”. If all of the roles assigned to the logged in person have “**Role can edit order = No**”, then the “**Send order**” button will be Disabled, thus prevents the logged in person from making any changes to the Order associated with the reservation.

Clicking upon [**Order Status**] on the toolbar will display the **Order Status Form** (if it exists) in the lower right pane of the application screen.

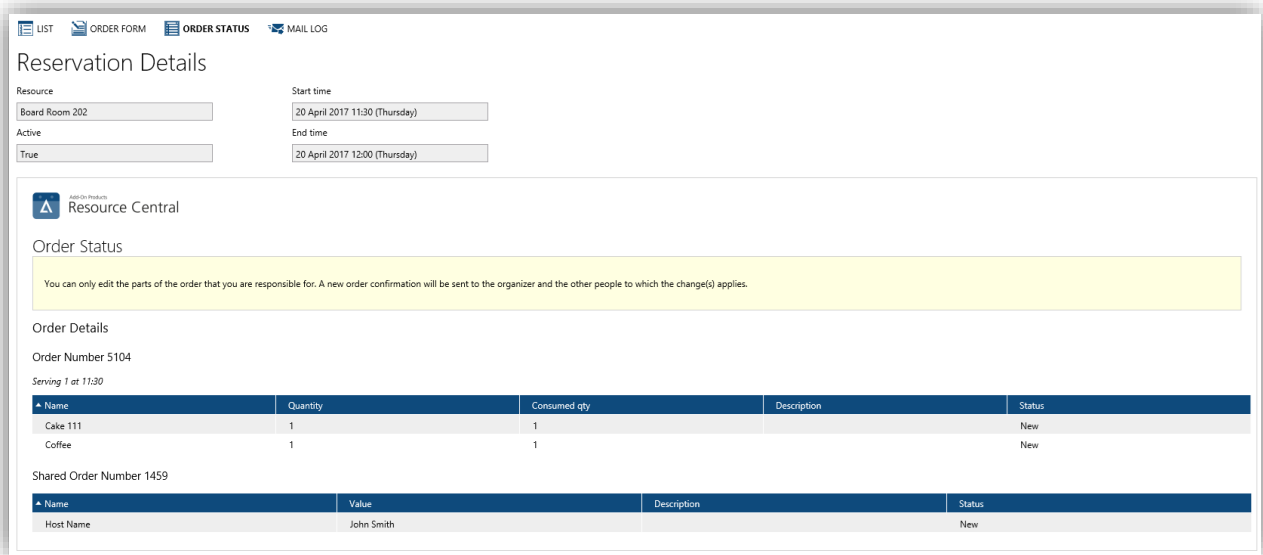

Figure 142. Reservation: Order Status Form

Clicking upon **Mail Log** on the toolbar would display all the emails that have been sent for the current reservation. Selecting an **email(s)** (by checking the checkbox) and clicking [**Resend**] would resend the selected mails to its recipient as mentioned in the “**To**” field.

Mails - Tuesday, 23-05-2017				Host (Security)	⏻
⏪	BACK	✉	RESEND		
☐	▲ Sent	Subject	To	From	
☐	30-09-2016 03:31 AM	New Order on 03-10-2016 04:00 AM at Locations\Europe\Germany	Administrator@rc37.com	resource2@rc37.com	

Figure 143. Reservation: Mail Log – List of all the emails sent for the reservation

Clicking upon **History** on the toolbar will display all the historical data for the current reservation. The history is fetched and generated on demand and is not stored.

Change Type	Changed time	Changed by	Changed from	Subject	Start time	End time	Resource	Busy status	Sync status
☐ Created	May/06/2021 09:38	chi_org@aoprc.onmicrosoft.c...		Project Meeting	May/11/2021 11:00	May/11/2021 11:30			✓
Exchange:									
Created	May/06/2021 09:38	chi_org@aoprc.onmicrosoft...		Project Meeting	May/11/2021 11:00	May/11/2021 11:30	Hot Desk-Chi_Resyn2-HN	BUSY (Accepted)	
Resource Central:									
Attendees: chi_org@aoprc.onmicrosoft.com									
+	Created	May/06/2021 09:38		Project Meeting	May/11/2021 11:00	May/11/2021 11:30	Hot Desk-Chi_Resyn2-HN	BUSY	✓
☐ Changed	May/06/2021 09:51			Project Meeting	May/11/2021 11:00	May/11/2021 11:30			✗
Exchange:									
Resources: Hot Desk - Chi_Resyn10 HotDesk-Chi_Resyn2-HN									
Created	May/06/2021 09:40	chi_org@aoprc.onmicrosoft...		Project Meeting	May/11/2021 11:00	May/11/2021 11:30	Hot Desk - Chi_Resyn10	BUSY (Accepted)	
Deleted	May/06/2021 09:51	chi_org@aoprc.onmicrosoft...		Project Meeting	May/11/2021 11:00	May/11/2021 11:30	Hot Desk-Chi_Resyn2-HN	BUSY (Accepted)	
Resource Central:									
Attendees: chi_org@aoprc.onmicrosoft.com, joe_mount@aoc.com									
+	Created	May/06/2021 09:40	Booking Manager	Project Meeting	May/11/2021 11:00	May/11/2021 11:30	Hot Desk - Chi_Resyn10	BUSY	✓
Attendees: chi_org@aoprc.onmicrosoft.com, joe_mount@aoc.com									
+	Deleted	May/06/2021 09:41	Booking Manager	Project Meeting	May/11/2021 11:00	May/11/2021 11:30	Hot Desk-Chi_Resyn2-HN	DELETED	✓

Figure 144. History

This History feature enables the administrator to keep track of all changes made to the selected reservation (in terms of resources, date/time, subject, attendees, and mail notifications). The history will focus on the Exchange meeting, so it can contain multiple resource reservations.

Click on '+' symbol to expand data tracked for this reservation.

Change Type	Changed time	Changed by	Changed from	Subject	Start time	End time	Resource	Busy status	Sync status
☐ Created	May/06/2021 09:38	chi_org@aoprc.onmicrosoft.c...		Project Meeting	May/11/2021 11:00	May/11/2021 11:30			✓
Exchange:									
Created	May/06/2021 09:38	chi_org@aoprc.onmicrosoft...		Project Meeting	May/11/2021 11:00	May/11/2021 11:30	Hot Desk-Chi_Resyn2-HN	BUSY (Accepted)	
Resource Central:									
Attendees: chi_org@aoprc.onmicrosoft.com									
☐ Created	May/06/2021 09:38			Project Meeting	May/11/2021 11:00	May/11/2021 11:30	Hot Desk-Chi_Resyn2-HN	BUSY	✓
Notifications:									
1. New Reservation to chi_org@aoprc.onmicrosoft.com									
2. New Reservation to chi_sda@aoprc.onmicrosoft.com									
☐ Changed	May/06/2021 09:51			Project Meeting	May/11/2021 11:00	May/11/2021 11:30			✗
Exchange:									
Resources: Hot Desk - Chi_Resyn10 HotDesk-Chi_Resyn2-HN									
Created	May/06/2021 09:40	chi_org@aoprc.onmicrosoft...		Project Meeting	May/11/2021 11:00	May/11/2021 11:30	Hot Desk - Chi_Resyn10	BUSY (Accepted)	
Deleted	May/06/2021 09:51	chi_org@aoprc.onmicrosoft...		Project Meeting	May/11/2021 11:00	May/11/2021 11:30	Hot Desk-Chi_Resyn2-HN	BUSY (Accepted)	
Resource Central:									
Attendees: chi_org@aoprc.onmicrosoft.com, joe_mount@aoc.com									
+	Created	May/06/2021 09:40	Booking Manager	Project Meeting	May/11/2021 11:00	May/11/2021 11:30	Hot Desk - Chi_Resyn10	BUSY	✓
Notifications:									
1. New Reservation to chi_org@aoprc.onmicrosoft.com									
Attendees: chi_org@aoprc.onmicrosoft.com, joe_mount@aoc.com									
☐ Deleted	May/06/2021 09:41		Booking Manager	Project Meeting	May/11/2021 11:00	May/11/2021 11:30	Hot Desk-Chi_Resyn2-HN	DELETED	✓
Notifications:									
1. Cancelled Reservation to chi_org@aoprc.onmicrosoft.com									
2. Cancelled Reservation to chi_sda@aoprc.onmicrosoft.com									

Figure 145. Detailed history

For each change type, the content is divided into 2 sections: Exchange and Resource Central.

Details in the Exchange section show what happened to the reservation based on the Exchange History of the meeting, and details in Resource Central section shows what Resource Central has done in responds to the Meeting. You can have a look at the following table for detailed information on each column:

Column	Description
Change Type	Show what type of change is made to the reservation. It is either Created, Changed or Deleted.
Changed time	Show when the change is made to the reservation.
Changed by	Show who made the change. It might be organizer, the Exchange delegate, or the Auto Accept Agent (as a response to the delegate's action).
Changed from	Show where the change is made. It is either Booking Manager or Full Sync. Full Sync is initiated in Realtime Service and will adjust all Resource Central reservations that are not correctly aligned with the resource calendars in Exchange.
Subject	Show the subject of the reservation when each change is made.
Start time	Show the start time of the reservation when each change is made.
End time	Show end time of the reservation when each change is made.
Resource	Show resource(s) related to the reservation when each change is made.
Busy status	Show the reservation status. For example, the status BUSY (Accepted) includes: <ul style="list-style-type: none"> - BUSY: The meeting's BusyStatus chosen by the Organizer - Accepted: Response type sent by Resource's calendar to organizer <p>NOTE: If impersonation rights are not established for the users, those updates which have not been recorded by RealTime Service will not be displayed.</p>
Synch status	Show synchronization status between Resource Central and Exchange. Was Resource Central not able to get all details from Exchange or if Resource Central failed to create the right notifications due to system error the resynch button can be pressed, and the errors are corrected. Missing notifications on still relevant changes will be sent.

NOTE:

1. The feature only shows changes related to the reservation/meeting details, so no changes made only in relation to the order will be shown for now. E.g., organizer changing the order from ResourceFinder or MyMeeting.
2. Exchange removes history on declined/deleted appointments after 14 days and removes general history after 120 days. Therefore, the history of this appointment might not reflect the correct history of the Exchange appointment.
3. For full feature functionality Impersonation Right on users and Remote PowerShell are required on the service account. The history feature can be used without it, but will have the following limitations:
 - a. Lack of Impersonation Rights
 - i. Full appointment history might not be retrievable when the organizer removes all resources during a system down period and later adds a new resource, then the system will not show the removal of the resources, but end result with the added the new resource.
 - ii. Load time of history will be slower.

- b. Lack of Remote PowerShell - Name of delegate will not be available in the “Change by”-column. Only “Delegate” is shown

Overview

The overview screen shows you the booking status of the available resources at the currently selected date. When opening the screen, the current system date will be selected by default.

You can **filter** the reservation view by resource group which are listed under ‘**Group**’ section. The highlighted dates within the selected month of the calendar are those that have reservations. The time interval shown in this screen can be configured through **Basic System Parameters** at Resource Central manager site.

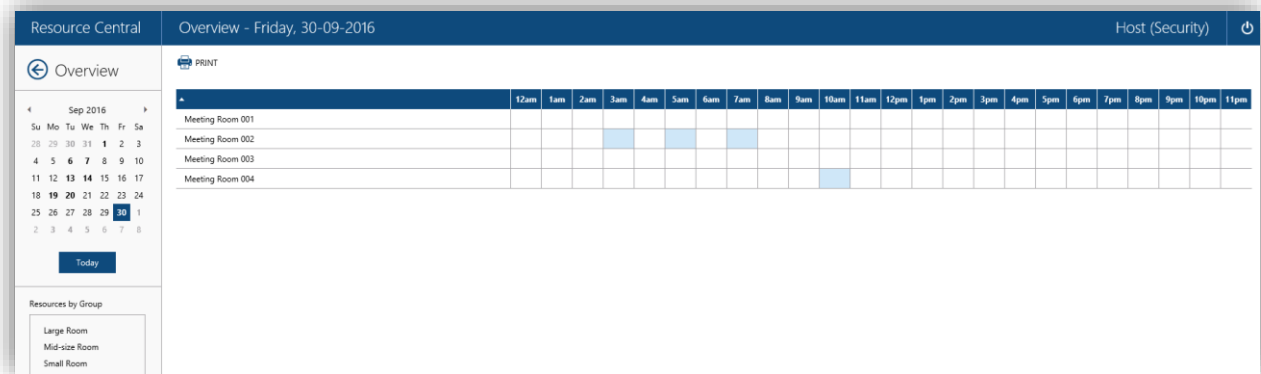

Figure 146. Overview of the Reservations

Booking Manager

Refer to **Booking Manager User Guide** document for more details.

Items

Items section contain a record for every item that can be ordered.

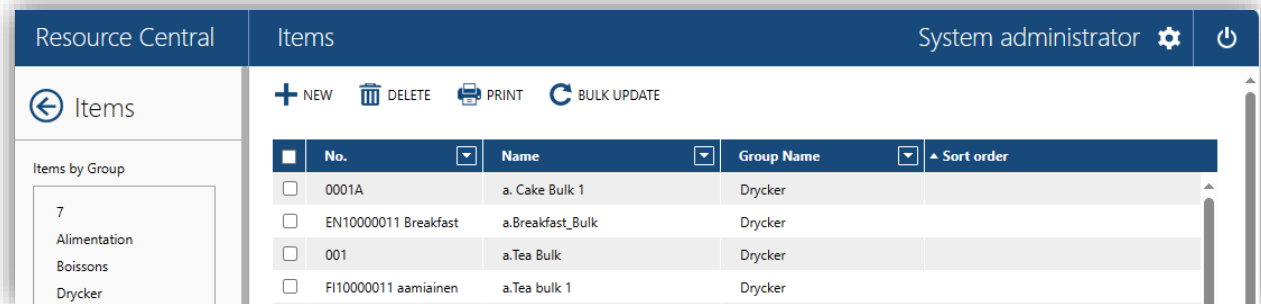

Figure 147. List of all Items

NOTE: **Daily Tasks** → **Items** node has been made role-based, as per the Location(s) of the logged in person. That is, you can only view those Item(s) which belong to your Absolute Location(s) and/or Children Location(s). Also, you can only create/update Item(s) at your Location(s). If you try to create/update an Item to such a location that is not the Absolute Location or the Children Location of the Logged in Person, the system will not allow you to do so and a proper warning message will be displayed, as shown below:

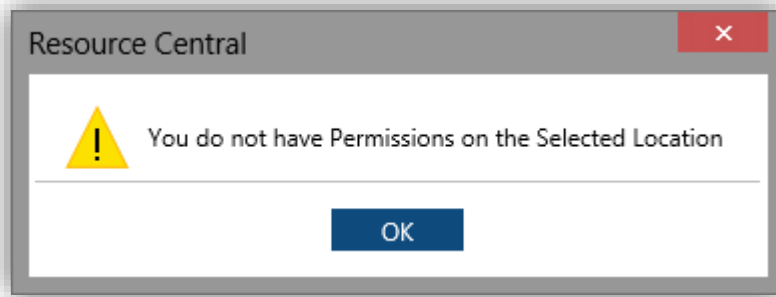

Figure 148. Warning message – Permission of Locations

Toolbar Buttons	Description
New	You can add a new item
Delete	You can delete the selected items
Print	Print all item(s)
Bulk update	Update multiple items simultaneously

Delete item:

- The value of parameter **Delete.Item** is **0**: You cannot delete any item which is served in an order.
- The value of parameter **Delete.Item** is **1**: You can delete any item which is served. When you delete an item, you can still see it in old order but cannot see it any more in Items or new serving. It is also impossible to see the deleted item in old order when user changes quantity or edit the serving. See the Parameter section for details.

You can **filter** the Items by selecting a group from “**Group**” List box. To remove the **Group Filtering**, you have to click the same group again in the **Group** List box.

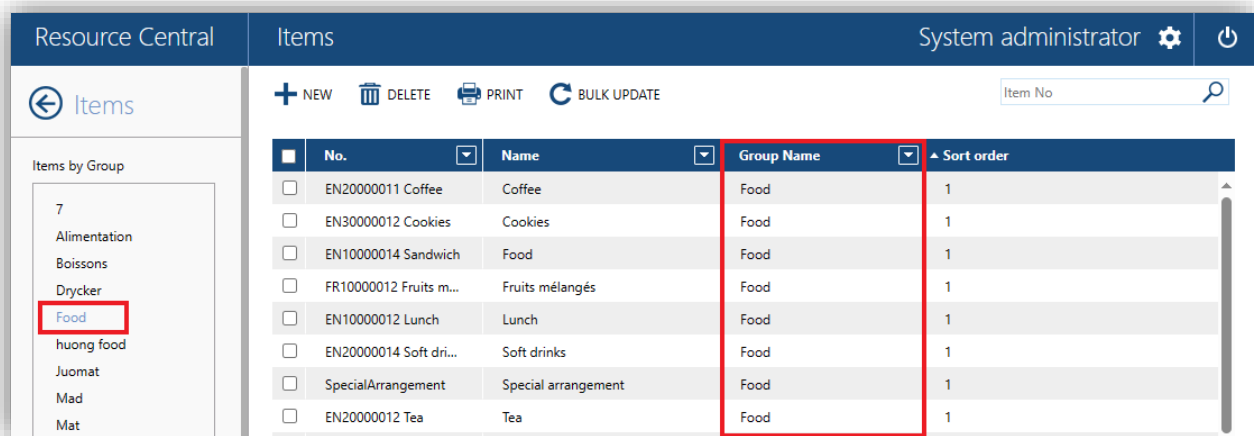

Figure 149. List of all the Items belonging to the selected Group

Clicking one of the items will show details about it.

Item details

From the item **detail view**, you can edit and save the record.

LIST
SAVE
RESOURCE
SAVE CONFIGURATION
NUTRITION INFORMATION
ASSIGNMENTS

Item Details

*** ID**

*** Location**

*** Group name**

*** Roles**

admin
Host(Security Role)

Sort order

*** Quota**

Quantity threshold

Can be added by

Image for Service Provider

Image for Order form

Name

Sales price including VAT

Sales price (external)

Cost price

VAT %

Extra Id 1

Extra Id 2

Description

Menu item only

Editable pricing

Editable name

Availability

Start time

End time

Active weekdays

Mon Tue Wed Thu Fri Sat Sun

Start date

End date

No end date

Available for

Internal External

Deadlines

Deadline for the item

Workdays before deadline

Time

Extended Item Deadline

Workdays before extended deadline

Time

Figure 150. Details of an Item



Field	Description
ITEM DETAILS	
ID	A code for identifying the record.
Name	The text presented to the meeting organizer when being asked for this item.
Location	Select the location of item (mandatory) The location must be defined in ' Locations ' tree under Location node.
Sales price including VAT	Sales price is the price of the item. A value 0 indicates that no calculation should be made.
Group Name	Group Name can be used for categorizing the items.
Cost Price	Cost price of the item. A value 0 indicates that no calculation should be made.
Roles	Roles that link to this item.
VAT %	Percentage of VAT.
Extra ID 1 and 2	Fill in alphanumeric data. These two fields serve retrieving results for a custom report
Sort Order	Sort order can hold any alphanumeric values and are used for sorting items.
Quantity threshold	A threshold when ordering items above a certain quantity. If the item's ordered quantity reaches the specified threshold, the order can trigger e.g., a customizable warning to the organizer, have an extended deadline and be marked in The Order Overview. For more details refer to Quantity threshold .
Description	A short description of the item.
Can be added by	Select the person(s) who can add this item
Image for Service Provider	Select image to be used in customized reports for Service Provider
Image for Order Form	Select image to be used in the order form
Menu item only	Check on this to prevent organizer from booking the current item as a single item. It must be booked along with the menu to which it belongs.
Editable pricing	It allows that items can be configured to have an editable Sales price. When configured the service provider can manually change the item price via RC backend → Orders or Service Provider's email . NOTE: This option is only available if the value of parameter Enable.EditableItem is '1'. Refer to Parameter Guide for more details.
Editable name	It allows that items can be configured to have an editable name. When configured the service provider can manually change the item name via RC backend → Orders or Service Provider's email . The edited name will only be applied in that order only. NOTE: This option is only available if the value of parameter Enable.EditableItem is '1'. Refer to Parameter Guide for more details.

The maximum number of items could be ordered a day. For detailed information on this feature, refer to the **Canceling Resource Reservation** on Reminder Email
Reminder Email also provides the ability to cancel resource reservation for a meeting. It only removes the designated resource from Resource Calendar; however, its respective meeting will remain in Organizer Calendar.

To do this, open the Reminder Email and you will see the following choice:

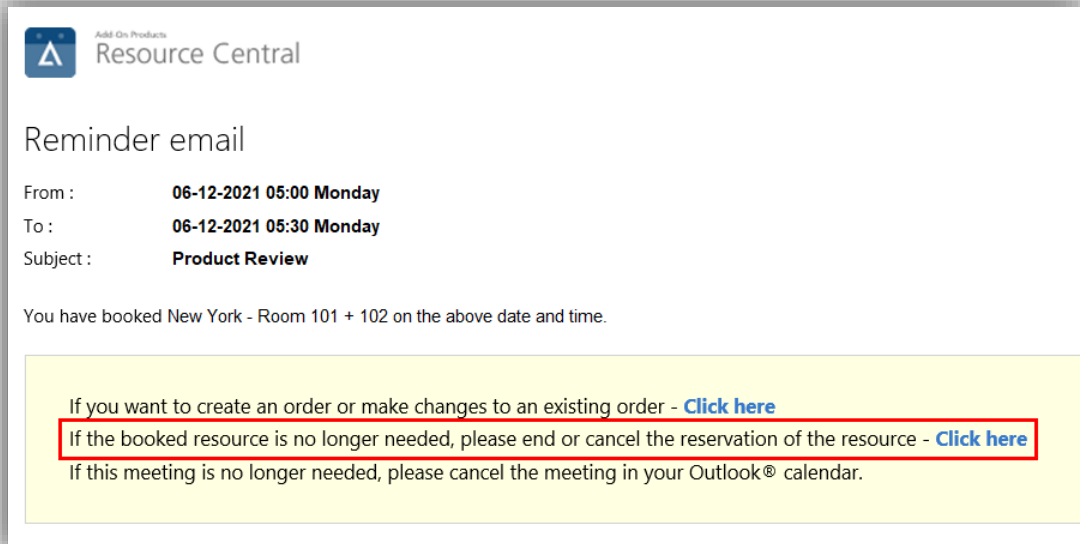

Quota

You will see the Cancel Reservation page, then you can click [**Cancel Reservation**] to confirm:

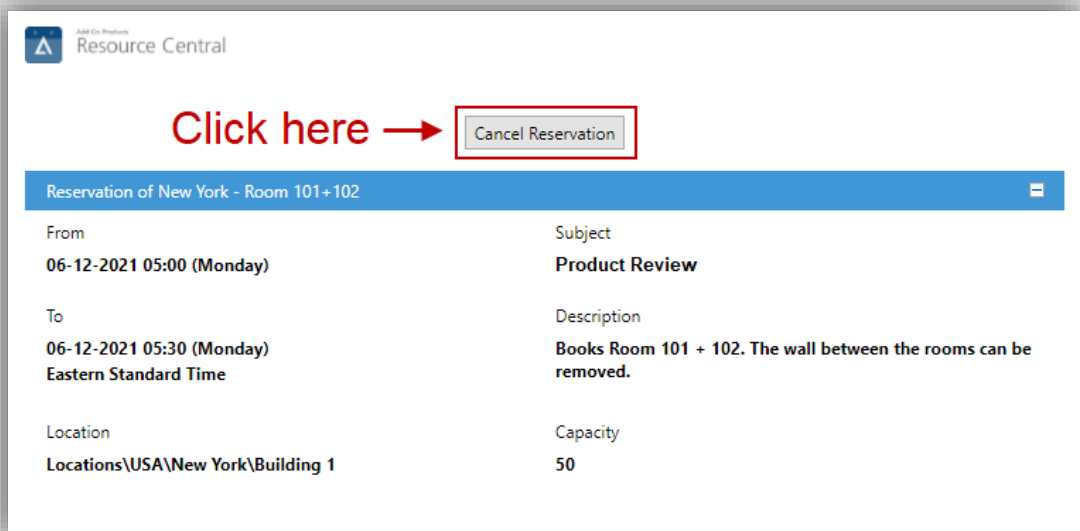

Finally, a notification page will appear confirming the cancellation.

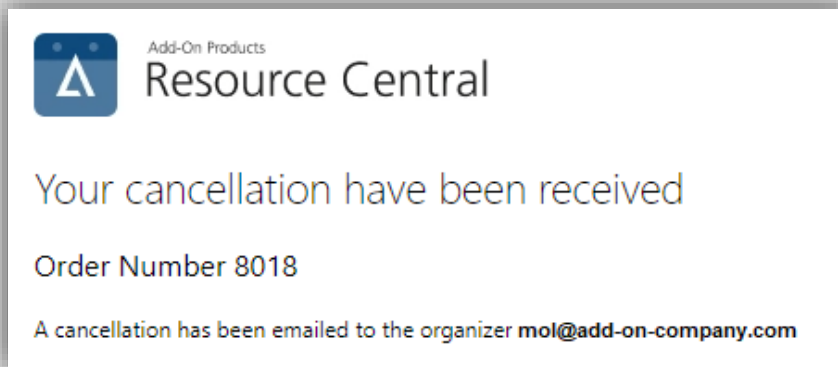

NOTE: When you cancel a resource reservation, that resource will be bookable at the cancelled time.

Item Quota Functionality section in this guide.

AVAILABILITY	
Start date & End date	Time range established to define availability period of the item
Start time & End time	
Active weekdays	
No end date	Check this option to NOT have the end date, meaning the item is always available starting from the start date.
DEADLINES	
Deadline for the item	Enable deadline for booking the current item.
Workdays before deadline & Time	Time range established to define deadline to book the item.
Extended Deadline for the item	Enable extended deadline for booking the current item. It is applied when the item's ordered quantity reaches The Quantity Threshold
Workdays before extended deadline & Time	Time range established to define extended deadline to book the item.

Toolbar buttons	Description
Save	Saves the information edited in the Input fields
Resource	Displays the list of resources with which the item is associated (see details below)
List	Displays the list of Items

Save Configurations	The values in all of the fields will be saved so that the next time when the user clicks NEW to create a new item, all of the fields will be pre-populated with those saved values. (Value in the 'Name' field will not be saved).
Nutrition Information	Add nutrition information to the item
Assignments	View the list of all Persons with Assignable roles or Informative roles given to this item.

Sales price and Cost price

- The value of parameter **Item.Price** is **0** or parameter is not created: If you change the price, this will have an impact on all items even if they have been ordered for delivery in the future and all reports for the sales that have already been delivered.
- The value of parameter **Item.Price** is **1**: Change in item prices could be validated against the dates. Ordered items would not be affected by changes in prices.

Whenever a user books an item, the item's price at that time is saved. Therefore this "validating against date" feature is applied only for price of the item ordered after value of **Item.Price** parameter is specified as 1. The price of the item which has been reserved before will be changed when the administrator changes the item's price.

Further details of this parameter can be read in the **Resource Central Parameter Guide**.

Item availability

If you change anything in Availability section of the item's details, the following window shows up:

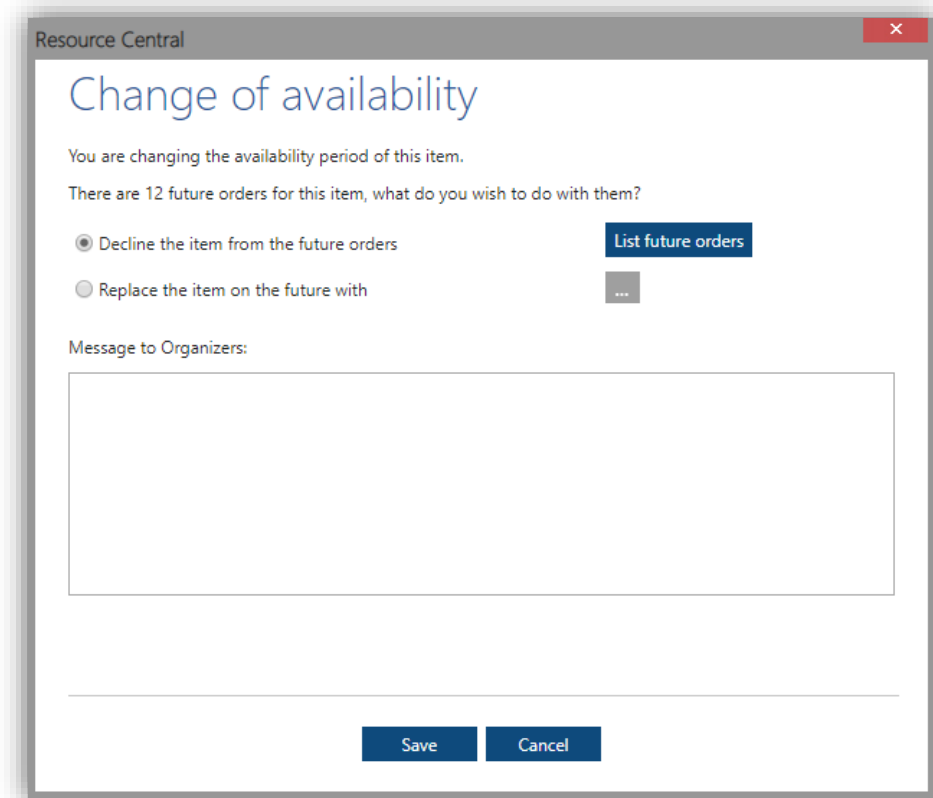

Figure 151. Change of item availability

In this window you can decide what to do with the affected orders and send a message to organizers about the changes.

Item: Resource

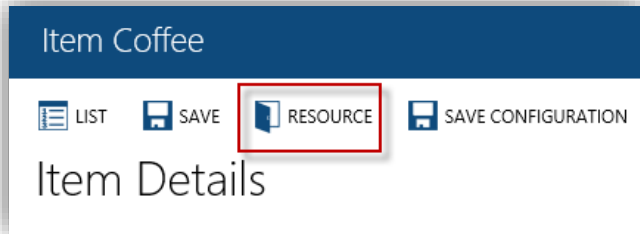

Figure 152. Resource Button

Clicking “**Resource**” at the toolbar on the right pane of the application screen, all the resources related to the selected item are displayed. You can use the toolbar buttons to create & remove association of the current item with the resources.

Please note that Item Resource Association screen is also role-based, as per the Location (s) of the logged in person.

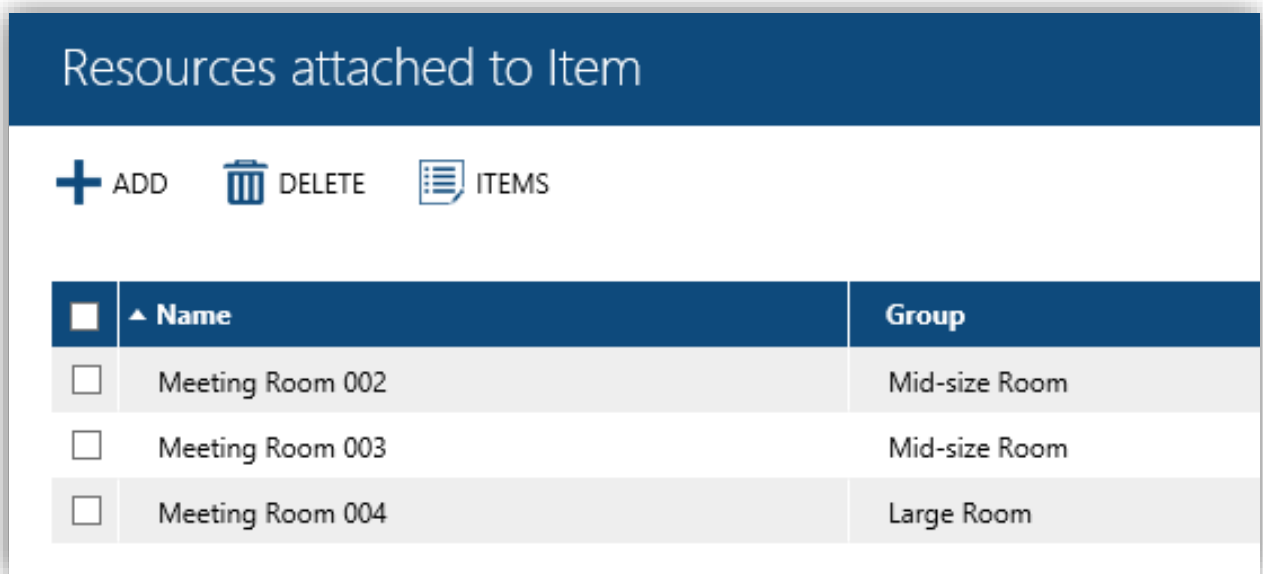

Figure 153. List of Resources for an Item

Toolbar Buttons	Description
Add	You can add resource(s) from the list of all resources
Delete	You can remove the selected resources
Items	You can go back to the Item Details window

Item: Nutrition Information

In this panel you can add nutrition information for this item.

Figure 154. Add nutrition information of an item

You can add more information for each section in 'Extra info' textbox.

If you want to configure how the data should be input, make the configuration in [Designer/Nutrition](#) section.

After the nutrition information is entered, it will be displayed when the item is selected in the order form as shown in the figure below:

Name	Price	Qty	Quota
Mineral Water	12.00		100
Coffee & Tea	12.00		100
Coffee	5.00		200

Figure 155. Nutrition information in Order Form

Item: Assignments

In this panel, you can view all Persons with Assignable roles and Informative roles given to this item.

Person	Display Name	Description	Assignable Roles	Informative Roles	Locations
AAK Cantina	AAK Cantina	pw: aak	Catering		Locations\Germany\Berlin, Locations\Ger...
admin 1	admin		admin		Locations\Germany\Hamburg\Building 8, ...
Catering	Catering 44	This is a login for the Catering peo...	Catering		Locations\Germany\Berlin, Locations\Ger...
HOST	Host (Security)	Host (Security)	Catering		Locations\Belgium\BruxellesBruxellesBruxe...
Huong 1	Huong 1	yy566		Trangtest	Locations, Locations\Belgium, Locations\Fr...
ngoc2	ngoc2		Ngoc_role		Locations, Locations\Belgium, Locations\Fr...
nguyetnhu0103	nguyet gmail		new role		Locations, Locations\Belgium, Locations\Fr...
trang	trang@aoprc.onmicr...			Trangtest	Locations, Locations\Belgium, Locations\Fr...
Trang02	Trang02	yy566		Trangtest	Locations\France\Paris, Locations\Denmar...
Trang03	Trang03	pw: aak		Trangtest	Locations\Viet Nam\Hanoi, Locations\Viet ...

Figure 156. Add nutrition information of an item

Note that here you cannot edit any information shown on this list.

In order to change the Roles for this item, refer to Roles field in [Item Details](#).

Quantity threshold

In some cases, the organizers may order certain items in large quantities which can require a longer time to prepare, have an extended deadline or could require an approval from the Service Provider before the organizer can be certain that the order can be delivered.

To configure such rules on an item, you start by setting the **Quantity threshold** which defines the threshold of the item that needs to be ordered to trigger the scenario. It is specified in under **Item details** in **RC backend**:

Item Café

LIST SAVE RESOURCE SAVE CONFIGURATION NUTRITION INFORMATION ASSIGNMENTS

Sort order

* Quota 50

Quantity threshold 10

Can be added by Organizer and Service Provider

Extra Id 1

Extra Id 2

Description

Figure 157. Quantity threshold field

The extended deadline for the item can be configured under **Item details** → **Deadlines** section:

Figure 158. Extended deadline for the item

An item's extended deadline will be applied to the item(s) that reached the quantity threshold instead of the standard deadline.

When the organizers set the item's quantity on the Order form, they can receive a message notifying that their orders would following special rules given the high quantity, e.g.:

Figure 159. Example of the message for order form

And when the organizers receive the 'New Order' or 'Changed Order' emails, they may see a message on those emails e.g.:

Figure 160. Example of the message on Changed Order email

The content of both messages mentioned above can be configured in **RC backend → Designer → Orders → [Quantity threshold messages](#)**.

Item quantity threshold calculation methods

There are 2 calculation methods to consider if an order is subjected to a quantity threshold or not: either **individual item** calculation or **item group** calculation. You can switch between these 2 methods using the parameter **OrderForm.QuantityThreshold.Group** (refer to the **Parameter Guide**). Below examples will show the difference and include the extended deadlines in the example as well.

Method 1: Individual item calculation

With this method, the order will be considered each item individually based on the configured quantity threshold. And it will use the extended deadline instead of the standard one.

For example:

- The quantity threshold of **Coffee = 30**
- The item's workdays before the **standard deadline = 1 day**.
- The item's workdays before the **extended deadline = 4 days**.
- The actual ordered quantity of **Coffee** in the order form **>= 30**

→ This order is subjected to the configured rules around The Quantity Threshold because the ordered quantity of **Coffee** reaches its specified quantity threshold above.

Also, its workdays before the deadline are 4 days due to the extended deadline

NOTE: If the ordered quantity of an item reaches its quantity threshold and the reservation date triggers its extended deadline; the item cannot be ordered, and the following message will be shown:

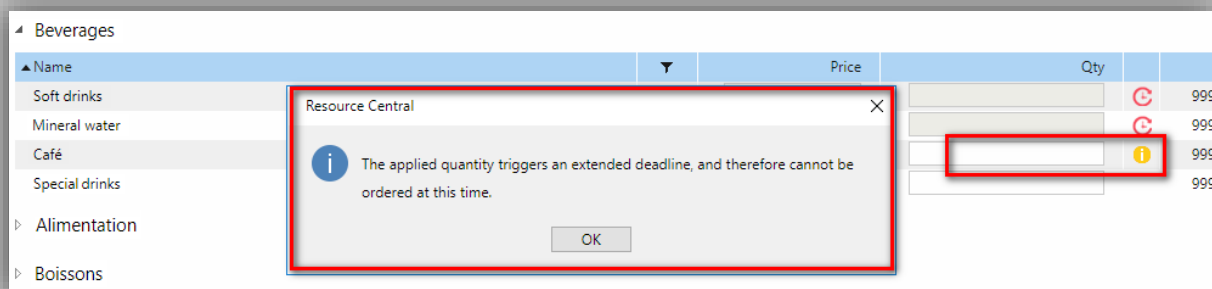

Also, that item's quantity will be reverted back to blank and it is marked with **i** icon.

If the order is re-opened and the quantity of an item is changed to the point of reaching its quantity threshold, yet the reservation date triggers its extended deadline; the message above will be shown and the item's quantity will instead be reverted back to the number saved before the change.

Method 2: Item group calculation

With this method, the order will be affected by the quantity threshold if the total ordered quantity of multiple items in the same group **reaches the minimum quantity threshold among the ordered items**. And it will use the **extended deadline of the item with highest workdays before the deadline**.

For example:

- The organizer ordered **Coffee** and **Tea**, both are in **Beverage** group.
- The quantity threshold of **Coffee = 30**
 - *Coffee's* workdays before standard deadline = 1 day.
 - *Coffee's* workdays before extended deadline = 3 days.
- The quantity threshold of **Tea = 40**
 - *Tea's* workdays before standard deadline = 2 days.
 - *Tea's* workdays before extended deadline = 4 days.

- The total ordered quantity of **Coffee** and **Tea** in the order form = **35**

→ This order is subjected to the configured rules around The Quantity Threshold because the total ordered quantity of **Coffee** and **Tea** reaches the specified quantity threshold of **Coffee**.

Also, the order's workdays before the deadline are 4 days due to the item **Tea** having the highest workdays before the extended deadline.

NOTE: If the total ordered quantity of multiple items in the same group reaches their lowest quantity threshold, yet the reservation date triggers their longest extended deadline, e.g.:

- The organizer ordered **Café** and **Soft drinks** in Beverages group.
- **Soft drinks'** quantity threshold is **50**, and extended deadline is **4 workdays** prior.
- **Café's** quantity threshold is **40**, and extended deadline is **3 workdays** prior.
- The total order quantity of **Café** and **Soft drinks** in the order form is **40**.
- The current date is **Jan 17th**, and the reservation date is **Jan 20th**.

→ This order is subjected to the configured rules around The Quantity Threshold because the total ordered quantity reaches the lowest quantity threshold among 2 items (**Café's** quantity threshold is **40**). But because the reservation date triggers the extended deadline of the **Soft drinks** (within 4 workdays), the items cannot be ordered and the following message will be shown:

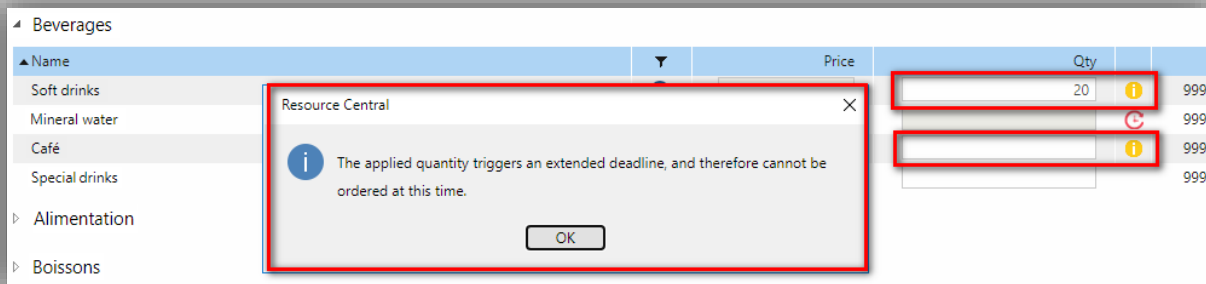

Also, the latest change of item quantity will be reverted to blank, and all those items are marked with the **i** icon.

In case the order is re-opened, and the quantity of an item is changed to the point of reaching quantity threshold, yet the reservation date triggers the extended deadline; the message above will be shown and the item's quantity will instead be reverted back to the number saved before the change.

Reminder Email

In case you want to remind the organizers of their upcoming orders that are affected by the item quantity threshold, you can enable the reminder email function using the parameter **RC.QtyThreshold.ReminderMail.Enable**.

When enabled, the reminder email is controlled by 2 additional parameters:

- **RC.QtyThreshold.ReminderEmail.Days:** determines the number of days before the extended deadline, standard deadline, or the catering deadline that the reminder emails will be sent to the organizers.
- **RC.QtyThreshold.ReminderEmail.StartTime:** determines the start time of the day that the reminder emails will be sent.

(For more details on these 3 parameters, please refer to **Resource Central Parameter Guide**)

For example:

- The current date is Feb 4th
- The meeting with order is on Feb 18th
- The extended deadline = 5 days → the actual extended deadline date is Feb 13th
- The standard deadline = 3 days → the actual standard deadline date is Feb 15th
- The catering deadline = 4 days → the actual catering deadline date is Feb 14th

- Value of the parameter **RC.QtyThreshold.ReminderEmail.Days** = 4 days
 - Value of the parameter **RC.QtyThreshold.ReminderEmail.StartTime** = 080000 (meaning 08:00 AM)
- Among the 3 deadlines, the function will prioritize the one nearest to the current date. In this example, it is the extended deadline (Feb 13th). The reminder mail will be sent 4 days before this deadline, specifically on Feb 9th.

When the reminder email is sent, the `Reservations.IsSentReminderMail` is updated to '1' and the reminder email will not be sent again for that order.

NOTE: In case a deadline date is already reached, yet the reminder mail is not sent; the reminder mail will be sent on the next day for all the deadline that have not sent the mail yet. E.g.:

In the scenario above, IF the reminder mail for extended deadline **was not sent on Feb 9th**; on **the next day Feb 10th**, **the reminder mail will be sent** for both catering deadline (on Feb 14th) AND extended deadline (on Feb 13th).

Similarly, IF the reminder mail **was still not sent on Feb 10th** for both catering deadline and extended deadline, **on Feb 11th the mail will be sent again for all 3 deadlines** including extended deadline (Feb 13th), catering deadline (Feb 14th), and standard deadline (Feb 15th).

The reminder email will contain a message notifying the deadline, e.g.:

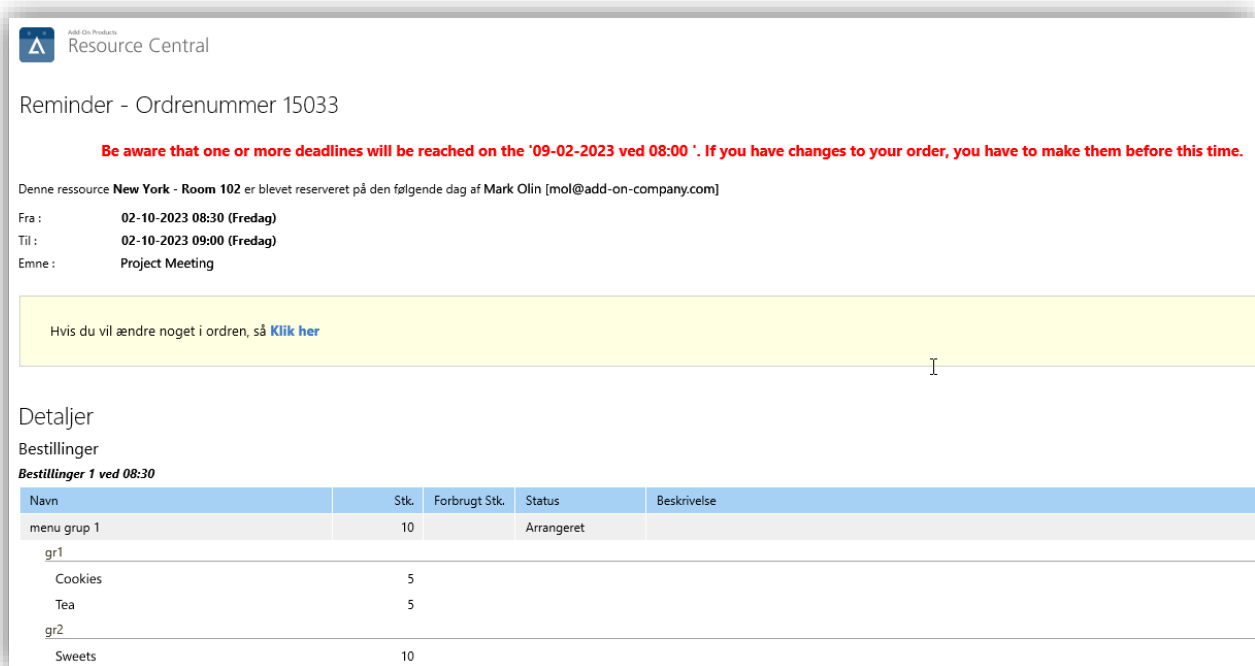

Figure 161. Reminder email

Item: Bulk update

Resource Central allows you to update multiple items at the same time by selecting items you want to update and clicking **[Bulk Update]** button on the toolbar:

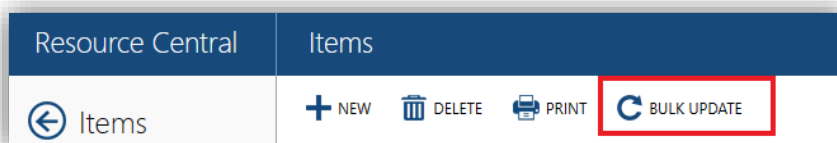

Figure 162. Items mass update button

Item bulk update panel basically consists of 2 columns: **Field** and **Value**.

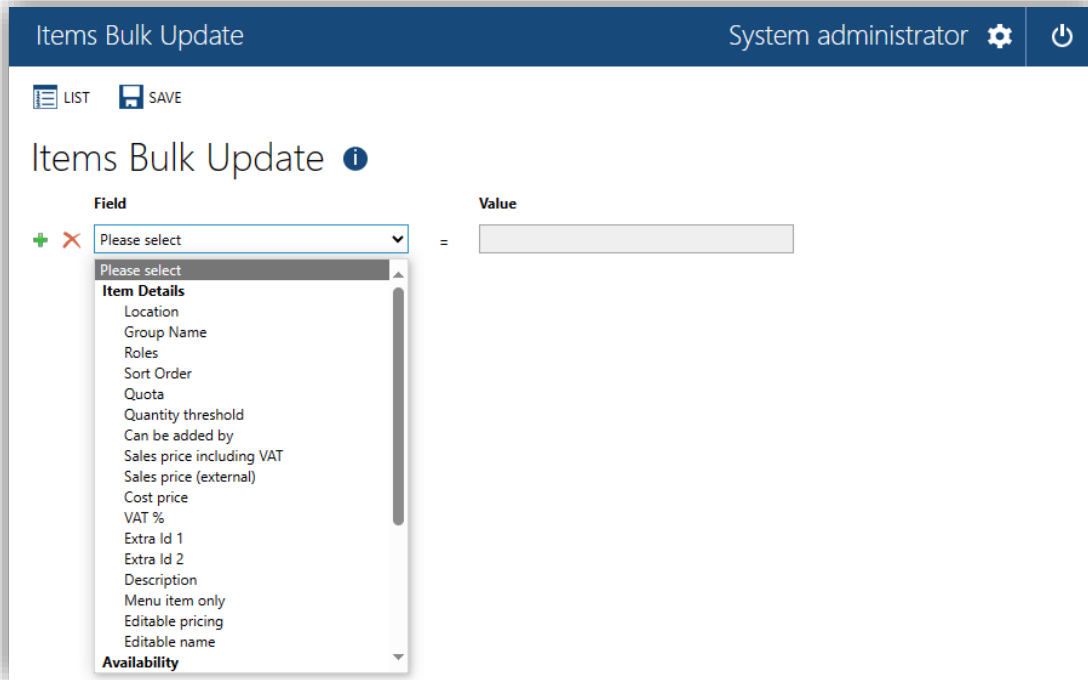

Figure 163. Items mass update panel

In the **Field** column, you can add the fields you want to update to the selected items by clicking [+] button and selecting a specific field from the drop-down list. Click on the arrow button to open the drop-down list and all item fields are displayed for you to select.

After selecting the field, you can fill in **Value** column with the relevant inputs.

NOTE:

- When the value of **Extended Item Deadline** field is 'Yes', the 'Quantity threshold' value must be greater than 0.
- If the values of **Extended Item Deadline** and **Deadline for the item** are 'Yes', the value of 'Workdays before extended deadline' must be greater than the value of 'Workdays before deadline'.

Click [**Save**] to finish.

Menus

Here you can manage menus, which must always be composed of existing items.

No.	Name	Group Name	Sort order	Status
15	Reception Menu 1	Medium	1	Active
5	Sandwich menu 1	Medium	2	Active
8	Sandwich menu 2	Medium	4	Active

Figure 164. List of menus

Toolbar Buttons	Description
New	Create a new menu
Delete	Delete selected menu(s)
Print	Print the selected menu(s)

Create or edit a menu

Click **[New]** to create a new menu, or click on an existing menu to open its details:

Item Details

* ID:

* Location:

* Group name:

* Roles:

Name:

Sales price including VAT:

Sales price (external):

Cost price:

VAT %:

Extra Id 1:

Extra Id 2:

Description:

Menu item only

Editable pricing

Editable name

Availability

Start time:

End time:

Active weekdays: Mon Tue Wed Thu Fri Sat Sun

Start date:

End date: No end date

Available for: Internal External

Deadlines

Deadline for the item

Workdays before deadline: Time:

Extended Item Deadline

Workdays before extended deadline: Time:

Figure 165. Details of a menu



Field	Description
MENU DETAILS	
ID	A code for identifying the record.
Name	The text presented to the meeting organizer when being asked for this item.
Location	Select the locations of the menu (mandatory) The locations must be defined in ' Locations ' tree under Location node.
Group Name	Group Name can be used for categorizing the items.
Roles	Role link to this menu
Sort Order	Sort order can hold any alphanumeric values and are used for sorting items.
Quantity threshold	A threshold when ordering items above a certain quantity. If the item's ordered quantity reaches the specified threshold, the order can trigger e.g., a customizable warning to the organizer, have an extended deadline and be marked in The Order Overview. For more details refer to Quantity threshold .
Image for Service Provider	Select image to be used in customized reports for Service Provider
Sort Order	Sort order can hold any alphanumeric values and are used for sorting items.
Cost Price	Sales price is the price of the item. A value 0 indicates that no calculation should be made.
VAT %	Percentage of VAT.
Minimum quantity	Minimum quantity of this menu that must be ordered
Extra ID 1 and 2	Fill in alphanumeric data. These 2 fields serve retrieving results for a custom report
Description	Description about the menu
Editable pricing	It allows that the menu can be configured to have an editable Sales price. When configured the service provider can manually change the menu price via RC backend → Orders or Service Provider's email . NOTE: This option is only available if the value of parameter Enable.EditableItem is '1'. Refer to Parameter Guide for more details.
Editable name	It allows that menu can be configured to have an editable name. When configured the service provider can manually change the menu name via RC backend → Orders or Service Provider's email . The edited name will only be applied in that order only. NOTE: This option is only available if the value of parameter Enable.EditableItem is '1'. Refer to Parameter Guide for more details.
Can be added by	Select the person(s) who can add this menu
Image for Order Form	Select image to be used in the order form
AVAILABILITY	
Start date & End date	Time range established to define availability period of the menu
Start time & End time	
Active weekdays	
No end date	Check this option to NOT have the end date, meaning the menu is always available starting from the start date.

DEADLINES	
Deadline for the menu	Enable deadline for booking the current menu.
Workdays before deadline & Time	Time range established to define deadline to book the menu.
Extended Menu Deadline	Enable extended deadline for booking the current menu. It is applied when the menu's ordered quantity is reaches The Quantity Threshold.
Workdays before extended deadline & Time	Time range established to define extended deadline to book the menu.

Toolbar buttons	Description
Save	Saves the information edited in the Input fields
List	Displays the list of menus
Resource	Displays the list of resources with which the menu is associated (see details below)
Save Configuration	The values in all the fields will be saved so that the next time when the user clicks NEW to create a new menu, all of the fields will be pre-populated with those saved values. (Value in the 'Name' field will not be saved).
Menu Content	Add items to the menu
Assignments	View the list of all Persons with Assignable roles or Informative roles given to this menu.

Add items to the menu

Click on [**Menu Content**] to configure the menu. An item can be applied to more than one menu.

Menu items are put into groups. A new group is created with the [**Add**] button and is deleted with the bin.

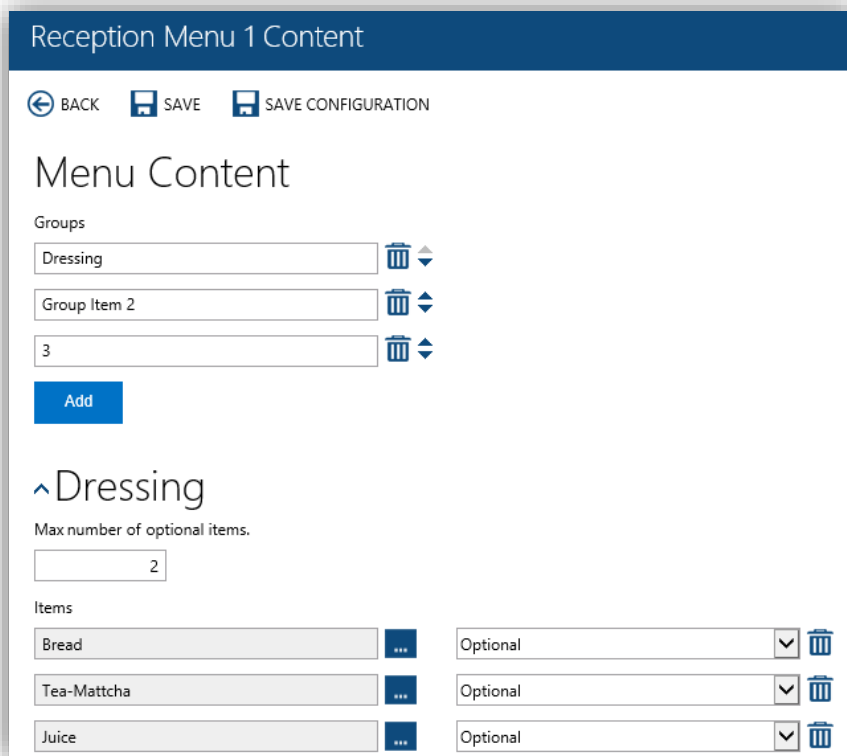

Figure 166. Add items to a menu

When you type the name of item group into the text field under **[Groups]** heading, it will be instantly applied. Add or remove as many items as you wish to the menu. Then click **[Save]** to finish.

Visitors

The visitor section is used for managing visitors on a daily basis and for future arrivals.

It is based on a Dashboard view, which supports creating, changing, and deleting visitor entries.

For optimal visitor management the visitor dashboard has different views that supports listing of meetings for the day or listing by arrival time. Multiple changes can be made based on filtering of visitors.

For immediate visitor status information, features as current arrivals and departures are also available.

All the visitors who have been registered will be listed here. The list of visitors is displayed specific to the logged in user's location. If the logged in person has the same location as that of the Visitor, then only he/she will be able to view the Visitors. Moreover, if the visitor is registered at the child location(s) of the logged in person, they will also be displayed to the user.

You can also create new visitors by clicking **"New"** apart from the visitors registered through Order Form. These newly created visitors can be associated with a reservation, department, or person.

When a visitor is registered, he/she will need authorization before his/her Arrival status can be changed. This can also be done on this Visitors list (aside from the authorization email sent to authorizers).

In addition, the system can send a **Visitor Arrival Notification** to the organizer or the Host upon the arrival of the visitor in the form of an email when the bar code of that visitor is entered in the bar code control.

Email	Arrival Status	Auth. Status	Location	Name	Meeting Subject	Badge type	Visitor T
Meeting at: 04:00 Subject: Internal Meeting Organizer: Sam Smith[dmn@rc							
h1@ps.com	👤	Awaiting	Locations\France	H1	hu2	Badge1	
h2@ps.com	👤	Awaiting	Locations\France	H2	hu2		
Meeting at: 04:15 Subject: Internal Meeting Organizer: Sam Smith[dmn@rc							
h3@ps.com	👤	Awaiting	Locations\France	H3	hu3		
h4@ps.com	👤	Awaiting	Locations\France	H4	hu3	test aop de...	
Visit at: 04:28 Person: Internal Meeting							
t1@ps.com	👤	Awaiting	Locations\France\...	H5		Use QR Code	Family
t2@ps.com	👤	Awaiting	Locations\France\...	H6		test aop de...	Family
Meeting at: 08:00 Subject: Or1 Organizer: Nguyen Luong [ngu							
a1@aod.vn	👤	Awaiting	Locations\USA	a1	Or1		Visitor
a2@aod.vn	👤	Awaiting	Locations\USA	a2	Or1		Visitor

Figure 167. List of Visitors

Toolbar Buttons	Description
New	You can create a new visitor
Import Visitors	Import visitors from an Excel file.

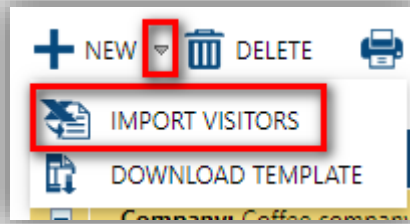

Clicking the button will opens a new window for you to select Excel file to import:

On this window, you can select an Associate Type among 3 options: **Reservation**, **Person**, and **Department**. Select/import the filters, then upload an Excel file from your machine to import visitor details via 'File name' field.

The figure above demonstrates the case you select **Reservation** as Associate Type. After selecting a Reservation Name, its ID will be automatically filled in the 'Reservation Number' field. Once you are done, click [**Import**] to import visitors from the Excel file for the selected reservation.

NOTE:

- The Arrival / Departure field cannot be edited as it depends on the chosen reservation.
- All dropdown lists mentioned above only include standard resources, specifically: Resources that are standard type, Organizers who booked standard resource, and Reservations in standard resource.
- The Light resource and Pooled resources (which are not available for Ordering) will NOT be included.

If you select **Person** as Associate Type, it should assemble the following figure:



The screenshot shows a dialog box titled "Resource Central" with a close button in the top right. The main heading is "Import visitors from Excel spreadsheet". Below this, there are several input fields: "Selected date" with a text box containing "Friday, 2024/05/24"; "Arrival / Departure" with two dropdown menus, both showing "06:26"; "Associate Type" with a dropdown menu showing "Person"; and four empty text boxes labeled "Person:", "Location:", "Host:", and "File name:", each with a blue button containing three dots to its right. At the bottom of the dialog are three buttons: "Download Template", "Import", and "Close".

Once you are done, click [**Import**] to import visitors from the Excel file.

If you select **Department** as Associate Type, it should assemble the following figure:

The screenshot shows the same dialog box as above, but with the "Associate Type" dropdown menu set to "Department". Consequently, the text box below it is labeled "Department:" instead of "Person:". The other fields and buttons remain the same.

Once you are done, click [**Import**].

NOTE: The field of Arrival / Departure is editable for **Person** and **Department** associate types only.

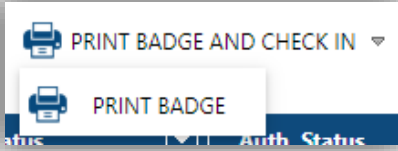
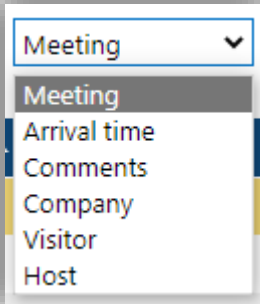
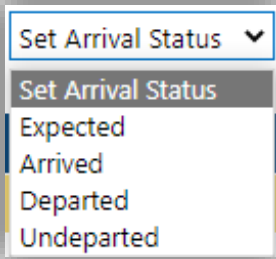
Download Template	Download an Excel template file in which visitor details can be filled in and after that, you can upload it if you wish.
Delete	Delete the selected visitors
Print Badge	 <p>Clicking the button will open the printer interface window.</p> <p>If you click [Print] on the Printer Interface window, all the badges for all those visitors who have Arrival status as 'Expected' would be printed, one badge per page.</p>
Print Badge and Check In	Print badges of visitors with Arrival status 'Expected' and check them in.
Meeting filter	<p>Change the view of Visitors based on either: Meeting, Arrival time, Comments, Company, Visitor, or Host.</p> 
Set Visitor Status	<p>Select visitor(s) on the list, then choose a status on 'Set Visitor Status' drop-down list to apply that Arrival status to all selected visitors.</p>  <p>NOTE: You cannot change Arrival status of a visitor whose 'Authorization status' is not set yet. For more details, refer to Visitor Authorization section.</p>

Enter the ID of a visitor in the field and click the button. It will help change Arrival status of that visitor.

The changing rule is as follows:

- **Expected to Arrived**
- **Arrived to Departed**
- **Undeparted to Departed**
- **Departed to Expected**

Press **[Enter]** or  icon:

- If **RC.Visitors.CheckinByCode.ShowDetail.Enable** parameter is disabled, the Arrival status of that visitor will immediately change according the above rule.
- If **RC.Visitors.CheckinByCode.ShowDetail.Enable** parameter is enabled, a screen of Visitor Details and Visit Information will appear to show who is about to check in/out, e.g.:

**Enter
Visitor ID**

Then, click **[Check in/out]** and the Arrival status of that visitor will change according the above rule.

For more details of **RC.Visitors.CheckinByCode.ShowDetail.Enable** parameter, please refer to **RC Parameter Guide**.

**Resend
Code**

Resend email with registration code to selected visitors.

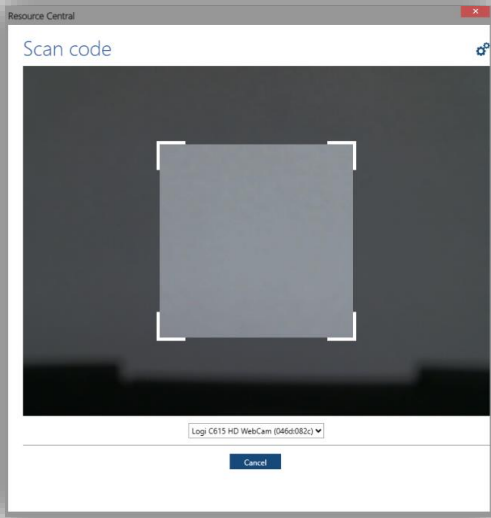

Hide Previous	<p>This checkbox works in conjunction with the parameter Visitors.HidePrevious.Minutes.</p> <ul style="list-style-type: none">• If parameter Visitors.HidePrevious.Minutes is created with positive integer value in the range of (0, 180] minutes (i.e., less than or equal to 180 minutes) → all visitors with arrival time < (current time – value of the parameter) will be hidden when you check on [Hide Previous].• If parameter Visitors.HidePrevious.Minutes is NOT created or created with invalid value or with value larger than 180 (minutes) → all visitors with arrival time < current time will be hidden when you check on [Hide Previous].
Set Authorization Status	<p>Change authorization status of the selected visitors who have visit in your assigned locations, either Awaiting, Authorize, or Declined.</p> <ul style="list-style-type: none">• Awaiting: means the visitors require authorization before their Arrival status can be changed.• Authorize: means the visitors are authorized to visit, their Arrival status can now be changed.• Decline: means the visitors are refused to visit, their Arrival status cannot be changed. <p>To be able to change a visitor's Authorization status, the persons in respective location must be assigned with the Role that can change authorization status.</p> <p>Please refer to Person: Roles on how to assign Role to a person, and Role Details to know how to allow a Role to change authorization status.</p>
Scan Code	<p>Opens a dialogue to scan the code of a visitor e.g. the QR code. When scanned a visitor/visit information dialogue can (configurable see below) be present to show the details of the visitor that you are about to check in or out.</p> <p>Click on the Scan Code button and the camera screen appears to scan the visitor's QR code:</p>  <ul style="list-style-type: none">• If RC.Visitors.CheckinByCode.ShowDetail.Enable parameter is disabled, the Arrival status of that visitor will immediately change according to the above rule.



- If **RC.Visitors.CheckinByCode.ShowDetail.Enable** parameter is enabled, a screen of Visitor Details and Visit Information will appear to show who is about to check in/out, e.g.:

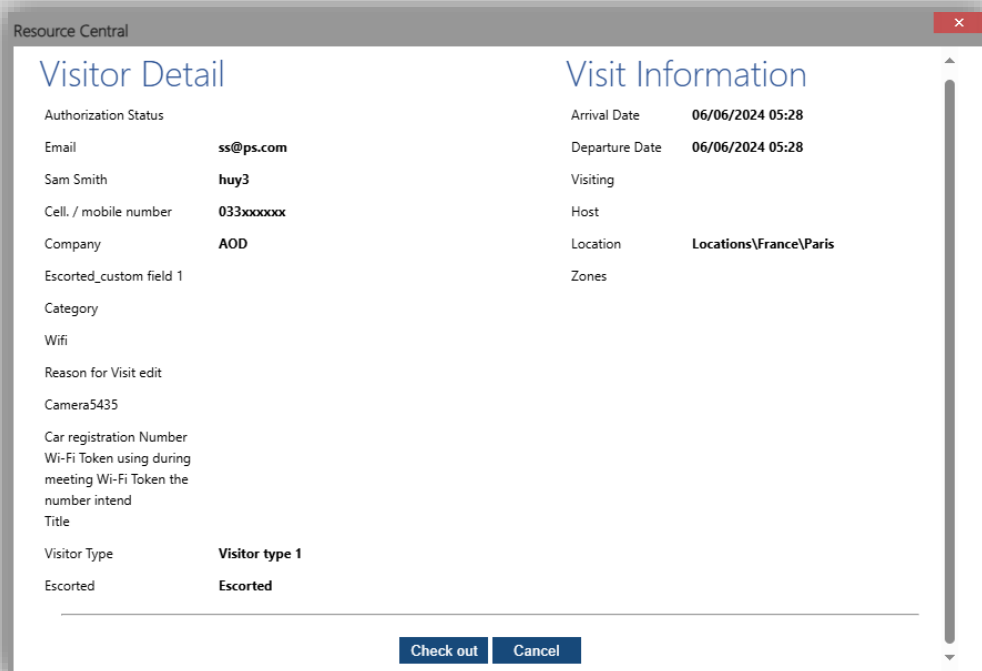

Then, click **[Check in/out]** and the Arrival status of that visitor will change either arrived or departed.

For more details of **RC.Visitors.CheckinByCode.ShowDetail.Enable** parameter, please refer to **RC Parameter Guide**.

This function is designed to export a list of visitors who have currently checked in.

Click on  icon on the toolbar to select an available template for the visitor emergency report. Select a template and click **[Run report]**.

Emergency

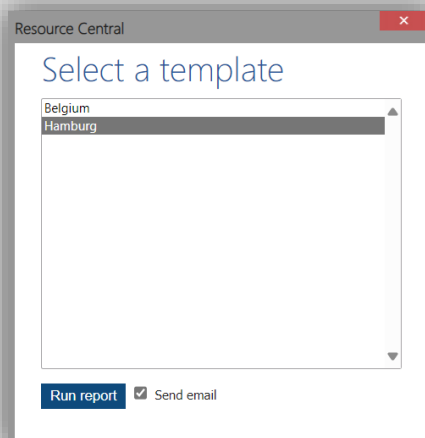

If the report is configured with an email the check box **[Send email]** will be checked and the report result will go to the preset emails.

Report conditions

Date: Wednesday, May 8, 2024

Report Template: Australia

Locations: Perth, Sydney, Resource Delegate, Australia

Expected Arrived Undeparted Departed

Report result

Visitor Emergency Report

Date: 2024/05/08
Locations: Perth, Sydney, Resource Delegate, Australia

Locations: Australia

Visitor ID	Resource name	Is Recurring	Comments	Auth. Status	Authorizer comment	Host	Location
00000004922		No					Locations\Australia

The result on the current date will be automatically exported. You must notice that the default Arrival Statuses for the report are "Arrived" and "Undeparted". You can reselect the conditions on this screen and click **[Run Report]** or **[Run and Send Emails]** for a new result.

To create report templates, refer to [this section](#) for configurations.

You can configure your own personal view in the Visitor overview. You can add, delete, and change position of the columns shown on the Visitors list. The available columns depend on the Visitors fields configured in **Designer → Visitors**. Once you finished your changes, click **[Save]**.

Column Options

Column options

- Arrival Status
- Auth. Status
- Meeting Subject
- Location
- Arrival Time
- Departure Time
- Email
- Company
- Visitor ID
- Resource name
- Organizer

+ Add a column

Save Cancel Reset

	<p>NOTE: These changes only apply per person, meaning it does not affect other RC System Admin users.</p>
<p>Status Filter</p>	<p>You can filter the listed records through the Status Filter located at the upper-right corner of the toolbar (just under [Logout] Button).</p>  <p>By selecting either of the 4 status filters, the corresponding visitors would be filtered accordingly as shown below.</p>

Visitor Arrival Notification

When a visitor checks in, Resource Central can send a **Visitor Arrival Notification** to the organizer upon the arrival / registration of this visitor. The “notification” will be in the form of an email or text message sent to organizer. This all depends on the availability of the feature SMS notification which can be configured in **RC backend → System → SMS Configuration**.

Option 1: SMS notification disabled

When you put in a valid barcode in the bar code control and click the button, you will be presented with a message that if you want to inform the organizer about the arrival of this visitor or not, as shown below:

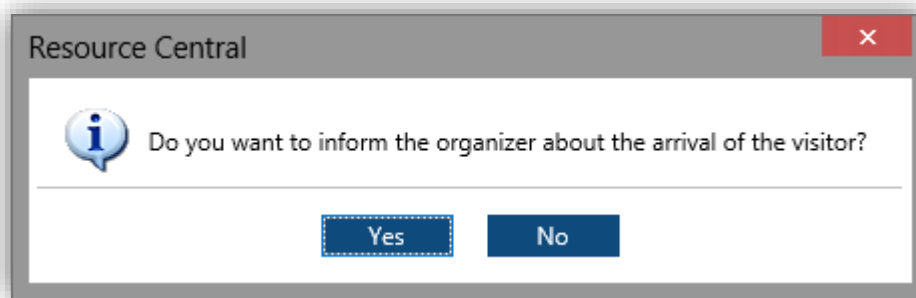

Figure 168. Visitor Arrival Notification Message

This message will only appear if value of **Visitor.Arrivalalert** Parameter is '1'. If this parameter is not created or it has '0' value, this alert message will not show up.

For more details about creation of this parameter, please refer to **Resource Central Manager → General → Parameters**.

If you select '**NO**', the organizer will not be informed, and no email will be sent.

Selecting '**YES**' will send an email to the organizer, notifying the arrival of that particular visitor as below:

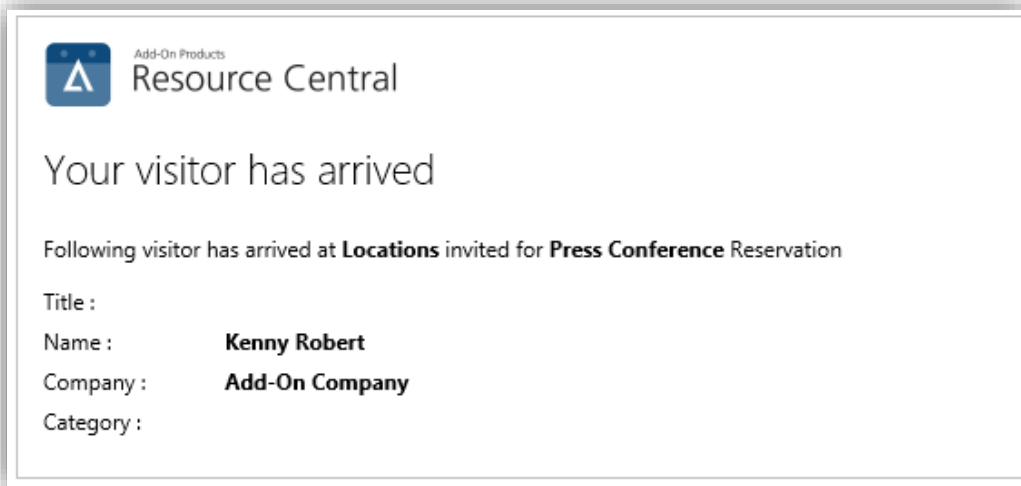

Figure 169. Visitor Arrival Email sent to the Organizer

Option 2: SMS notification enabled

RC supports sending text messages or emails to meeting organizers to notify them of visitors' arrival. You can select visitor in the list, click **[Notification]** button on the toolbar, and the following window shows up:

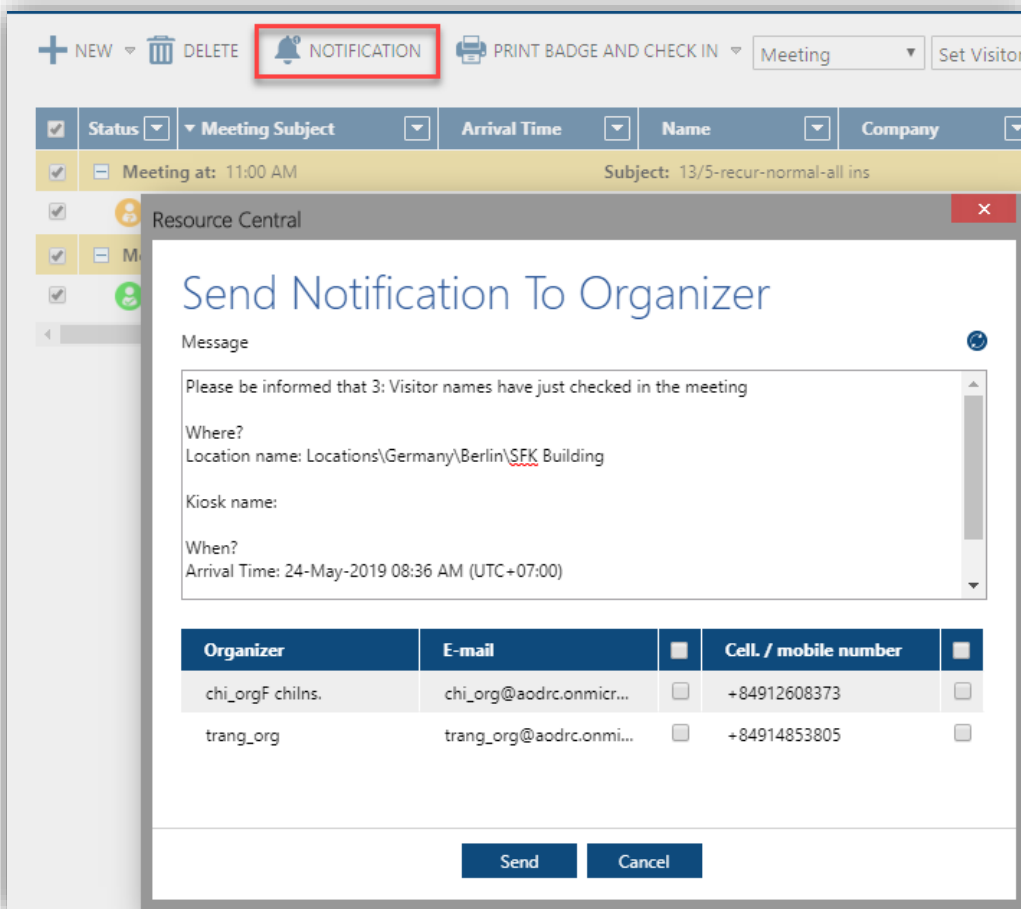

Figure 170. Configure Notification to meeting Organizer

In this panel, you can select notification options (by email or text message to organizer's cell phone). After making your selection or changing the message content as you wish, click **[Send]** to finish.

Visitor Details

Click on any of the listed visitors will show the details of that visitor. It includes:

Visit Information

This section shows the visit details.

^ Visit Information

Arrival Date	Departure Date
September/21/2022 18:00	September/21/2022 18:10
Associate Type	Reservation Name
Reservation	Project Meeting
Host	Zones
tmc@add-on-company.com	Conference Zone, Canteen

Field	Description
Arrival Date	Expected date of the visitor's arrival.
Departure Date	Expected date of the visitor's departure.
Associate Type	The associate type of the visitor.
Reservation Name	The name of the reservation that this visitor is invited to.
Host	The email address of the host who will take care of this visitor.
Zones	The zone(s) that this visitor is invited to.

If you are viewing the details of an existing visitor, the fields above cannot be edited.

If you add a new visitor via Visitors list, the fields above can be edited.

Approving Status

This section shows the Authorization status of a visitor based on location/zones that he/she is invited to.

^ Authorization Status Set Authorization status ▼

Location & Zones	Auth. Status	Authorized by	Authorizer comment
Nguy Internal1	Awaiting ▼		
NguyetInternal2	Awaiting ▼		

Field	Description
Location & Zones	The name of location/zone.
Auth. Status	The current Authorization status. If you have are the authorizer, you can change the status.
Authorized by	The email address of the authorizer.
Authorizer comment	The comment of the authorizer.

These fields only display the current results; thus, they cannot be edited.

Visitor Details

This section shows and allows you to edit the details of the selected visitor.

The fields displayed here depend on the ones in **RC backend** → **Designer** → **Visitors**, including custom visitor fields that you can create (e.g., the custom fields in the example below are 'Reason for visit', 'Address', 'Wifi access',...). For more details on these custom fields, please refer to this [section](#).

Figure 171. Details of a Visitor

Field	Description
Visitor Id	Unique, auto-generated, non-editable barcode id for the visitor.
Status	Arrival status of the visitor. If you are authorized, you can select change this visitor's arrival status here.
Generate Registration code	Select Yes to send a code to the visitor. The visitor can receive a reminder email of the registration code which is controlled by parameter RC.Visitor.email.workdaysbefore . Refer to RC Parameter Guide for more details. When the visitor attends the meeting, he will have to enter this code to register.



Name	Name of the visitor.
Email	Email of the visitor.
Cell. / mobile number	Mobile number of the visitor.
Visitor Type	The type of visitor. This field can only be edited by authorized persons.
Company	Company of the visitor
Title	Title of the visitor.
Category	Category of the visitor.
Badge Type	Select one among the badge designs that match with the location where the visitor will arrive. For more details on badge designs, refer to this section .
Comment	Comments about the visitor.

Toolbar Buttons	Description
LIST	Go back to the list of visitors
SAVE	You can save all your changes to the visitor's data
PRINT BADGE AND CHECK IN	Print badges of visitors with status "Expected" and check them in
PRINT BADGE	Clicking this button, the printer interface would open which will directly print the badge
PREVIEW	The badge would be shown for preview purpose in a separate window, according to the badge type selected, with a Print button
SAVE CONFIGURATION	<p>The values in all of the fields will be saved so that the next time when the user clicks NEW to create a new visitor, all of the fields will be pre-populated with those saved values.</p> <p>NOTE: This will only be applicable over the current screen. The impact of this functionality will not be displayed over the Attendees section at the Order Form.</p> <p>By default, the button is enabled, but it can be disabled using the parameter Visitor.DisableSaveConfiguration. Refer to RC Parameter Guide for more details.</p>
VISIT DETAIL	<p>Open the 'Visit Detail' page which shows the information of the visit that the visitor attends to, and the details of all visitors in that visit.</p> <p>If you are the organizer, you can also edit the visitor's details.</p> <p>NOTE: Certain information changes will reset the visitor's Authorization status to 'Awaiting'. Refer to this section for more details.</p>
RESEND CODE	Resend email with registration code to selected visitors.

Identification

This section shows the identification of the visitor.

Field	Description
Id Type	Type of Identification document.
Id Number	Number of the Identification document.
Scan	Scan and preview the document.
Photo	Scan and preview the photo.

NOTE: It is recommended that you utilize the Photo option to capture portrait photos and the Scan option to capture documents.

When you click [**Photo**] button, the following pop-up page will appear, and you can select the source if you have more than 1 webcam connected. The interface will assemble the following figure:

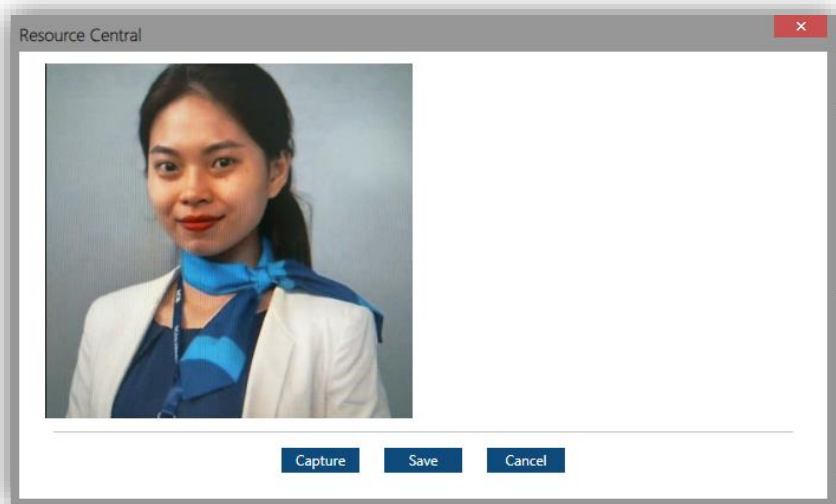

Figure 172. Twain Interface for the application

You may use this function to photograph a person. When you stand in front of the camera, you will see that the left panel displays the camera's perspective. When you press the "**Capture**" button, the portrait picture is transmitted and presented in the right panel:

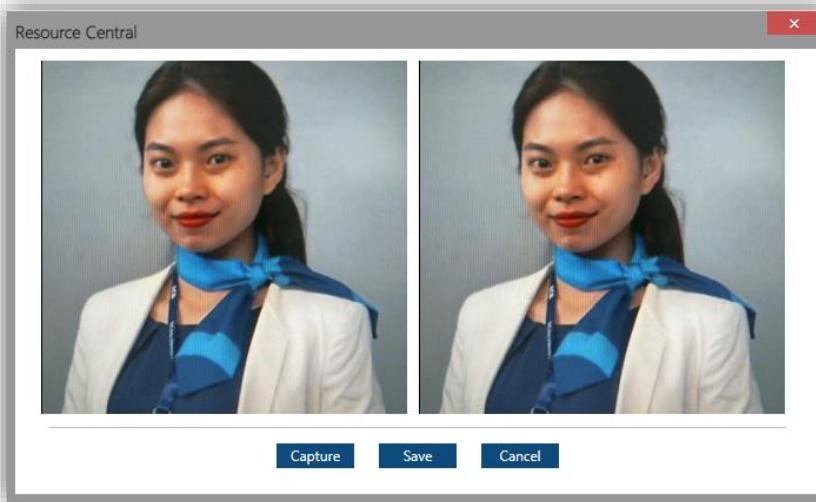

Figure 173. Preview of the picture in a new window

If you click [**Save**], the image is transferred to the corresponding frame in Visitor's details page:

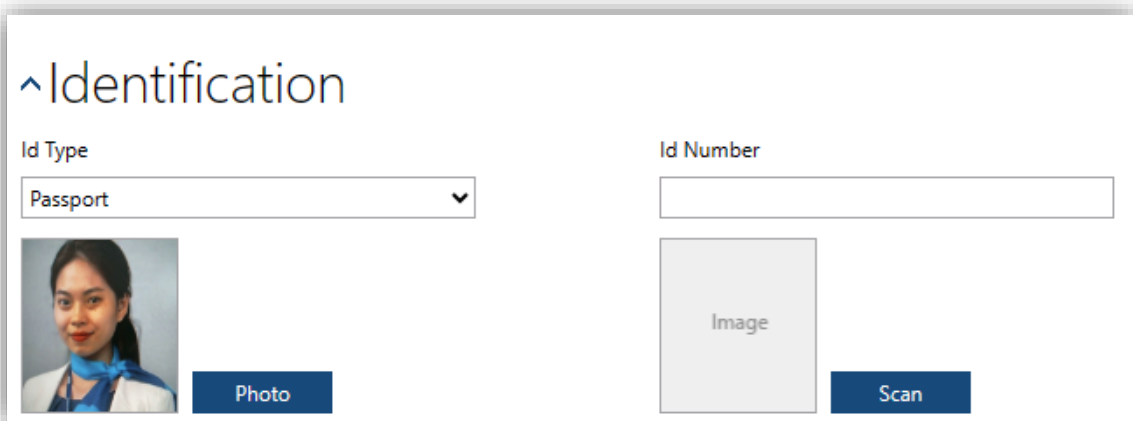

Figure 174. Picture in Visitor details

When you click “**Preview**” at the toolbar, the badge for this visitor would be printed according to the badge format specified in the Badge Type control, as shown below:

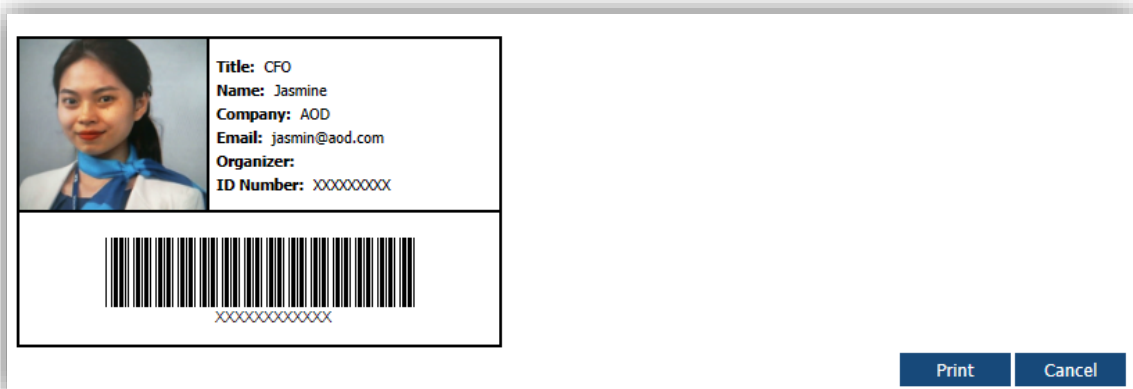

Figure 175. Badge for the Visitor

If you select **[Scan]**, a pop-up page will appear that consists of 2 windows. Select the supported webcam and bring the document near to it. The image of the document is displayed in the left window. Hold the document still and wait for the webcam to identify the content part of it. Press **“Scan”** and only text area of the document will be captured and presented in the right pane.

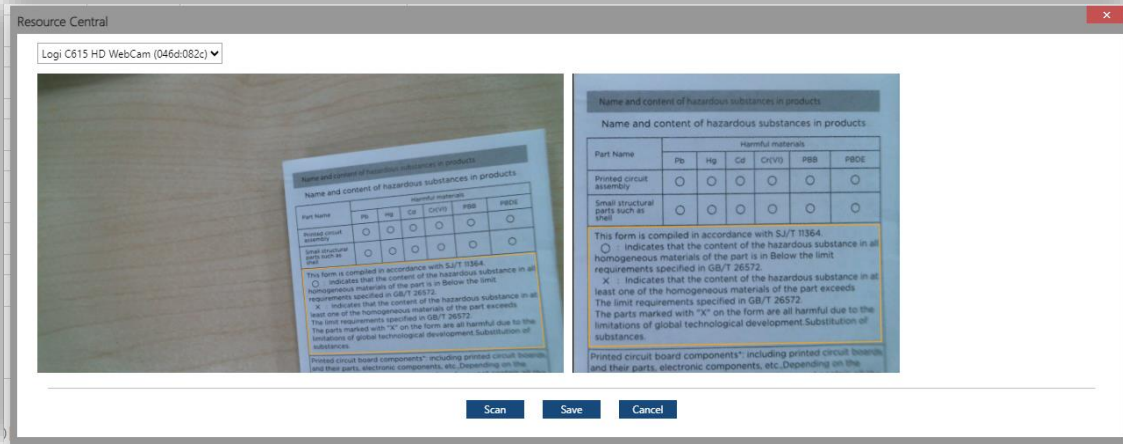

Figure 176. Scan feature

Select **[Save]** to return to New Visitor screen and you now see the capture of the document thumbnail:

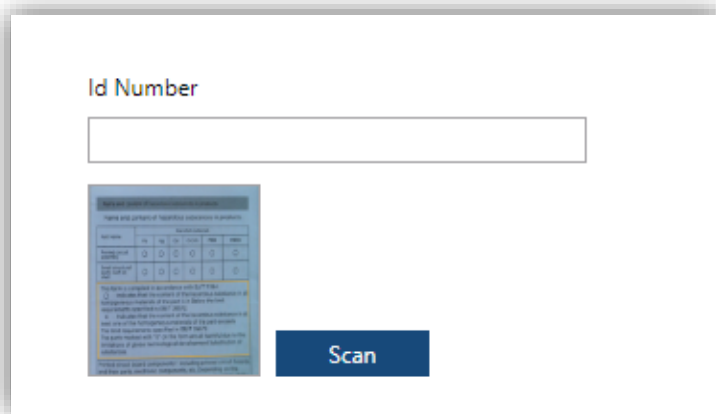

Figure 177. Scan document in Visitor details

Visitor Authorization

If the locations require visitor authorization (set in **RC backend** → **Location** → a location’s **Properties**), visitors who are registered for those locations will have their ‘Authorization status’ set as **Awaiting** to wait for the authorization by the Persons in the respective locations who have visitor authorization role.

The visitor authorization right can be given to a role in **RC backend** → **Security** → **Role**. Then that role can be assigned to a person so that he/she can authorize visitors registered for his/her locations/zones.

Their Arrival status is still set as ‘Expected’ and it cannot be changed until they get authorized (in other words, they need to get approval first before they can actually visit the premises).

Notification email to visitor authorizer

When the visitors are registered by organizers, a notification email will be sent to persons with Location or Zone Authorizer role (they must be designated to the same locations where the visit takes place).

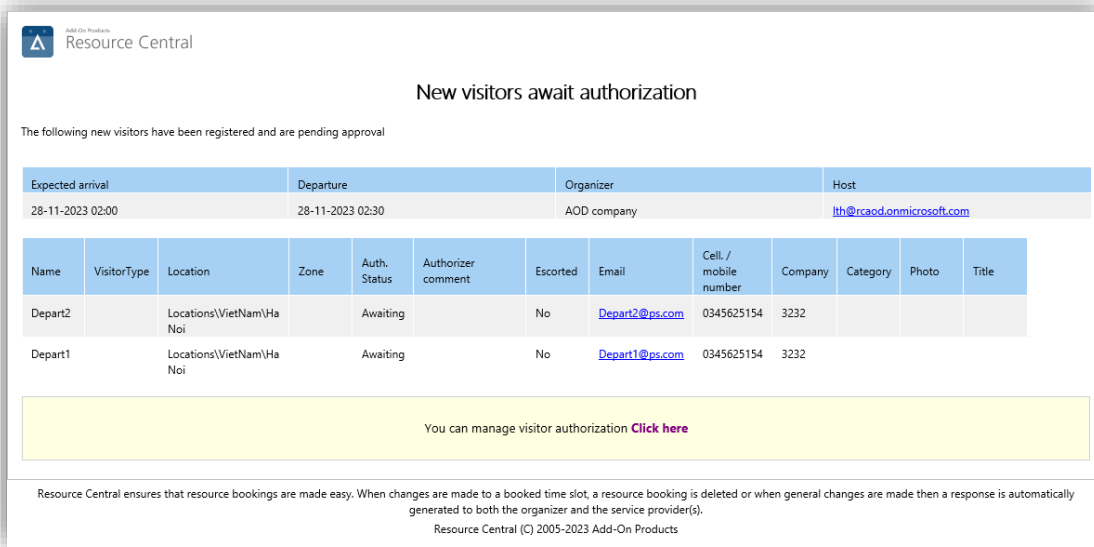
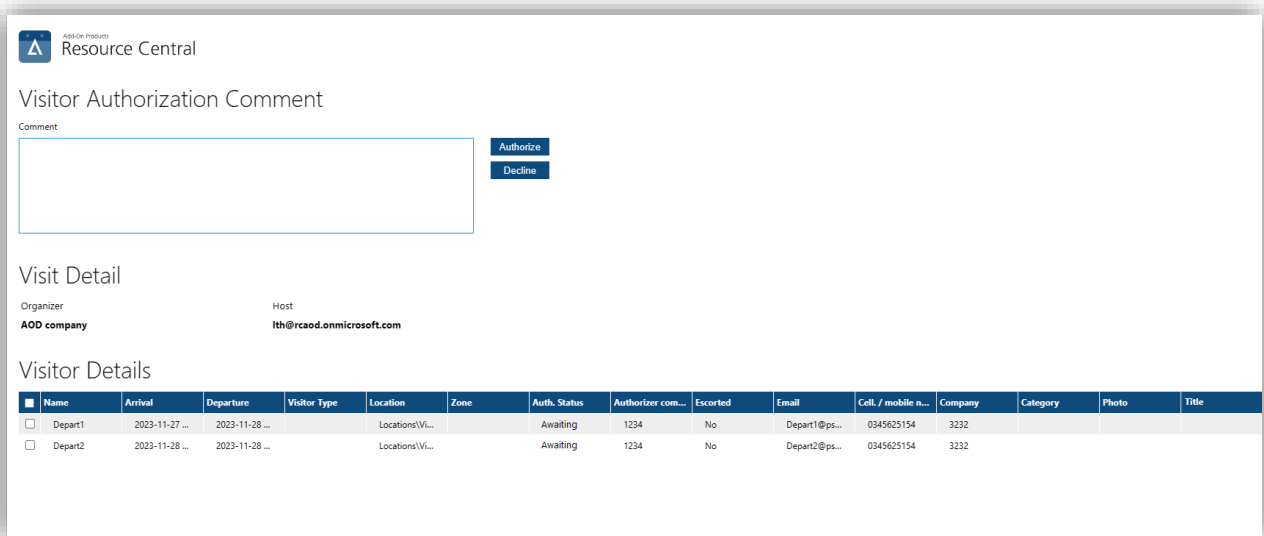

Figure 178. Notification email to visitor authorizer

Click on **[Click here]** will open the authorization screen as follows:



The 'Visitor Details' shows the zones & locations that require authorization. Here, the authorizer can only check the zones & locations that he/she is designated. After checking the location zones, the authorizer can give comment on 'Visitor feedback' and either click **[Authorize]** or **[Decline]**.

- If **authorized**, the visitor's status on **Daily Tasks → Visitors** will be changed to 'Authorized'. Then their 'Arrival status' can be changed as described in [Visitors](#) section above.
- If **declined**, the visitor's status on **Daily Tasks → Visitors** will be changed to 'Declined', and their 'Arrival status' cannot be changed.

The column content of Visitor Details in the authorization screen can be controlled by making the fields visible or invisible before the notification email is sent. This can be done in "Visitors" category under **Designer** section.

Visitor Details

Name	Arrival	Departure	Visitor Type	Location	Zone	Auth. Status	Authorizer com...	Escorted	Email	Cell. / mobile n...	Company	Category	Photo
<input type="checkbox"/> Depart1 Huo...	2023-11-27 ...	2023-11-28 ...		Locations/VL...		Authorized	1234	No	Depart1@ps...	0345625154	3232		
<input type="checkbox"/> Depart2 Huo...	2023-11-28 ...	2023-11-28 ...		Locations/VL...		Authorized	1234	No	Depart2@ps...	0345625154	3232		

Refer to [Caption and Customizable fields](#) for overview about field configuration.

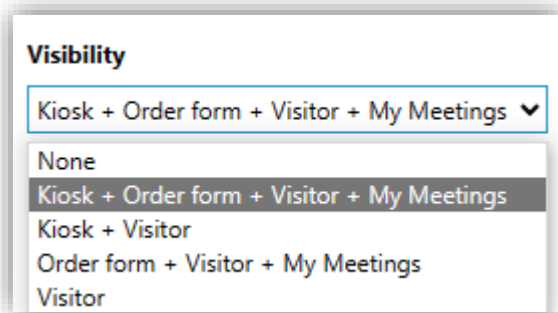

In the **Visibility** box, select the option that contains “Visitor” element to make it visible on the Visitor Details table. To make it invisible, select “None”.

Follow the same procedure for the remaining fields.

Note that this will also apply in the Visitor Module.

NOTE: This email will be sent to authorizer again if either of the following information changes:

- The visit date is moved to another day. This will reset visitors’ authorization status to ‘Awaiting’, thus they need authorization again.
- Certain information changes made to the visit, including change to new zones or locations, change of the Host, change of department name.
- Certain information changes made to the visitor, including visitor type, visitor name, escorted status.

You can set the Authorization status by directing to “Visitors” category under **Daily Task** section. Here, the authorizer can only check the zones that he/she is designated. After checking his/her responsible locations or zones, the authorizer can set Authorization status.

Visitors - Tuesday, 28-11-2023

Meeting Set Authorization status HIDE PREVIOUS COLUMN OPTIONS

Set Authorization status

Meeting Subject	Auth. Status	Arrival Time	
Person: [ntt@rcaod.onmicrosoft.com]	Authorized *	03:48	
Zones	Auth. Status	Changed by	Authorizer com
Zone 2	Declined	thanh_zone2	

- If set **Authorize**, the location status will be automatically authorized:

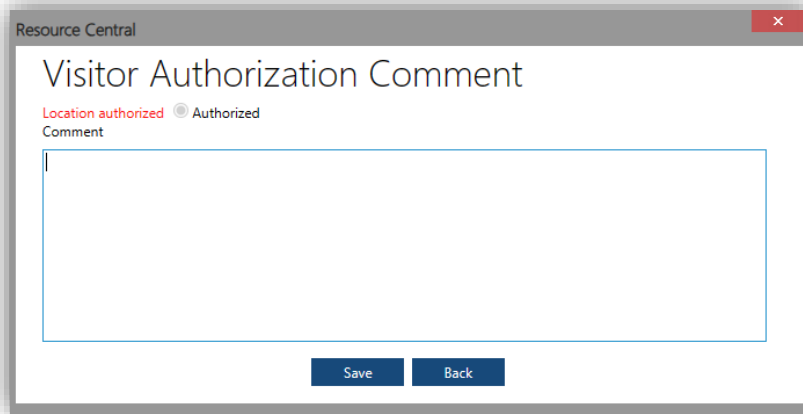

- If set **Decline/Awaiting**, the location status can be adjustable by selecting 'Authorized' or 'Decline'.

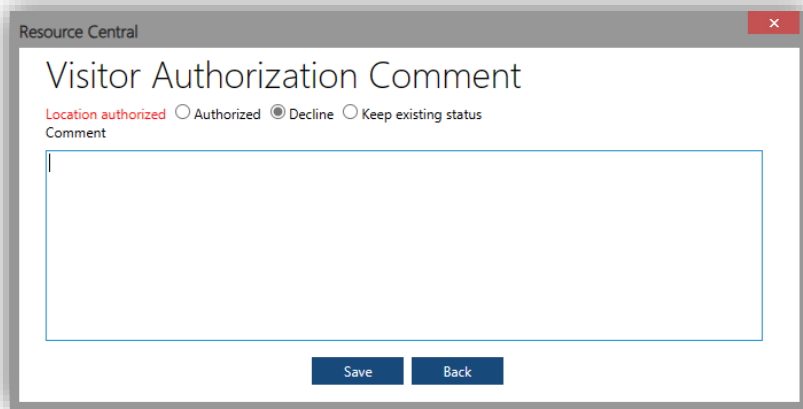

You can add Comment as desired and click [**Save**].

NOTE: If all zones are set 'Decline' a notification email will be sent to the Location Authorizer.

Reminder email to visitor authorizer

You can also set reminder email sent to authorizers several day(s) before visitors' arrival date in case the visitors' authorization status is still 'Awaiting'. E.g.:

Resource Central

Visitors that are pending approval

Overview

The following visitors are pending approval

Expected arrival	Departure	Organizer	Host
September/16/2022 09:30	September/16/2022 10:00	Thomas Conrad	tmc@add-on-company.com

Name	Visitor Type	Location	Zone	Approval	Message
Kimberly Jackson	Consultant	Locations\US\New York		Pending	
			Conference Zone	Pending	
			Showroom Zone	Pending	
			Developers Block	Pending	

You can manage the approvals [Click here](#)

Figure 179. Reminder email to visitor authorizer

This feature is controlled by 3 following parameters:

- **Visitor.Approval.ReminderEmail.Enable**
- **Visitor.Approval.ReminderEmail.Starttime**
- **Visitor.Approval.ReminderEmail.Days**

For more details on these 3 parameters, please refer to **Parameter Guide**.

Notification email to organizer

When the visitor is authorized/declined, the organizer will receive a notification email about his/her visitor authorization status. E.g.:

Resource Central

Visitors

The following visitors are expected:

Expected arrival	Departure	Organizer	Host
September/16/2022 09:30	September/16/2022 10:00	Thomas Conrad	tmc@add-on-company.com

Name	Visitor Type	Location	Zone	Authorization	Message
Kimberly Jackson	Consultant	Locations\US\New York		Awaiting	
			Conference Zone	Awaiting	
			Showroom Zone	Authorized	
			Developers Block	Awaiting	

You can review your visitor registrations in your 'My Meetings' in Outlook.

Figure 180. Notification email to visitor authorizer

NOTE: This email will still be sent to organizer even if there are zone(s) or location(s) that are in 'Pending' status.

Notification email to the Host

If the organizer designates a Host (the organizer and the Host must be 2 different persons), the Host will receive notification email when the visitors are authorized, e.g.:

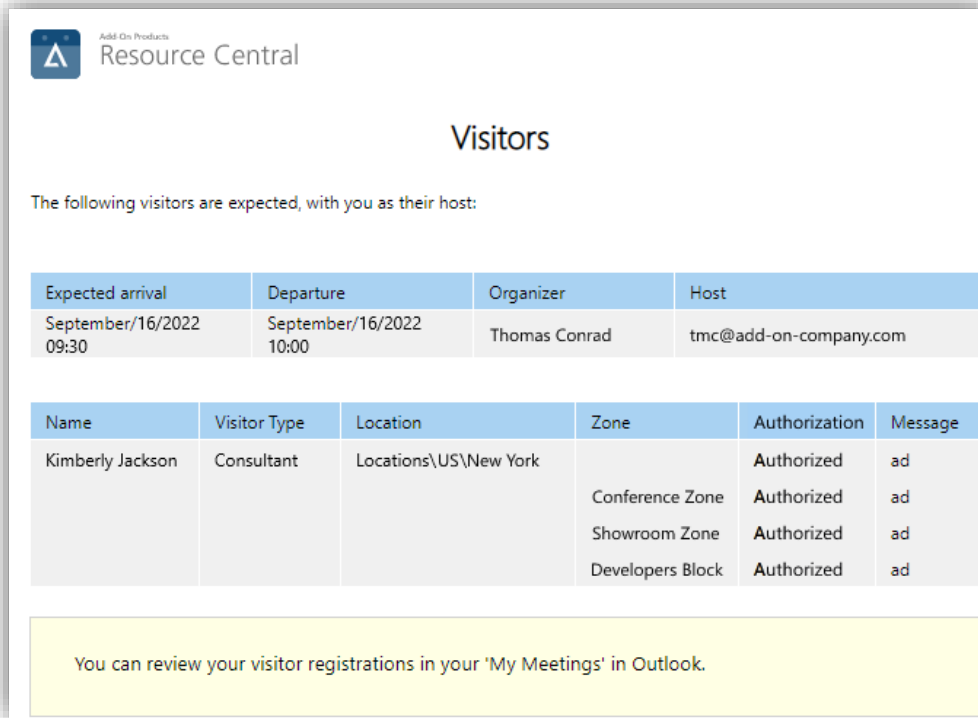

Figure 181. Notification email to the Host when visitors are authorized

NOTE: This email will only be sent to the Host if all zones & locations are no longer in 'Awaiting' status.

This email aims to inform the person that he/she is designated as a Host to the shown visitors. If there are multiple visitors in the visit, they will all be included in the notification email above.

And when the visitors arrive, another notification email will be sent to the Host to inform him/her of their arrival. E.g.:

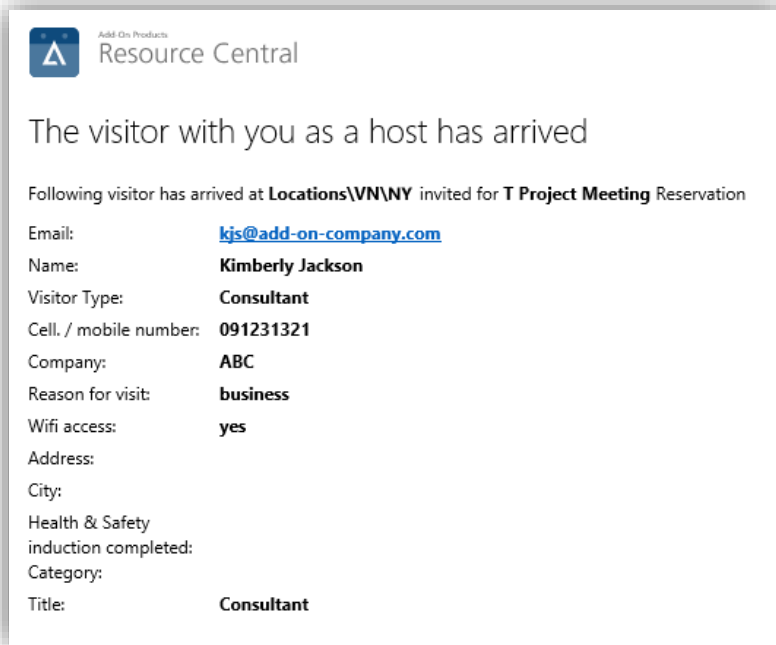

Figure 182. Notification email to the Host when visitors arrived

If there is no Host added, or the Host and the organizer are the same person, then this email will be sent to the organizer.

Signage

From this node, you can manage all entries related to the Signage. You can create/update/delete any kind of entries with this module. When you select the Signage node, the following screen will appear:

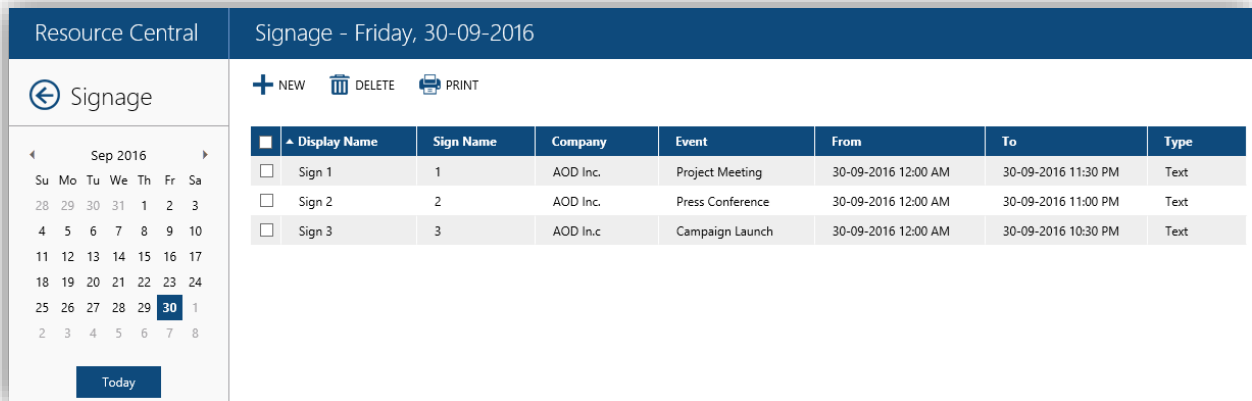

Figure 183. Signage Summary screen

The screen date is populated as per the date selected on the calendar. When the Digital Signage Export is executed, all the corresponding listed entries will also be listed in the generated output XML. Moreover, you cannot create a Conflicting Entry for a 'Sign Name'. If you accidentally try to do so, the following error message is displayed:

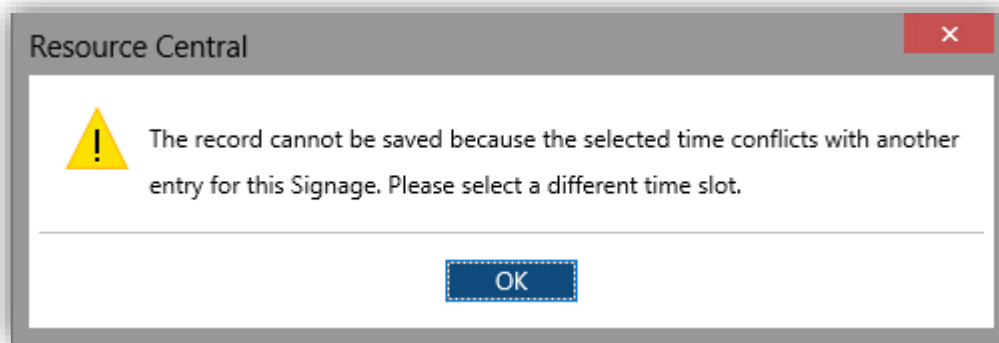

Figure 184. Time duration conflict message

NOTE: Reservations of Light Resources will neither be listed at this screen nor imported into the XML

Toolbar Buttons	Description
New	You can create a new visitor
Delete	You can delete the selected records
Search	The criteria mentioned in this text box will only be applied over the Display Name and Sign Name Column values. All those entries that meet the criteria will be listed

There are two types of entries: Text and Booking. Both will be discussed as follows.

Booking type entries

Booking type entries are only associated with the reservations over physical Exchange resources. Reservations that have all the signage related information would be listed here. For more information on how to create such entries, please refer to [Chapter 6 – Digital Signage Integration](#) in this document.

- If user **clicks** to see the details of any of the Booking type entries, then all the fields will be Read Only except the 'Company' and 'Event' fields.
- If user **makes changes** to the data of the Booking type entries, then email is routed to the organizer of that reservation, intimating him/her about the changes. Also, when the organizer views the order form again for that reservation, those changes are reflected in the order form.
- If user **deletes** any of the listed Booking type entries, then email is routed to the organizer of that reservation, intimating him/her that the Signage information has been deleted. Also, when the organizer views the order form again for that reservation, the corresponding Signage property values are cleared from the Order form.

NOTE: Only Booking Type entries lying in the future are listed here. If the date/time of any of the Booking type Signage entry is passed, it will neither be listed at this screen nor will be imported into the XML.

Text type entries

Text type entries are those created using the controls available over the **Daily Tasks → Signage** section. You can create new entries, update the existing entries, and delete any kind of entries.

When you click upon any of the listed entries, the details of that entry are displayed:

Figure 185. Signage details screen

Field	Description
Display Name	Editable text box field. When the Lookup value from the Sign Name is selected, then the Lookup → Name value is displayed here. However, you can change it afterwards.
Sign Name	Non-editable Lookup field. The Lookup will display all those Lookup values that have been created with Table name = Signage. The value in this field will be displayed in the 'Roomname' & 'Templatenamename' tags in the XML while Signage entry = Text. For Signage entry = Booking, the value of the 'Sign Name' field in the respective resource detail will be displayed
Company	Text box: The value in this field will be displayed in the 'Companyname' tag in the XML
Event	Text box: The value in this field will be displayed in the 'Eventname' tag in the XML
Date	Calendar control. By default, the current date is selected.
Time From	Non-editable Lookup field. The Lookup will display the timeslots with the difference of 1 minute. The value in this field would be displayed in the 'Starttime' tag in the XML.
Time To	Non-editable Lookup field. The Lookup will display the timeslots with the difference of 1 minute. The value in this field will be displayed in the 'Endtime' tag in the XML

Toolbar Buttons	Description
Save	Save all your changes to the Signage entries
List	Take you back to Signage detail screen

Tasks

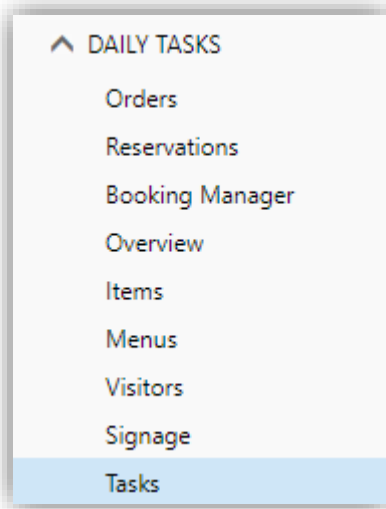

Figure 186. "Tasks" menu item

For **Shared Order 1.0** feature, there is a new menu item under **Daily Tasks**.

Shared Order 1.0 feature is an additional function of the Resource Central system, which allows organizers to book multiple resources which have the same order form assigned. This order form is labeled "Shared Order Form" (SOF). The booking is handled by a Service Desk Agent (SDA) (belonging to a group) and the information flow between organizer and the SDA is controlled by the content of the SOF.

For more details about setting up this feature, refer to [Steps for Administrator to set up Roles, create Properties and Design Shared Order Form for Shared Order 1.0 feature](#) section.

Only Shared Orders are managed by this menu item **Tasks**, normal orders are still maintained in **Orders** menu item.

The tasks are listed based on the role(s) of the logged in user. When the user (as an SDA) logs in, he will see tasks assigned to him.

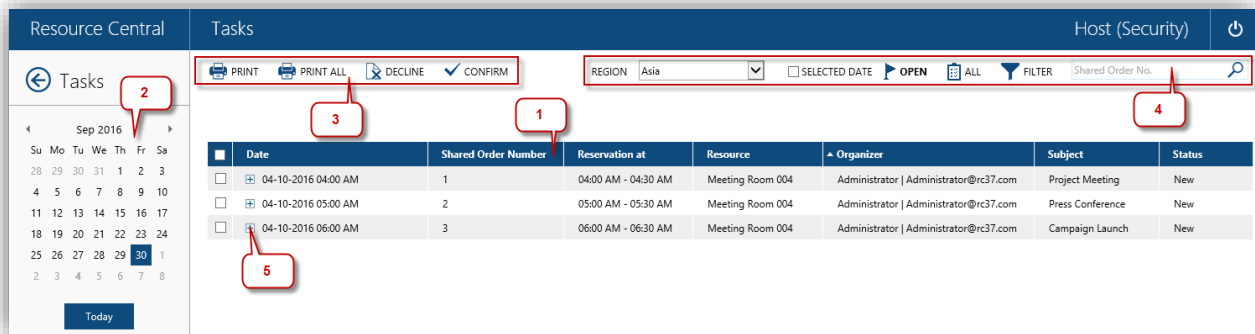

Figure 187. Tasks menu item

1) Order Row

- Date** The date the meeting will take place.
- Shared Order Number** ID of Shared order
- Reservation at** Format of date/time/serving time is based on format used by the logged-in person.
- Resource** The resource name of the appointment. For bookings that contain multiple resources, the last one will be displayed.
- Organizer** The name of the organizer.
- Subject** The subject of the appointment.



Status

The status of the order.

As the status is actually on each property value, the shown status is the lowest status property values contained in the shared order. This is described under **Order Status**.

2) Calendar

This calendar works if option "Selected date" is checked in **Filter buttons** section (4). The date selected by default is current date.

3) Action Buttons

Print

Prints the selected orders.

Print all

Prints all orders

Decline

Declines the selected Order. Only one Shared order can be declined at a time. If you select multiple rows, then a warning message will be shown, and you cannot click [**Decline**].

You can only decline Tasks with status New, Changed or Confirmed.

Confirm

Confirm the selected Order.

The order status will be changed to Confirmed and the organizer will receive a confirmation email.

It's possible to confirm one or many Shared orders at the same time. You can only confirm Tasks with status New, Changed or Declined.

4) Filter buttons:

Search

Search Shared Order by entering the Shared Order Number and click the magnifier icon.

Region

Select region to work on from the dropdown list.

Selected date

Check to view orders in the date selected in Calendar on the left menu of the screen.

Open

Show all open orders.

Open orders are orders with status **New**, **Changed** or **Deleted** and **unassigned** or **assigned** to the current user. (Deleted is included because these orders can be prepared a long time ahead, so they also need to take action on orders that are deleted.)

All

Show all orders, considering the other filters that may have been applied.

Filters

Filter by status. A pop-up window appears for you to select status(es) to filter.

5) Plus sign:

Expand Orders

The plus sign expands the order and shows all the Property values of Shared order Form

The property values must be listed, according to the role(s) of the logged in user, i.e., that user will only see Properties that has been attached to the specific role or has been marked as "**Send to All**".

Reports

In the Reports section you will find a number of reports used for viewing **statistics** and **order** information.

Standard Reports

In all of the reports discussed below (except the 'Resource Utilization' & 'Week Planner' reports), you will find that four Location fields provided in Report Condition section are optional. These fields enable you to view the data of only resource(s) lying at the same absolute location(s) and its children that you have specified in the input.

If you opt to run the report, without selecting any location, the corresponding output will be based upon the records of only resource(s) lying at the same location as that of your absolute location(s) and its children.

When the result of the report shows up, you can select export options from the  (floppy disk) icon. There are 3 options: PDF, Word, Excel, of which PDF is always available and 2 other options must be enabled by corresponding parameters.

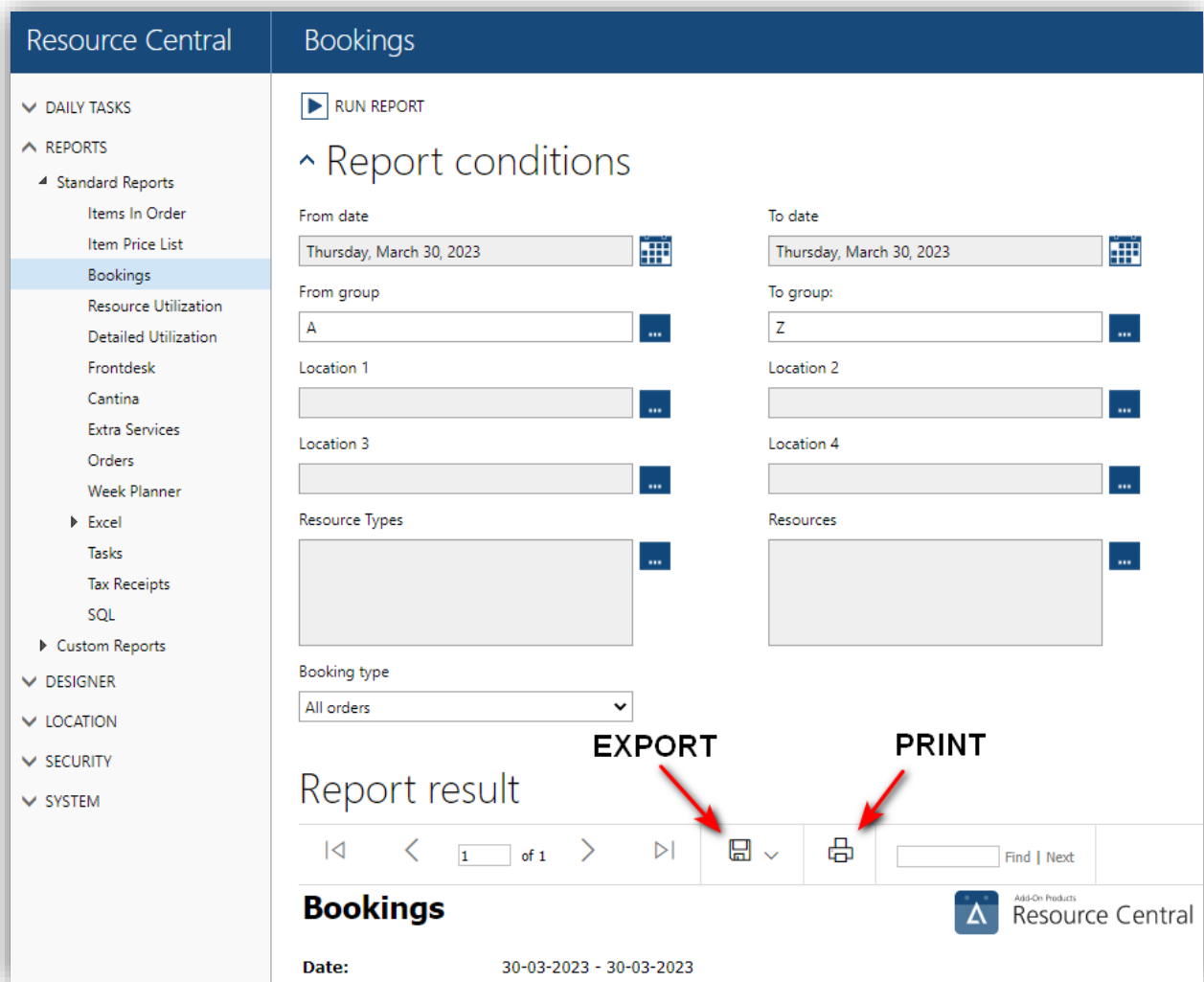

Figure 188. Bookings report

NOTE: The logos on the reports and on the RC login screen are all the same. In reports, it can be changed with images of the same size – 115px x 38px (width x height) or images with the same ratio. If you want to add your own logo, see the description of Main Logo in [Basic Parameters](#) section.

If there is no data for the date(s) you selected to run the report, there is a message to notify that for each report located at the **Report result** area.

For example: This is the message if there is no data for selected date(s) in Bookings report:

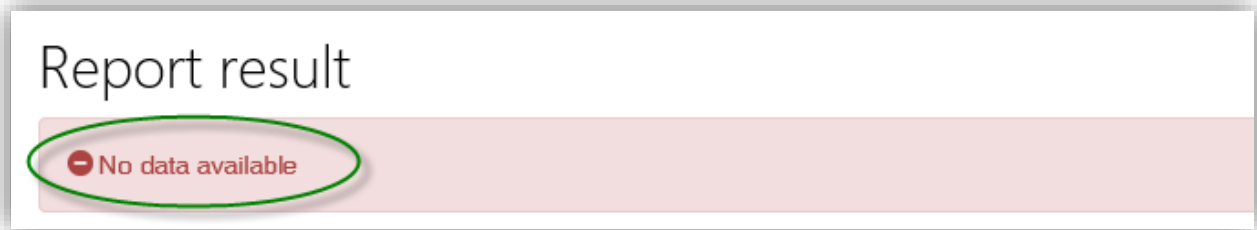

Figure 189. “No data” message

The list of standard reports is as follows:

- [Items in Order](#)
- [Item Price List](#)
- [Bookings](#)
- [Resource Utilization](#)
- [Detailed Utilization](#)
- [Visitor Emergency Report](#)
- [Frontdesk](#)
- [Cantina](#)
- [Extra Services](#)
- [Orders](#)
- [Tasks](#)
- [Tax Receipts](#)
- [Week Planner](#)
- [Excel](#)
- [SQL](#)

Items in Order

Reports the **items in order** for a reservation. Items may be repetitive in an order (as in case of multiple servings), and there could be multiple orders for a given day for different resources. So, in all these cases, the total quantity and the total price for an item are displayed in the report on daily basis.

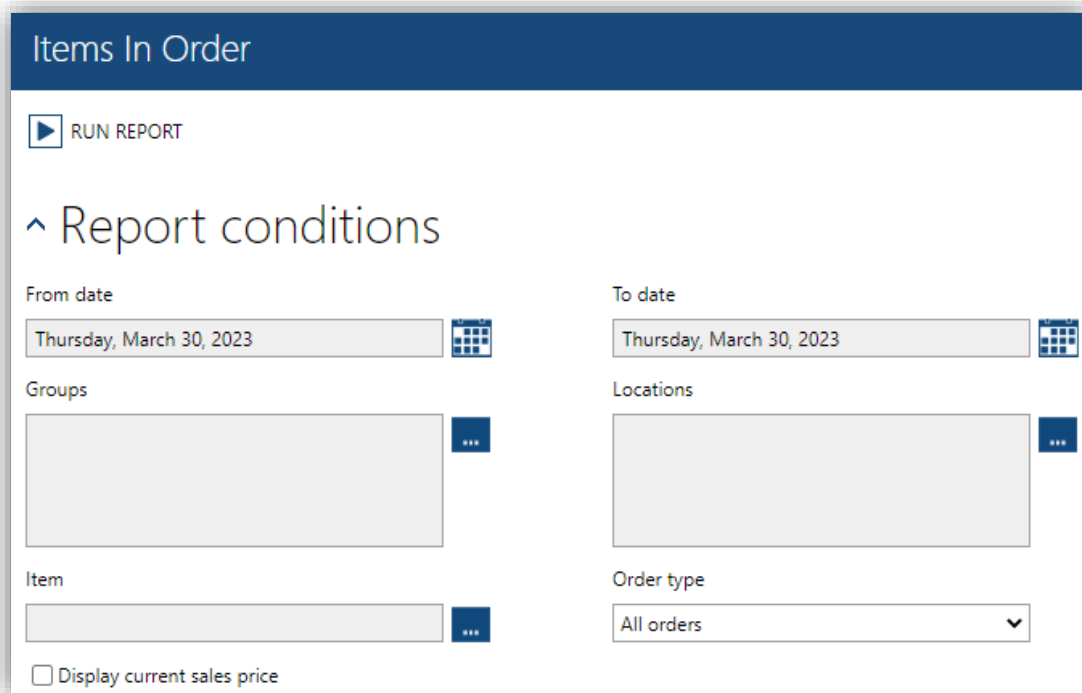

Figure 190. Items in order report



Based on the **selected criteria**, items in an order are presented with order of **item group**. Within an individual group, they are ordered by date. When “**Run Report**” button is clicked, the criteria work in the following manners:

- If no data exists against the specified criteria, nothing will be displayed
- If same dates are given in ‘From date’ and ‘To date’ then the report result will be data of the whole selected date
- When same letter is given in ‘From group’ and ‘To group’ then all the groups with the letter as the starting letter of their names are displayed in the report
- When different letters are given in ‘From group’ and ‘To group’, then all the groups having the specified letters as the starting letter of their names and all the alphabetical letters in between are shown in the report.
- If digits or numbers are specified in the group criteria, either same or different then the output for existing data having the specified digit/number as the starting character of their names and all those digits or numbers in between are shown in the report.
- When you select “**Item**” filter, clicking [...] button will only show items that have been booked, i.e., items that are not booked in any orders will not be displayed.

Field	Description
From date	Starting Date to extract data
To date	Ending Date to extract data
Groups	Letter, digit/number, or name of the groups
Locations	Select locations to filter
Item	Select booked items from the list to filter
Order type	Select type of orders to be displayed
Display current sales price	Include current sales price of each item in the report

Toolbar Buttons	Description
Run Report	Executes the criteria mentioned and displays the report

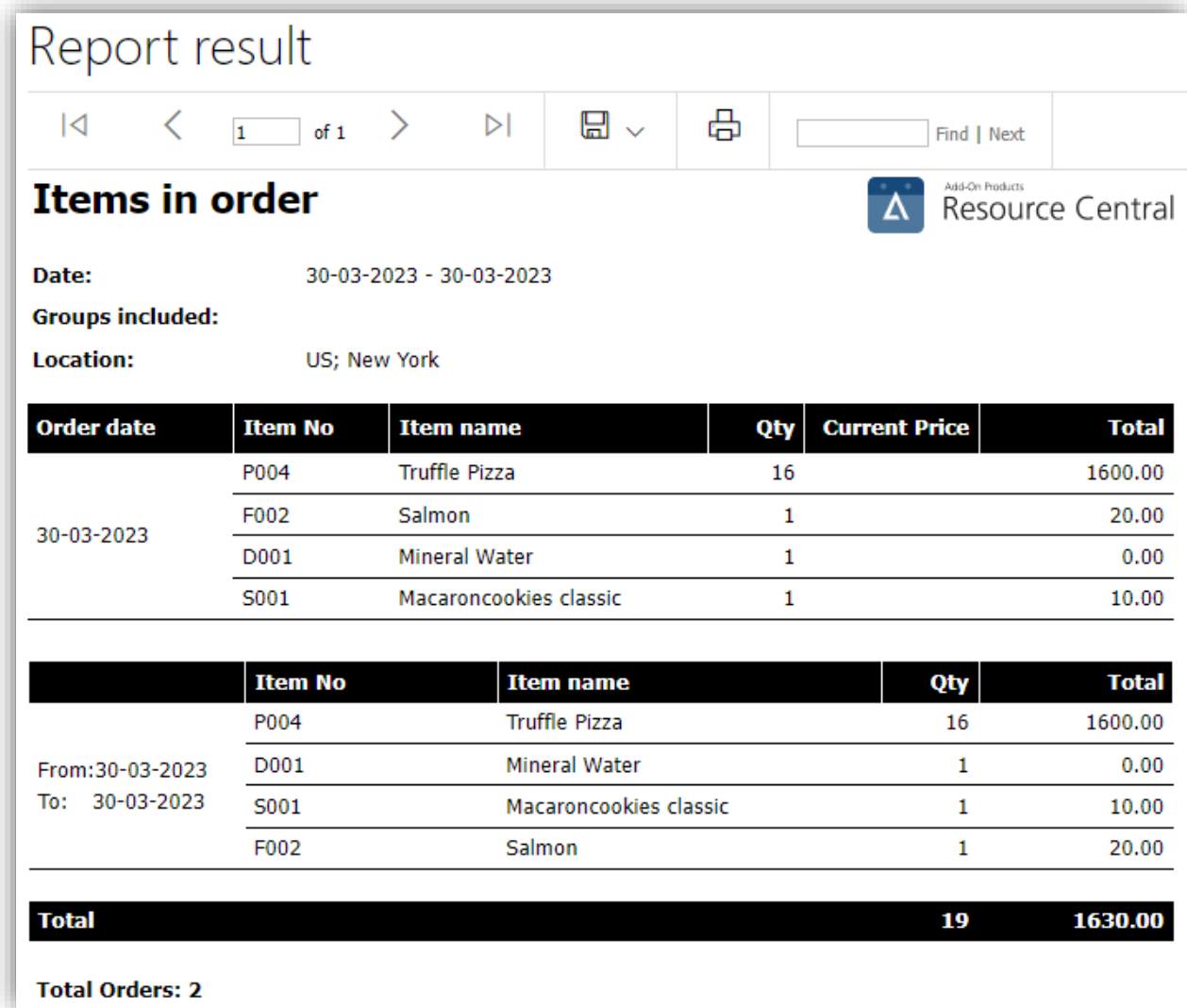

Figure 191. Items in order - output

This report will not take the orders which have status **Declined** (status id = 3) or **Deleted** (status id = 8) into account.

If the order has status **Confirmed** (status id = 2), **Arranged** (status id = 5) or **Locked** (status id = 7) then the price will be calculated based on **ReturnableQty** field, but if this field is empty then the value in **Quantity** field is returned. In other cases, it is calculated based on **Quantity** field.

The result table will show orders & items based on the specified **Groups** and **Locations**. Regardless of the condition, the result table will include 2 parts:

- The first part displays each order based on their date and their respective items.
- The second part displays the total items across all orders above within the specified **From – To** date, e.g.:

	Item No	Item name	Qty	Total
	P004	Truffle Pizza	16	1600.00
From:30-03-2023	D001	Mineral Water	1	0.00
To: 30-03-2023	S001	Macaroncookies classic	1	10.00
	F002	Salmon	1	20.00
Total			19	1630.00

Total Orders: 2

Figure 192. Items in order – total orders & items

NOTE:

1. This report does not include menus into the Group total calculation.

Menu2	Item No	Item name	Qty	Total
15-09-2017	2	Menu2	7	42.00
	4	Menu 4	8	48.00
	5	Menu 5	9	54.00
Group total			0	144.00

2. If an order has an item/menu with **editable Sales price** (refer to [Item details](#)), that item/menu's Current price will be hidden on the report. Also, that item/menu will be put in a separate line. E.g.:

Items in order

Add-On Products
Resource Central

Date: 02/15/2023 - 02/15/2023

Groups included: Snacks Food; Snacks menu

Location:

Snacks Food	Item No	Item name	Qty	Current Price	Total
02/15/2023	MCR3	Macaroncookies	2		-10.00
	MCR3	Macaroncookies	4	5	20.00

In the example above, the item 'Macaroncookies' on the first line has its price edited, unlike the item of the same name on the second line which does not have its price changed.

3. If an order has an item/menu with **its name edited** (refer to [Item details](#)), the report will show its edited name instead of the original one. Also, that item/menu will be put in a separate line. E.g.:

Items in order



Date: 02/15/2023 - 02/15/2023
Groups included: Snacks Food; Snacks menu
Location:

Snacks Food	Item No	Item name	Qty	Current Price	Total
02/15/2023	MCR3	Macaroncookies	2		-10.00
	MCR3	Macaroncookies special with extra coconut	3		15.00

In case there are multiple orders that have edited items/menus with the same name or price, they will be considered the same item/menu and included the same line on the report.

Item Price List

This report shows the price list of those items which appear in the orders created in the selected date range.

Item Price List

Report conditions

From group

To group

Location 1

Location 2

Location 3

Location 4

Include inactive items

Include menu content

Choose the columns you want listed in the report:

Group
 Number
 Name
 Cost price
 Sales price
 Status

Figure 193. Item Price List – report conditions

Among the check boxes under “**Choose the columns you want to see in the report**”, each of 4 columns (**Number, Name, Cost price, Sales price**) will appear in the report result if the check box next to each of them is checked.

Operation of the **Group** box selection is as follows:

- If Group box is checked: Items in the report result are grouped by Group Name alphabetically.

Choose the columns you want listed in the report:

Group Number Name Cost price Sales price Status

Report result

1 of 1

Item price list

Groups: A - Z
Location:

Name	Cost price	Sales price	Status
Drinks			
Coffee	7.00	5.00	Active
Tea	10.00	8.00	Active
Food			
Cake	12.00	8.00	Active

Figure 194. Report result – Group checked

- If Group box is unchecked: Items in the report result are first sorted by Sort Order of each item, then they are sorted by the first selected columns in the 4 latter columns in “**Choose the columns you want to see in the report**” condition.

Choose the columns you want listed in the report:

Group Number Name Cost price Sales price Status

Report result

1 of 1

Item price list

Groups: A - Z
Location:

Name	Cost price	Sales price	Status
Coffee	7.00	5.00	Active
Cake	12.00	8.00	Active
Tea	10.00	8.00	Active

Printed 30-09-2016 03.09 Page 1 of 1

Figure 195. Report result – Group unchecked

NOTE: Group, Name, Sales price, and Status are selected by default.

Bookings

This report shows the bookings for a resource. By giving the date range or specifying the group range, the report shows the Bookings of a resource for respective days.

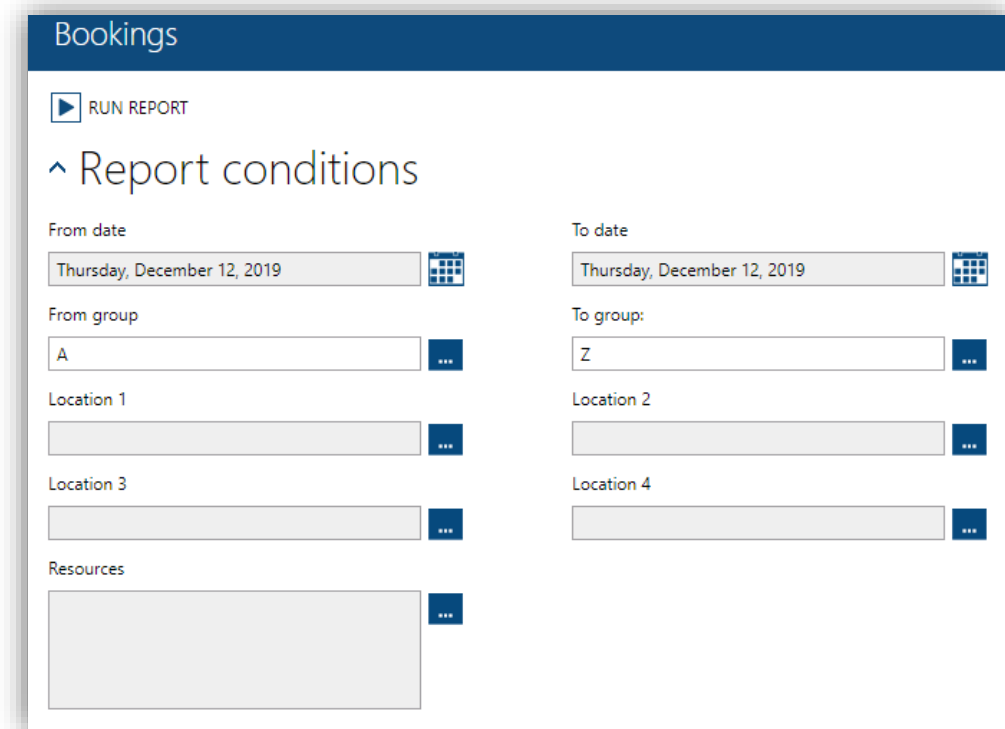

Figure 196. Bookings report

Based on the selected criteria, bookings are presented **ordered by resource** group and within a group they are ordered by date. The criteria work in the following manner:

- If same/different dates are given in 'From date' and 'To date' then the report will be shown according to the specified criteria
- When same letter is given in 'From group' and 'To group' then all the groups with the letter as the starting letter of their names are displayed in the report
- When different letters are given in 'From group' and 'To group', then all the groups having the specified letters as the starting letter of their names and all the alphabetical letters in between are shown in the report
- If digits or numbers are specified in the group criteria, either same or different then the output for existing data having the specified digit/number as the starting character of their names and all those digits or numbers in between are shown in the report.

Field	Description
From date	Starting Date
To date	Ending Date
From group	Letter, digit/number or the name of the group
To group	Letter, digit/number or the name of the group

Toolbar Buttons	Description
Run Report	Execute the criteria mentioned and displays the report

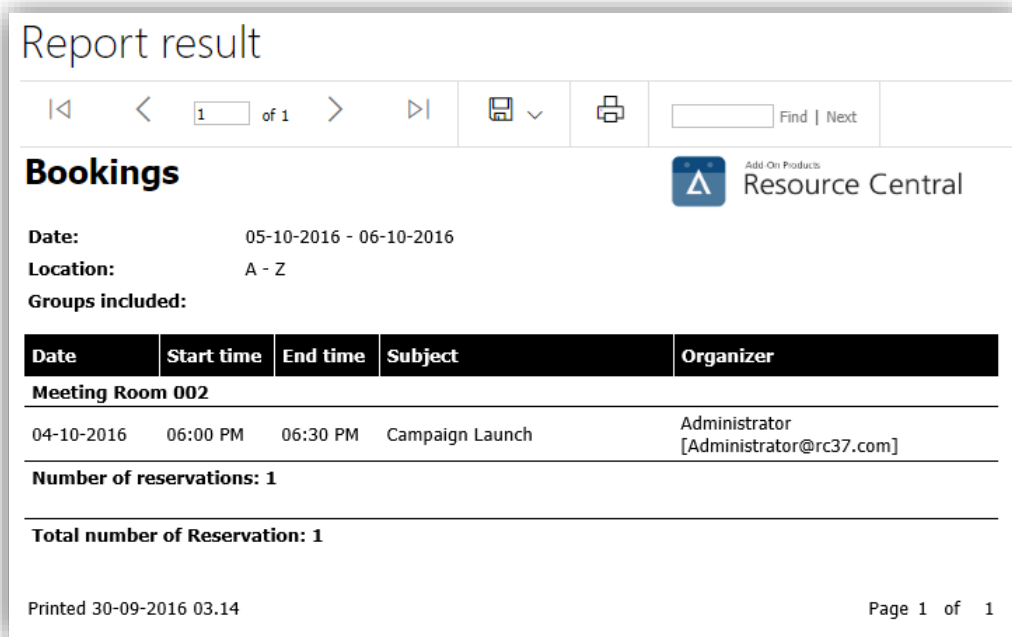

Figure 197. Bookings - report

Resource Utilization

Reports the utilization of a resource for a day or a date range as specified. The utilization is shown in terms of percentage which is calculated as the usage of a resource for a number of hours in split hours range.

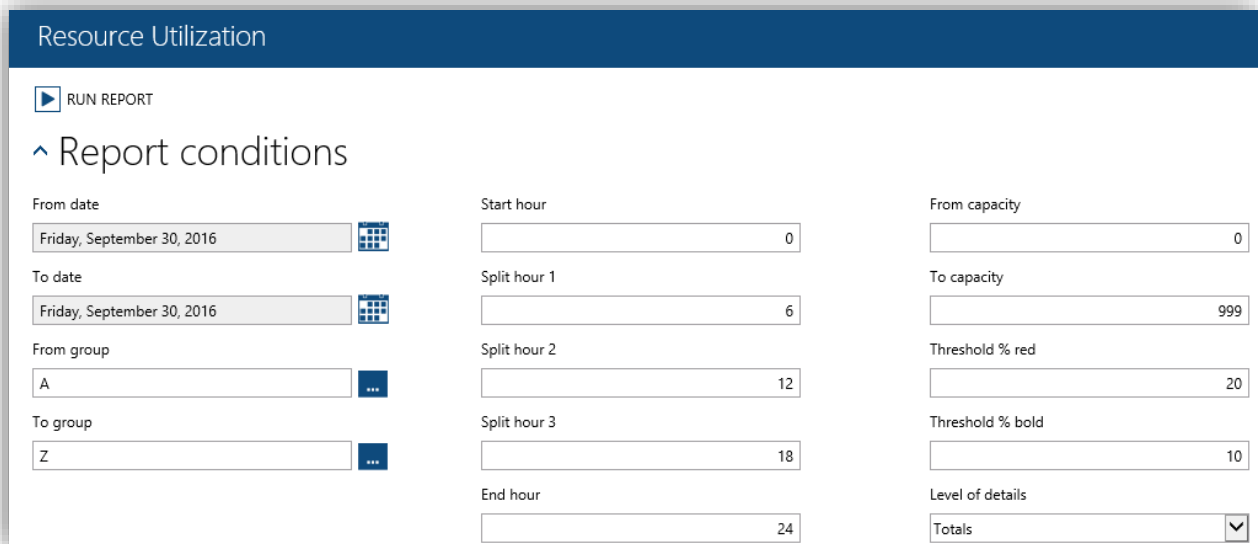

Figure 198. Resource utilization report

Field	Description
From date	Starting Date
To date	Ending Date
From group	Letter or the name of the group
To group	Letter or the name of the group
From capacity	The no. of persons that the resource can accommodate

To capacity	The no. of persons that the resource can accommodate
Level of details	Have 2 values from which one can be selected at a time; 'Totals' & 'Groups included'
Start hour	The initial hour to start splitting the time range with (mandatory field)
Split hour 1	Initial hour to the hour mentioned here (mandatory field)
Split hour 2	Split hour 1 to the hour mentioned here (mandatory field)
Split hour 3	Split hour 2 to the hour mentioned here (mandatory field)
End hour	Split hour 3 to the hour mentioned here (mandatory field)
Threshold % red	Marks the percentage red above the threshold mentioned
Threshold % bold	Marks the percentage bold above the threshold mentioned

Toolbar Buttons	Description
Run Report	Execute the criteria mentioned and displays the report

Based on the selected criteria, you are able to **filter and group the reservation(s)** showing the **utilization** in given time intervals, highlighting **intervals with red or bold** if the utilization is above the threshold value.

- If you run the report with “**Level of details = Totals**” (as shown above), the output of the report will display the utilization percentages, against each timeslot, with respect to the Total Number of Resource(s) in the specified group range.

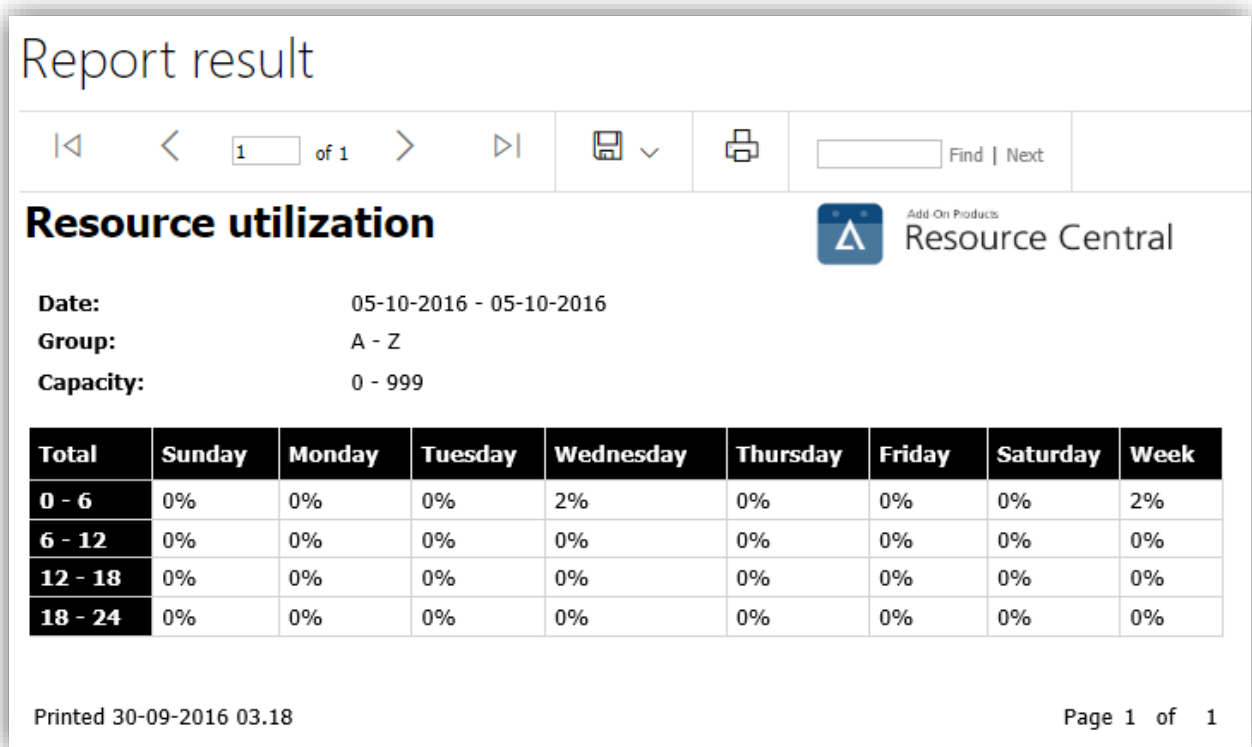

Figure 199. Resource utilization report - Totals

NOTE: If there are resources on which no reservations exist, their impact will still be catered in the output of the report.

- If you run the report with “**Level of details = Groups included**”, the output will display the utilization of the resource(s) individually for each group, along with the Total of all the groups at the end. An example is as follows:

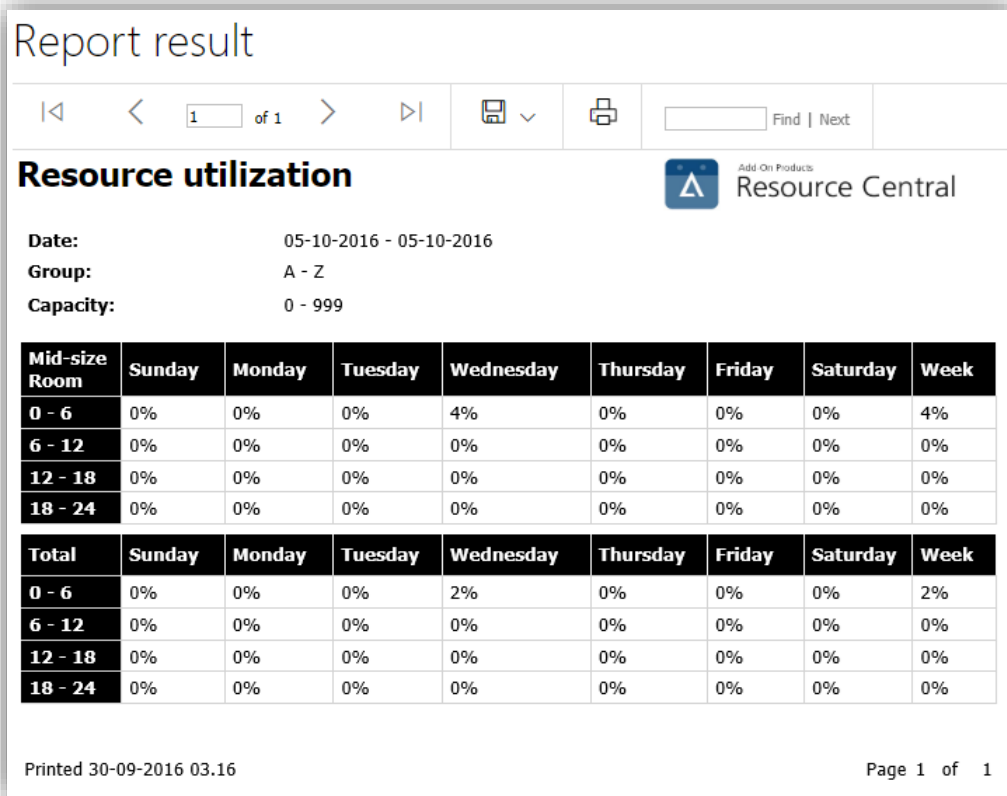

Figure 200. Resource utilization report – Groups included

As you can see in the above screen, the individual breakup of the Groups has been displayed along with the Totals, representing the complete utilization of the involved resources.

- The dates mentioned in **From date** and in **To date** are start date and end date of the criteria/range or reservation. When they are the same, report will be shown for a particular day, or else for the complete date range.
- The report will always display the utilization of a particular timeslot in percentages, with respect to the total number of resources in the specified group range. The displayed percentages in the Day/Week column(s) are calculated based on the following formula:

$$\frac{\text{Sum of Total hours used in a time slot by each resource}}{\text{No. of resources in concerned group(s)} \times \text{Total days} \times \text{Total hours in concerned time slot}} \times 100$$

Sum of Total hours used in a time slot by each resource	It will be calculated by adding all duration spent on each resource
No. of resources in selected group range	Based on the value selected in From group and To group : For a specific group result: Total number of resources in that group (Virtual resources will be taken into account if they are in the concerned group). For total result: Total number of all resource in selected group range (Virtual resources will not be taken into account).
Total days	Total days calculated based on selection made in From date and To date fields.

	<p>NOTE:</p> <ul style="list-style-type: none"> - With Date result, it is total occurrence of that date in the selected date range. - With Week result, it is total date of the selected date range.
Total hours in concerned time slot	Duration between the start and ending moment of the selected time slot

For example:

There are 6 resources (resource 1 → resource 6) in the system: Group1 contains 4 resources (resource 1 → resource 4), Group2 contains 1 resource and Groups 3 contains 1 resource.

A reservation is booked from 18:00 – 18:30 (**0.5h**) on March 18, 2013, and another reservation is booked from 19:30 – 21:00 (**1.5h**) on March 19, 2013, on resource 1. (Then, if there are 2 time slots, say 10 – 18 and 18 – 24, then the concerned time slot is 18 – 24, and **Total hours in concerned time slot** is **6**).

Open Report From date = 18/3/2013, To Date = 19/3/2013.

Value in **From group = A; To group = Z**.

Select "**Groups Included**" in **Level of details**.

Based on the earlier mentioned formula, result of utilization report for resource 1, time slot 18 – 24 is:

Group result:

$$\text{Date result} = \frac{0.5}{4 \times 1 \times 6} \times 100 = 2\% \text{ (for March 18, 2013)}$$

$$\text{Date result} = \frac{1.5}{4 \times 1 \times 6} \times 100 = 6\% \text{ (for March 19, 2013)}$$

$$\text{Week result} = \frac{0.5+1.5}{4 \times 2 \times 6} \times 100 = 4\%$$

Total result:

$$\text{Date result} = \frac{0.5}{6 \times 1 \times 6} \times 100 = 1\% \text{ (for March 18, 2013)}$$

$$\text{Date result} = \frac{1.5}{6 \times 1 \times 6} \times 100 = 4\% \text{ (for March 19, 2013)}$$

$$\text{Week result} = \frac{0.5+1.5}{6 \times 2 \times 6} \times 100 = 3\%$$

Detailed Utilization

The Detailed Utilization is designed to provide an overview of the utilization percentage of the resources and resource groups in the system. It is enhanced in comparison with the standard Resource Utilization Report so that user can see utilization percentage of each resource based on preferred conditions.

When you select the "**Detailed Utilization**" node in the tree view, the following screen of the report will appear:

The screenshot shows the 'Detailed Utilization' report configuration interface. It features a 'RUN REPORT' button at the top left. Below it is the 'Report conditions' section, which is expanded. The configuration options include:

- From date:** Friday, September 30, 2016
- To date:** Friday, September 30, 2016
- Location:** (Empty text field)
- Group:** All (Dropdown menu)
- Resource:** All (Dropdown menu)
- Upper threshold (%):** 80
- Lower threshold (%):** 20
- Include weekend days:**
 - Saturday
 - Sunday
- Resource opening hours:** (Selected)
- Specify hours:** (Not selected)
- Start time:** 12:00 AM (Dropdown menu)
- End time:** 12:00 AM (Dropdown menu)

Figure 201. Detailed Utilization report

The percentage is calculated based on the following formulas:

a) Selected method: Resource opening hours

The formula for each resource:

$$\text{ResourcePercentage} = \frac{[(\text{number of booked hours in the time range}) / (\text{total opening hours of the resource in the time range})] \times 100\%}{}$$

and for Group:

$$\text{GroupPercentage} = \frac{[(\text{total booked hours for a group in the time range}) / (\text{total opening hours of this group in the time range})] \times 100\%}{}$$

In which:

+ Total booked hours for a group in the time range is sum of booked hours of every resource in this group in this time range and in the selected location.

+ Total opening hours of this group in the time range is total opening hours of every resource in the time range and in the selected location.

NOTE: If Saturday and/or Sunday are excluded (unchecked in the condition selection), the booked hours and opening hours in the formulas are accordingly excluded.

b) Selected method: Specify hours

The formula for each resource:

$$\text{ResourcePercentage} = \frac{[(\text{number of booked hours in the time range}) / ((\text{Total hours of (End Time - Start Time)}) \times \text{total days})] \times 100\%}{}$$

and for Group:

$$\text{GroupPercentage} = \frac{[(\text{total booked hours for a group in the time range}) / ((\text{Total hours of (End Time - Start Time)}) \times \text{total days})] \times 100\%}{}$$

In which:

Start Time and **End Time** are in proportion to “Start” and “End” time specified in “Start Time” and “End Time” fields in the report condition area.

Select specific conditions to run the report based on your preferences. Then click [**Run Report**] button, the result is displayed as shown in the figure below:

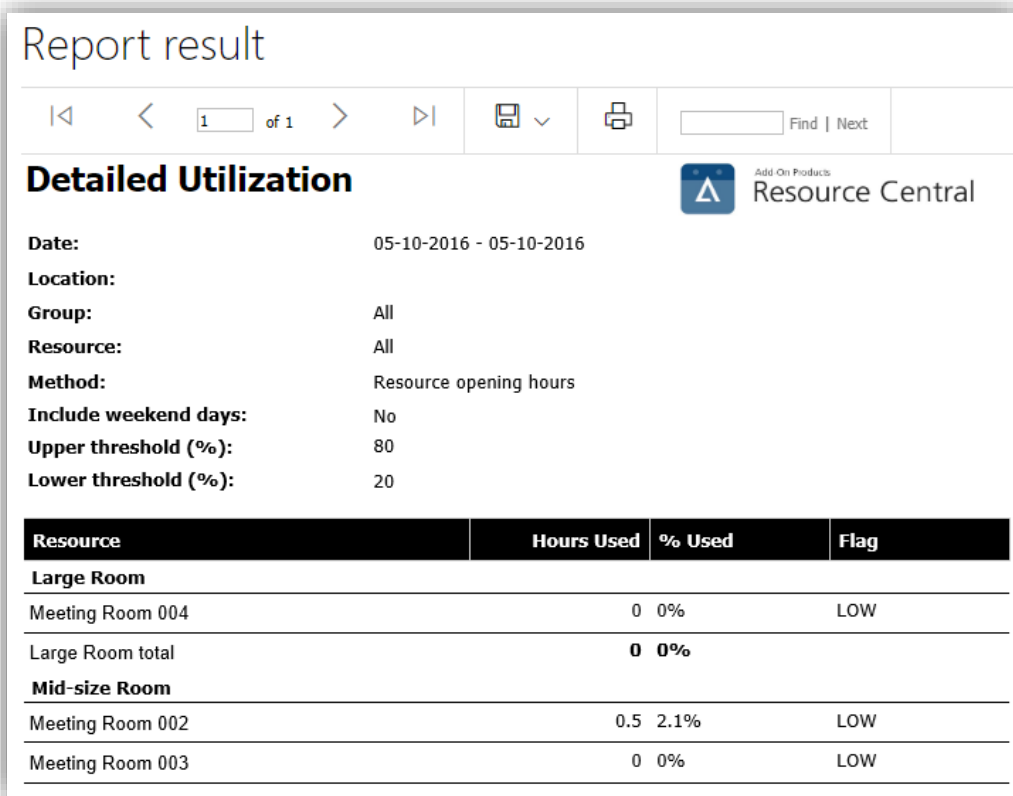

Figure 202. Report result

NOTES:

- The upper and lower thresholds must be in the range of 0 to 100%.
- The upper threshold must be greater than the lower threshold.
- Values in upper and lower thresholds must be positive integer.

Based on the percentage filled in “**Upper threshold**” and “**Lower threshold**”, the result is categorized into LOW and HIGH:

- Percentages larger than and equal to the value filled in “**Upper threshold**” are categorized as HIGH.
- Percentages smaller than and equal to the value filled in “**Lower threshold**” are categorized as LOW.
- Percentages in between are blank.

Visitor Emergency Report

Besides running the emergency reports in **Daily Tasks** → **Visitors**, you can run them under **Standard Reports** with the purpose of viewing a list of visitors who have currently checked in and still remained in a location on selected day.

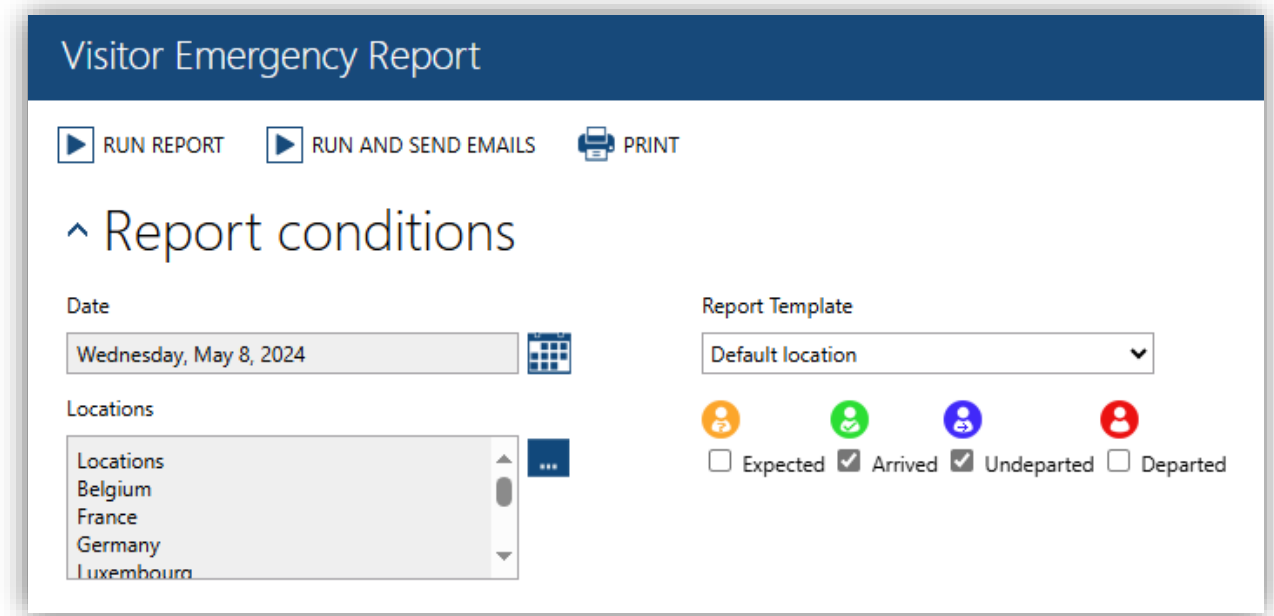

Figure 203. Emergency Report

You can select any date for which you want the summary as per Visitors. The report can only run for a single date.

Toolbar Buttons	Description
RUN REPORT	Execute and display the report for the selected date
RUN AND SEND EMAILS	Execute and display the report for the selected date and send reports to the email recipients configured on visitor emergency report template. For more details on how to manage email recipients to whom Visitor Emergency Report will be sent, refer to this section
PRINT	Print the report result

Field	Description
Date	Calendar control by the help of which you can select a date on which you want to run the report
Location	Select the location for the report. The location must be defined in 'Location' tree under Location node
Report Template	Selection between the pre-made templates for the emergency report. To create report templates, refer to this section for configurations

Checkboxes	Description
Expected/Arrived/Undeparted/Departed	Status of the visitor. The default Statuses are "Arrived" and "Undeparted". The report will only export visitors with the selected states.

After selecting the date, location(s), and other desired conditions, you click the “Run Report” button at the toolbar, in the right pane, following which the report will be displayed at the same screen, as shown below:

Report result

Visitor Emergency Report



Date: 2024/05/08
Locations, Belgium, France, Germany, Luxembourg, Netherlands, Scandinavia / Nordics, Switzerland, UK, USA, Canada, Dubai, Australia, Bruxelles, Hasselt, Paris, Bâtiment, Hamburg, Building 8, Building 16, Frankfurt / Main, Floor 12, Munich, Berlin, Campus 2, City Center, Amsterdam, Rotterdam, Danmark, Norge, Sverige, Finland, København, Vejle, Oslo, Bergen, Stockholm, Malmö, Helsinki, Espoo, Basel, Geneva, Zürich, London, Building 1, Building 2, Meeting Rooms, Hot Desks, New York, Los Angeles, Building 1, Building 2, Toronto, Vancouver, Dubai, Canberra, Perth, Sydney, VietNam,

Locations:

Locations

Name	Title	Email	Location	Visitor ID	Organizer/Host	Resource name	Departure Time
Host1		ad1@ad.ad	Locations\Ngoc test\Ngoc Test A ap	000000004798	Host1	N1 Meetingroom Bruxelles RC1_011 (Ngoc test)	07:00
Host1		ad1@ad.ad	Locations\Ngoc test\Ngoc Test A ap	000000004790		N1 Meetingroom Bruxelles RC1_011 (Ngoc test)	20:00
Host1		ad1@ad.ad	Locations\Ngoc test\Ngoc Test A ap	000000004804		N1 Meetingroom Bruxelles RC1_011 (Ngoc test)	07:00

Locations\Australia

Name	Title	Email	Location	Visitor ID	Organizer/Host	Resource name	Departure Time
Host1	2345	theu1@gmail.com	Locations\Australia	000000004856	Simon Fisker Seren Skau	Seren 1	07:00
department 1	new badge	theu1@gmail.com	Locations\Australia	000000004922	Department 1		13:55
Host1	new badge	theu1@gmail.com	Locations\Australia	000000004923	Department 1		18:45
Host1	new badge	theu1@gmail.com	Locations\Australia	000000004928	Department 1		15:04
Host1	new badge	theu1@gmail.com	Locations\Australia	000000004924			22:45

Figure 204. Report result

Click **[Run and send emails]** to export and send the report result to preset emails.

Front Desk

The Front Desk Report is designed to provide an overview of a reservation with respect to the Registered Attendees in that reservation.

When you select the “**Frontdesk**” node in the tree view, the following screen of the report will show up:

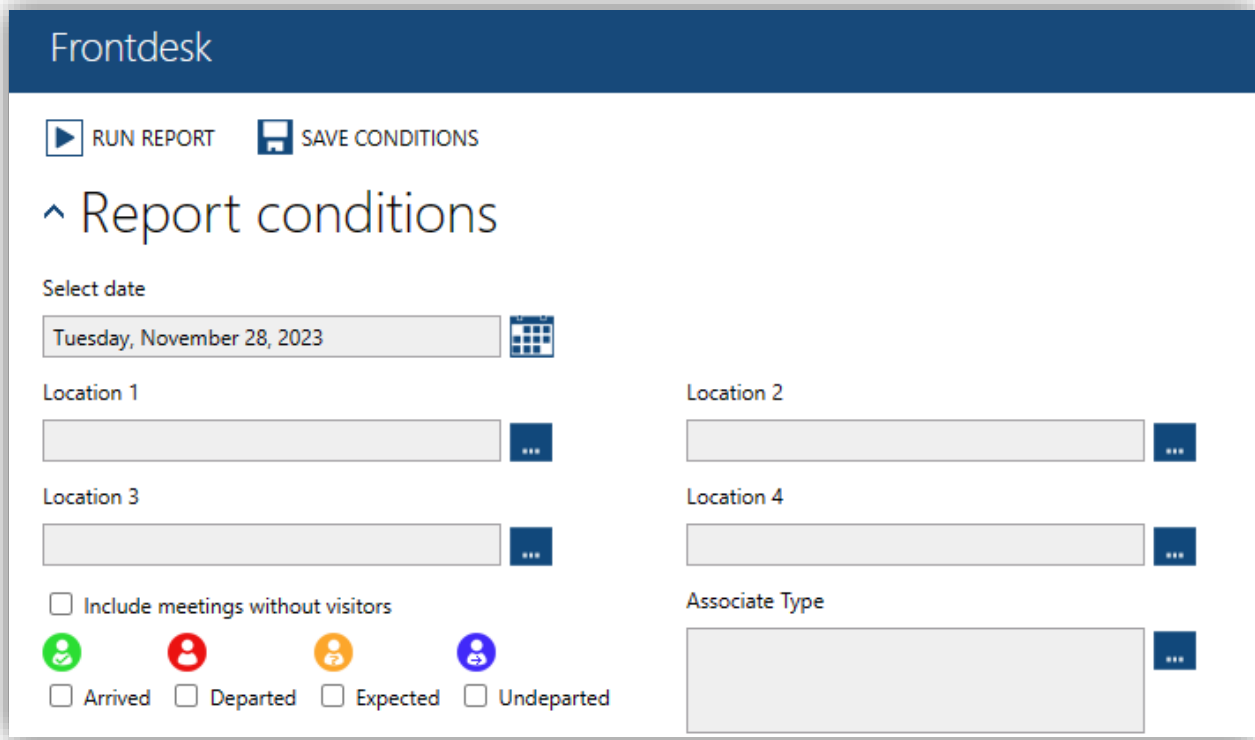

Figure 205. Front Desk - Report

You can select any date for which you want the summary as per Registered Attendees/Visitors. The report can only run for a single date.

Toolbar Buttons	Description
Save Conditions	Save conditions set this time for future use.
Run Report	Execute and displays the report for the selected date

Field	Description
Select Date	Calendar control by the help of which you can select a date on which you want to run the report
Location	Select the location to which the visitor is registered. The location must be defined in 'Location' tree under Location node.
Associate Type	The associate type of the visitor.

Checkboxes	Description
Include meetings without visitors	If you tick on this checkbox, the result will include both meetings with and without visitors.
Arrived/Departed/ Expected/Undeparted	Status of the visitor. If you tick on one status, the report will only export visitors with the selected state. You can select more than one status simultaneously.

After selecting the date, location(s), and other desired conditions, you will have to click the “Run Report” button at the toolbar, in the right pane, following which the report will be displayed at the same screen, as shown below:

Report result

1 of 1 Find | Next

Front Desk Report

Date: 03-10-2016
 Location:
 Sorting: Meeting start time - Then by meeting end time

Meeting time	Organizer and Guests	Phone No.	Meeting subject	Resource
03:00 AM - 03:30 AM	Administrator		Campaign Launch	Meeting Room 002
04:00 AM - 04:30 AM	Administrator		Project Meeting	Meeting Room 002
06:00 AM - 06:30 AM	Administrator		Project Meeting	Meeting Room 002
07:00 AM - 07:30 AM	Administrator John Smith Maria Brown		Project Meeting Add-On Company Add-On Company	Meeting Room 002
08:30 AM - 09:00 AM	Administrator Kenny Robert		Press Conference Add-On Company	Meeting Room 002

Figure 206. Front Desk - Report

Report Characteristics:

- The report can only be generated for a single day
- The report would be sorted automatically by Meeting Start Time
- The report is formatted to fit in a paper of A4 size
- The **Organizer** column shows the name of organizer in the first line and names of attendees in the sequent rows.
- The **Phone nr** column shows the phone number of organizer in the first line and those of attendees in the sequent rows.
- The **Meeting Subject** column shows the subject of appointment in the first line and Attendee's Companies in the sequent rows.

Cantina

The Cantina Report is designed to provide an overview of a reservation with respect to the Items in the Order. When you select the "Cantina Report" node in the tree view, the following screen of the report will appear:

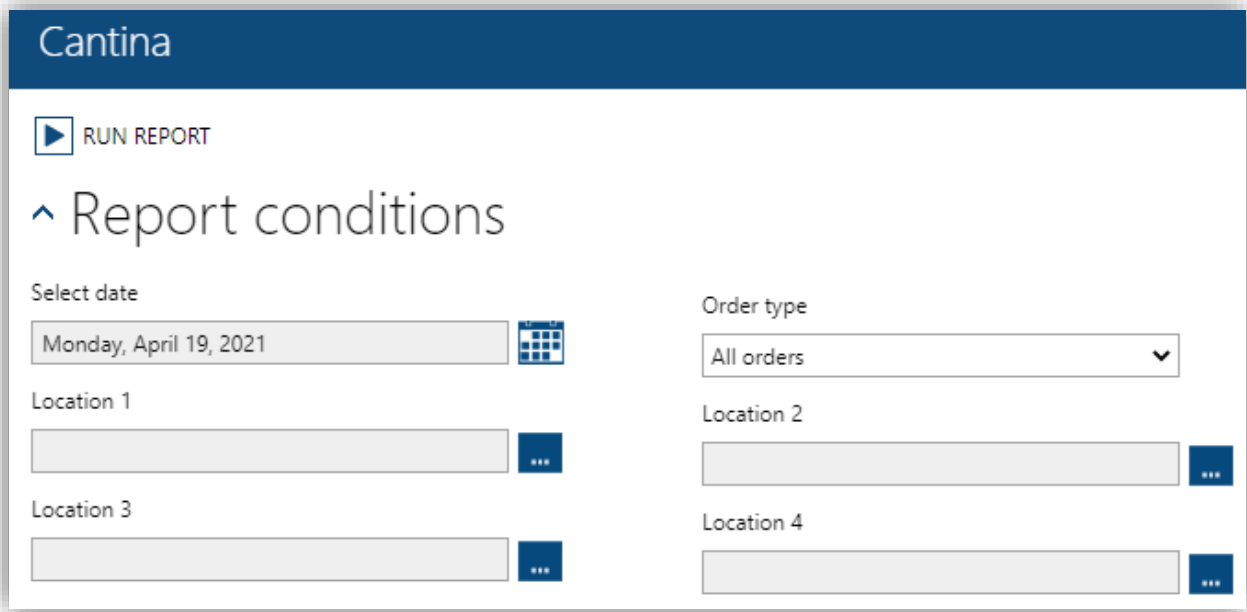

Figure 207. Cantina - report

You can select any date for which you want the summary as per ordered items. The report can only run for a single date.

Field	Description
Select Date	Calendar control by the help of which you can select a date on which you want to run the report
Order type	Select type of orders to be displayed

Toolbar Buttons	Description
Print	Print the selected page of the report
Run Report	Execute and displays the report for the selected date

After selecting the date, you will have to click the “**Run Report**” button at the toolbar, in the right pane, following which the report will be displayed at the same screen, as shown below:

Report result

1 of 1

Cantina Delivery Report

Date: 03-10-2016

Location: ■ Cancelled after deadline

Time	Items	Meeting Information	Order #	End Time
04:00	1 Cake	Meeting Room 002 Administrator	129	04:30
16:30	1 Cake	Meeting Room 002 Administrator	132	06:30

Deliveries: 2

Printed 30-09-2016 03.35 Page 1 of 1

Figure 208. Cantina - report

Report Characteristics:

- The report can only be generated for a single day.
- The report would be sorted automatically by Meeting Start Time.
- The report is formatted to fit in a paper of A4 size.
- The **Quantity** field shows the sum of all the items that have been ordered in different servings, but in the same reservation.
- If an item in an order which does not have consumed quantity specified, then when the consumed quantity appears, it will take the value from quantity as its default value.
- If the status of an Item is **Declined**, then it will not be included in the calculation.

If you want to have data regarding host of the meeting, please follow these steps:

1. In RC Manager, create a parameter with Key = Report.Cantina.HostName and Value = HostName
2. In RC Admin Interface, create a property with Number = HostName and Name = Host Name
3. Create a new Form and insert the "Host Name" property into the form
4. Assign the Form you created to a resource.

After that, when user books a reservation with the regarded resource, the order form will have a property named "Host Name" and user can input a name to it. This name will be considered when the report is run.

NOTES: If there is an item with edited name, that item will be shown on a different line other than the original one. E.g.:

Cantina Delivery Report



Date: 02/15/2023

Location:

Time	Items	Meeting Information	Order	End Time	Nr of attendees
04:00	2 Macaroncookies special with extra coconut	New York 101 Mark Olin	15272	04:30	
	1 Macaroncookies				

In this example, the item 'Macaroncookies special' is actually Macaroncookies item with edited name, therefore it is shown on a different line on the report.

Extra Services

The Extra Services Report is designed to give an overview of a reservation with respect to the Values of the Properties that have been set at the Order Form of a reservation. The contents of the report are controlled by an Advanced Parameter created at **RC Manager → General → Parameters** section, with the following specifications:

Parameter Name (Key): **ExtraServicesReport.PropertyList**

Parameter Value: Property ID (s) separated by commas (e.g., Property1, Property2)

For a specific reservation, if the value of a Property is set on the Order Form for that reservation and the ID of that Property is given in the value of the above-mentioned parameter, then when the Extra Service Report is run, the output will contain that Property's Caption along with its value as given on the Order Form.

NOTE: If the value of the above-mentioned Parameter is set to '-1', then the Output of the Report will contain the values of all those Properties, along with their captions, which have been set at their respective Order Forms against respective reservations.

When you click the Extra Service Report Node, the following screen will appear:

Figure 209. Extra Services - report

You can select any date for which you want the summary as per Extra Services Ordered. After selecting the date, you will have to click the “**Run Report**” button at the toolbar, in the right pane, following which the report will be displayed at the same screen, as shown below:

Report result

1 of 1

Extra Service Report

Date: 03-10-2016
Location:
Sorting: Meeting Start Time

Meeting time	Resource	Meeting Organizer	Order No.	Extra Services	Value
08:30 AM - 09:00 AM	Meeting Room 002	Administrator	137	Account Number	21545

Total Order: 1
Total Meeting: 1

Printed 30-09-2016 03.37 Page 1 of 1

Figure 210. Extra Services Output - report

If you click on the “**PRINT**” button at the toolbar, the Printer Interface will open so that you can have a print of the generated report.

Report Characteristics:

- The report can only be generated for a single day
- The report would be sorted automatically by Meeting Start Time
- The report is formatted to fit in a paper of A4 size

Constraints:

- If the Advanced Parameter “**ExtraServicesReport.PropertyList**” is not created or created with Blank value, then this report will not run.
- Property set at the Order Form of a reservation will NOT be listed in the Extra Service Report if its Property name is NOT mentioned in the Advanced Parameter’s Value.

Orders

The Orders report is designed to list all orders (items and/or properties) based on the roles and locations of the logged-in user who runs it.

When you select the “Orders” node in the tree view, the following screen of the report will appear:

Figure 211. Orders – Report

We will discuss each of the input fields as below:

1. Specify the interval by selecting dates in **“From date”** and **“To date”** input fields.
2. **“Location 1-4”** are non-editable lookup fields. This lookup will display all of the locations, so that you can select any of the locations.
3. Select display format for the report from the 3 options: **No page breaks**, **Page break after each order** and **Page break after each resource**.
4. Select type of order to be displayed in the report in **“Order type”**.
5. Check **“Include Sales Prices”** to include this column in the report result.
6. In order to have data for the column **“# of att.”** in the report result, please follow these steps:
 - a. In RC Manager, create a parameter with Key =NrOfAttendees and Value = Attendees
 - b. In RC Admin Interface, create a property with Number = Attendees and Name = Number of Attendees
 - c. Create a new Form and insert the “Number of Attendees” property into the form
 - d. Assign the Form you created to a resource.
 - e. After that, when you book a reservation with the regarded resource, the order form will have a property named “Number of Attendees” and you can input a number to it. This number will be considered when running the report.

After specifying all of the inputs, click on the **Run Report** button, at the toolbar in the right pane. The generated report will be displayed as following:

Report result

⏪ < 1 of 1 > ⏩
📄 🖨
🔍 Find | Next

Orders

Date: 03-10-2016
Location:
Roles: Host(Security Role), SDA

Order #	Start time	End time	Organizer	Subject	# of att.
Meeting Room 002					
129	04:00 AM	04:30 AM	Administrator	Project Meeting	
<div style="display: flex; justify-content: space-between; border-top: 1px solid #ccc; border-bottom: 1px solid #ccc; margin: 5px 0;"> 04:00 AM Serving 1 </div>					
1 Cake				8.00	
				8.00	
137	08:30 AM	09:00 AM	Administrator	Press Conference	
<div style="display: flex; justify-content: space-between; border-top: 1px solid #ccc; border-bottom: 1px solid #ccc; margin: 5px 0;"> Account Number 21545 </div>					
132	06:00 AM	06:30 AM	Administrator	Project Meeting	
<div style="display: flex; justify-content: space-between; border-top: 1px solid #ccc; border-bottom: 1px solid #ccc; margin: 5px 0;"> 06:00 AM Serving 1 </div>					
1 Cake				8.00	
				8.00	

Printed 30-09-2016 03.41
Page 1 of 1

Figure 212. Orders - report

Report Characteristics:

- The report can only be generated for a single day.
- The report will be sorted automatically by Resource Name, and then Order Number.
- The report is formatted to fit in a paper of A4 size.
- The **Quantity** field shows the sum of all the items that have been ordered in different servings, but in the same reservation.
- If no locations are selected, the user's locations must be used.
- If an item in an order which does not have consumed quantity specified, then when the consumed quantity appears, it will take the value from quantity as its default value.
- If the status of an Item is **Declined**, it will not be included in the calculation.

NOTES: If there is an item with edited name, sales price, or both, that particular item will be shown on a different line other than the original one. E.g.:

Orders



Date: 02/15/2023 - 02/15/2023

Location:

Roles: SysAdmin

Order	Start time	End time	Organizer	Subject	# of att.
15272	New York	101			
02/15/2023	04:00	04:30	Mark Olin	Team Meeting	
RC_Organizer_Company			ADC Company		
04:00	Serving 1				
	2	Macaroncookies special with extra coconut			-30.00
	1	Parfait			12.00
	1	Special Order A			150.00
	1	Macaroncookies			12.67
	1	Summer Set			150.00
04:00	Serving 2				
	2	Macaroncookies			-10.00
	1	Autumn Set			150.00
	2	Macaroncookies			25.34
	1	Winter Set			150.00
	1	Energy Drink			12.00

In this report, there are multiple 'Macaroncookies' items because many of them have their name, price, or both edited.

Tasks

Tasks report gives you an overview of the tasks, i.e., shared orders with respect to date and status. When you select the **Reports/Tasks** node in the tree view, the following screen of the report will appear:

Tasks

RUN REPORT

^ Report condition

From date:

To date:

Open Tasks All Tasks

^ Status filters

New Confirmed Declined Changed Deleted

Figure 213. Tasks report – Report condition

We will discuss each of the input fields as below:

1. You can specify the interval by selecting dates in “**From date**” and “**To date**” input fields.
2. Select to make a report on open tasks only or all tasks.
3. Select status to make the result more specific.

After specifying all of the inputs, click the **Run Report** button. The generated report will be displayed as following:

Report result

⏪ ⏴ of 1 ⏵ ⏩ 📁 ⌵ 🖨 Find | Next

Tasks

Add-On Products
Resource Central

Date: 19-10-2017 - 24-10-2017

Roles: Host(Security Role), Reception, Tickets, Booking Manager

Date	Meeting time	Order	Resources	Organizer	Subject	Status
19-10-2017	02:00 PM - 02:30 PM	1276	Meeting Room 201	John Smith 849156868888	Project Meeting	Deleted
			Video Conference/Telepresence Service Required	Yes		
	04:30 PM - 05:00 PM	1282	Conference Room 107	Administrator	Press Conference	Deleted
			Projekt Nummer/Project No Company	FA 187 Add-On Co. Ltd		
	11:00 AM - 11:30 AM	1273	Meeting Room 201	John Smith 849156868888	Board Meeting	Deleted
			Video Conference/Telepresence Service Required	Yes		

Figure 214. Report result

Report Characteristics:

- The report will be sorted automatically by Resource Name, and then Order Number.
- The report is formatted to fit in a paper of A4 size.
- If no status is selected, all tasks will be taken into calculation.

Tax Receipts

Tax Receipts report gives you an overview of all the tax receipts in the system. When you select the **Reports/Tax Receipts** node in the tree view, the following screen of the report will appear:

Figure 215. Tax Receipts report – Report condition

1. You can specify the interval by selecting dates in “From date” and “To date” input fields.
2. Select other conditions to make the result more specific.

After specifying all of the inputs, click the [Search] button. The generated report will be displayed as following:

Order ...	Delivery	Reservation At	Ends At	Subject	Organizer	Resource	Status
288	05:00	22-04-2021 05:00	22-04-202...	Press Conference 001	John Smith (john@psaod.onmicrosoft.c...	Meeting Roo...	Sent
279	17:30	22-04-2021 17:30	22-04-202...	Project Meeting 002	John Smith (john@psaod.onmicrosoft.c...	Meeting Roo...	Sent
256	19:00	22-04-2021 19:00	22-04-202...	Project Meeting 226	Samantha Jones (sam@psaod.onmicros...	Conference ...	Sent
260	21:30	22-04-2021 21:30	22-04-202...	Board Meeting	Samantha Jones (sam@psaod.onmicros...	Conference ...	Sent
299	22:30	22-04-2021 22:30	22-04-202...	Press Conference 022	Samantha Jones (sam@psaod.onmicros...	Conference ...	Sent

Figure 216. Report result

Report Characteristics:

- The report will be sorted automatically by Resource Name, and then Order Number
- The report is formatted to fit in a paper of A4 size

Week Planner

Week Planner report gives you an overview of the bookings of the resources, with respect to the Days and timeslots as per each day. When you select the “Week Planner Report” node in the tree view, the following screen of the report will appear:

Figure 217. Week Planner - report

NOTE: In order to run the Week Planner Report, you have to create the parameter **“WeekPlanner.TimePeriod”** at **RC Manager → General → Parameters**. The value of this parameter determines the consecutive timeslots to be shown in the Lookup windows of **“Time From”** and **“Time To”** input fields. The recommended values for this parameter are 15, 30, 45 or 60. However, you are allowed to enter any positive integer value. (If you enter the value of ZERO, then the default value of “30” will be taken).

We will discuss each of the input fields as below:

1. You can specify the interval by selecting dates in **“From date”** and **“To date”** input fields.
2. **“Location”** is a non-editable lookup field. This lookup will display all of the locations, so that you can select any of the locations. Report will as well show those resources that are in the selected node and its child nodes.
3. **“Resources”** is a lookup field. You can click the Lookup and select a resource. This lookup will display all of the resources in the location selected in **“Location”** field. If no specific location is selected, then all resources in the system will be taken into account.

<input type="checkbox"/>	▲ Resources	E-mail
<input type="checkbox"/>	Meeting Room 001	resource1@rc37.com
<input type="checkbox"/>	Meeting Room 002	resource2@rc37.com
<input type="checkbox"/>	Meeting Room 003	resource3@rc37.com
<input type="checkbox"/>	Meeting Room 004	resource4@rc37.com

Figure 218. Select Resource – Week Planner Report

4. **“Time From”** and **“Time To”** are lookup fields. You can only select from the populated values in the combo box. The value in these fields determines the start/end of the Time Slots in the Report. E.g., If Time From=08:00 and Time To=15:00, it means that the first timeslot in the Report will start from 08:00 and the last timeslot will end at 15:00, respectively.

Remember, the values in either of the dropdown lists will be displayed according to the value in the **WeekPlanner.TimePeriod** parameter. Suppose that the value in this parameter is “60”, then the values in either of these windows will be 01:00, 02:00, 03:00 and so on, as shown below:

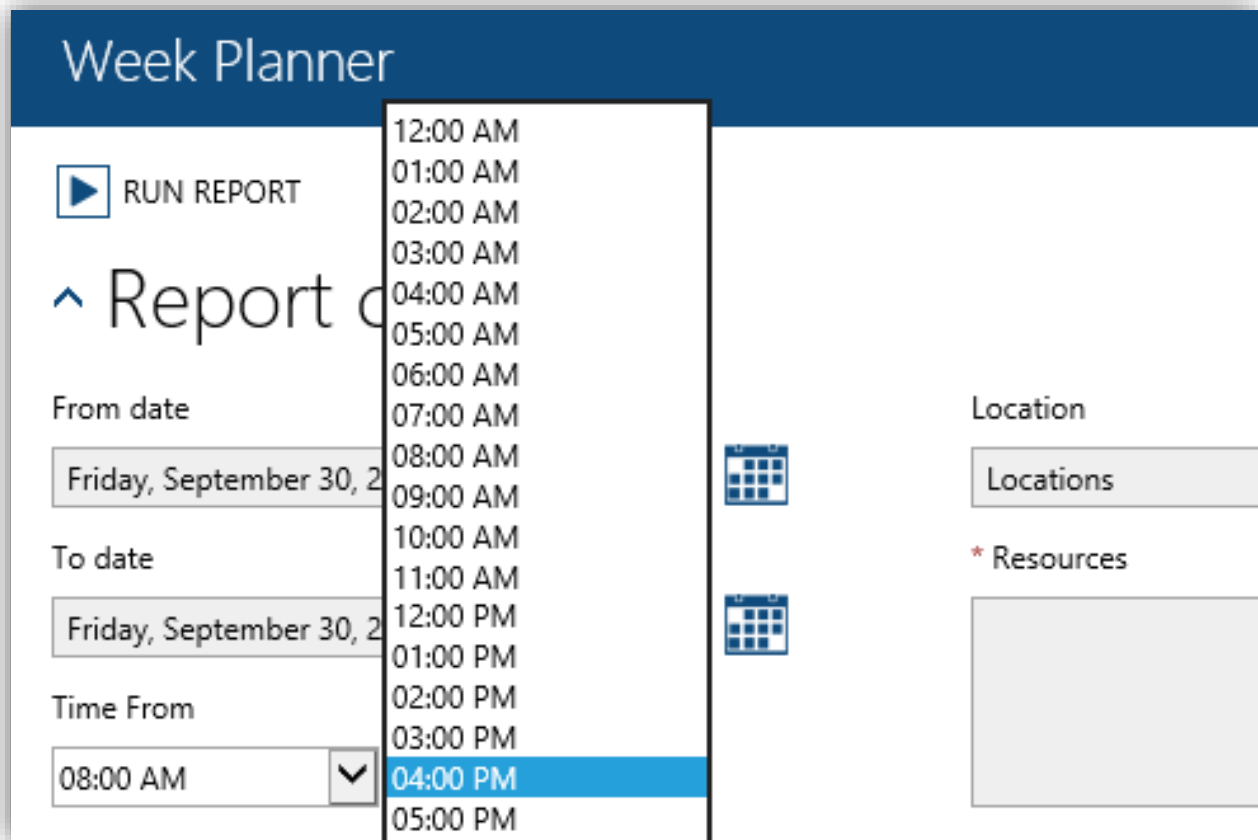

Figure 219. Select Time – Week Planner Report

NOTE: You can only run the report in the date range of less than or equal to 7 days.

5. **“Break Start”** is a non-editable lookup field. You can only select from the populated values in the Lookup field. Whatever time value you select, it will be taken as the Start Time for the Break to be shown in the Report.
6. **“Break Duration”** is a text field where you can enter any positive integer value. This would define the duration of the break interval (in minutes) between two consecutive rows in the report. Taking the above example, if Break Start=10:00 and Break Duration=30, then a Blank row with the label BREAK will be shown in the Report against the timeslot 10:00-10:30.
7. **“Slot Time”** is a combo box control, pre-populated with the values 15, 30, 45 & 60. This means that the single row in the report will be of this much duration. For example, suppose the value in Time Slot = 30. When we run the report, the rows will be displayed as 00:00-00:30, 00:30-01:00, 01:00-01:30 and so on.
8. **“Slot Difference”** is a text field where you can enter any positive integer value. This defines the interval (in minutes) between two consecutive rows in the report. Taking the above example, if Slot Difference = 10, then the rows will be displayed as 00:00-00:30, 00:40-01:10, 01:20-01:50 and so on.
9. **“Footer Text”** is a text field. You can enter any alpha numeric value in this field. This value will be displayed at the end of the generated report as the footer.
10. **“Text to Remove from Meeting’s Subject”** is a text box field. If you enter a text here, the report result will not include data of meetings that have that text in their subjects.

After specifying all of the inputs, click on the **Run Report** button. The generated report will be displayed as following:

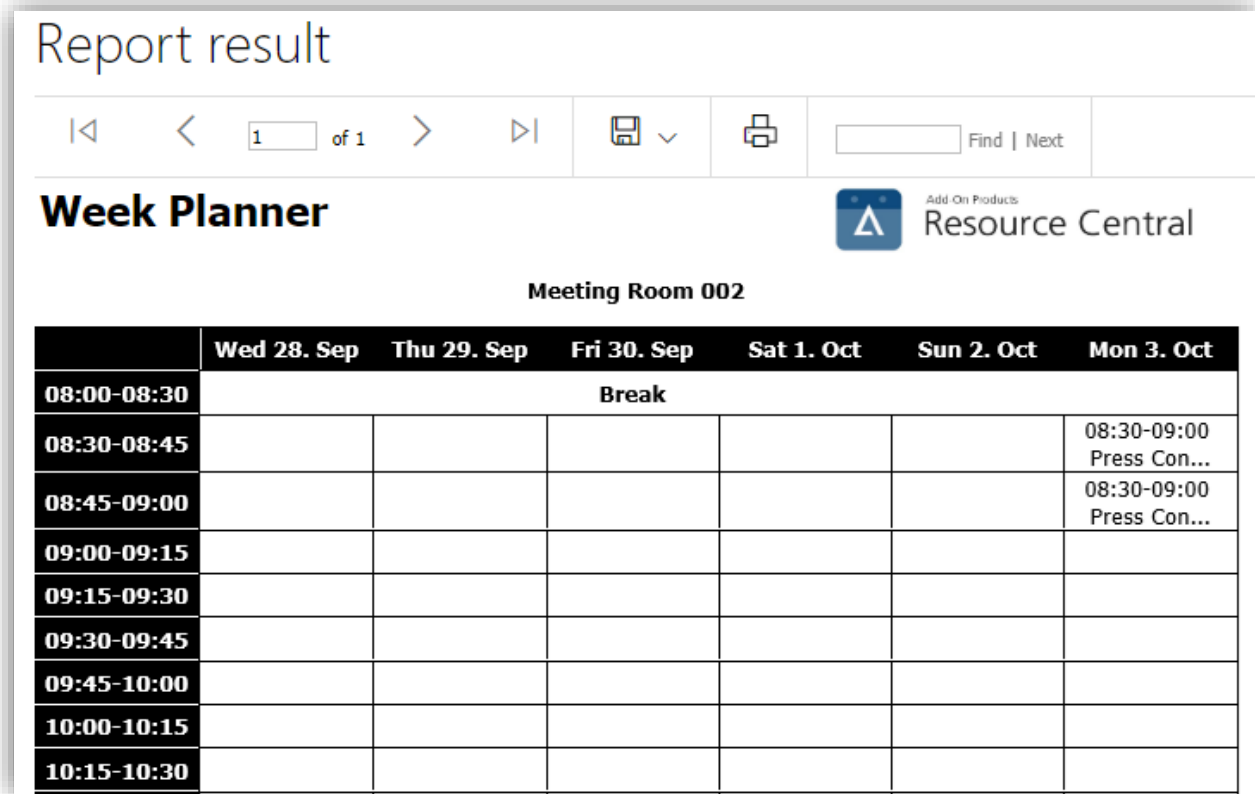

Figure 220. Week Planner Report Output

The subjects of all reservations will be displayed in all timeslots which contain Start time and/or End time of the reservation. That is, if the Week Planner Report is generated such that the duration of a reservation(s) is being split in more than one timeslot, then the reservation head of that reservation will be displayed in all of the corresponding timeslots, as shown in the figure above.

Excel

A number of “raw” data extracts is available in Excel format. The data is picked from the database against the columns that are shown in the report.

NOTE: User cannot select conditions for these Excel reports.

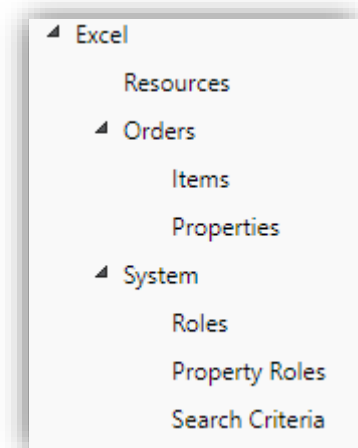

Figure 221. Excel

Upon selecting any of the nodes under the “Excel” node, you will be presented with the following dialog so that you may be able to **download or view the report in Excel format** in your browser:

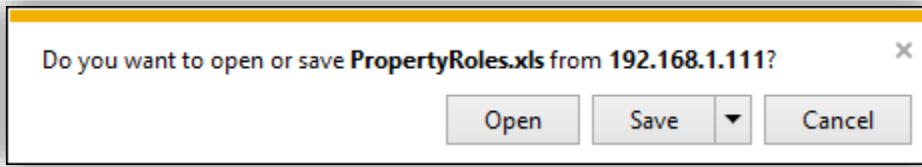

Figure 222. File Download dialog box

DISCLAIMER: All of the Excel based reports can only be run/viewed if the local system on which you are browsing the application has MS Excel installed, failing which none of these reports would run.

Each child node below is a report that can be opened or saved in Excel format.

- Under Excel there is a Resources report and a Reservations report.
- Under Orders there is an Items report and a Properties report.
- Under System there is a Roles report, Property Roles report and Search Criteria's report.

Excel – Resources

This report is designed to show all details related to all resources in the system.

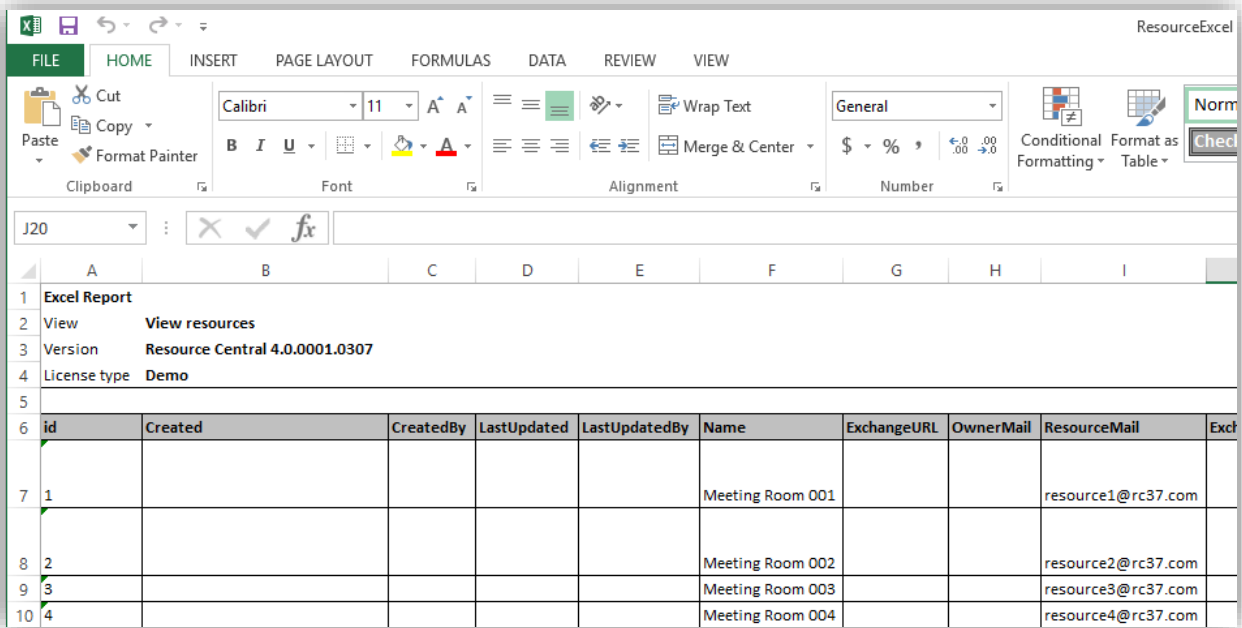

Figure 223. Resources Excel

Column name	Description	Location in DB to extract data
Id	ID of the resource in the DB	Resources table
Created	Time when the resource is created	Resources table
CreatedBy	Person who created the resource	Resources table
LastUpdated	Time when resource is last updated	Resources table
LastUpdatedBy	Person who lasts updated resource	Resources table
Name	Name of the resource	Resources table



ExchangeURL		Resources table
OwnerMail		Resources table
ResourceMail	Mail of the resource	Resources table
ExchangeServer		Resources table
Synchronize		Resources table
GroupName	Name of the group to which the resource belongs	Resources table
HTMLID	ID of used form in the resource	Resources table
MinimumHours	Minimum hour set in the resource	Resources table
LocationPath	Location ID of the resource	Resources table
DescriptionShort	Description entered in resource details	Resources table
ImageHref	Name of image attached to resource	Resources table
Capacity	Capacity of the resource	Resources table
Category1 to Category5	ID of categories to which the resource belongs. Default value is -1	Resources table
HTML	HTML source for Rich description of the resource	Resources table
CostPRMinute	A cost per minute entered in resource details	Resources table
CostInitial	An initial cost for the resource, entered in resource details	Resources table
UseServices	Number of services used with the resource	Resources table
UseGuestList	“Ask for Attendees in order form” field of the resource Yes = 1 No = 0	Resources table
FormName	Name of form attached to the resource	Name column of FormHTML table

Excel – Order

Excel – Order – Items

This report is designed to show all details of all items booked in orders.

OrderID	ItemID	Quantity	ItemName	SalesPrice	CostPrice	SortOrder	Caption
1		1	2 Coffee	5	7		Coffee
1		5	2 Tea	8	10		Tea
2		1	3 Coffee	5	7		Coffee
2		5	3 Tea	8	10		Tea
4		1	0 Coffee	5	7		Coffee
4		3	1 Cake	8	12		Cake

Figure 224. OrderItems Excel

Column name	Description	Location in DB to extract data
OrderID	ID of the order	OrderLines table
ItemID	ID of the item	OrderLines table
Quantity	Quantity of the item in a specific order	OrderLines table
ItemName	Name of the item	OrderLines table
SalesPrice	Value of "Sales Price" field in Item's details	Items table
CostPrice	Value of "Cost Price" field in Item's details	Items table
SortOrder	Value of "Sort Order" field in Item's details	Items table
Caption	Value of "Name" field in Item's details	Items table

Excel – Order – Properties

This report is designed to show all details of all properties booked in orders.

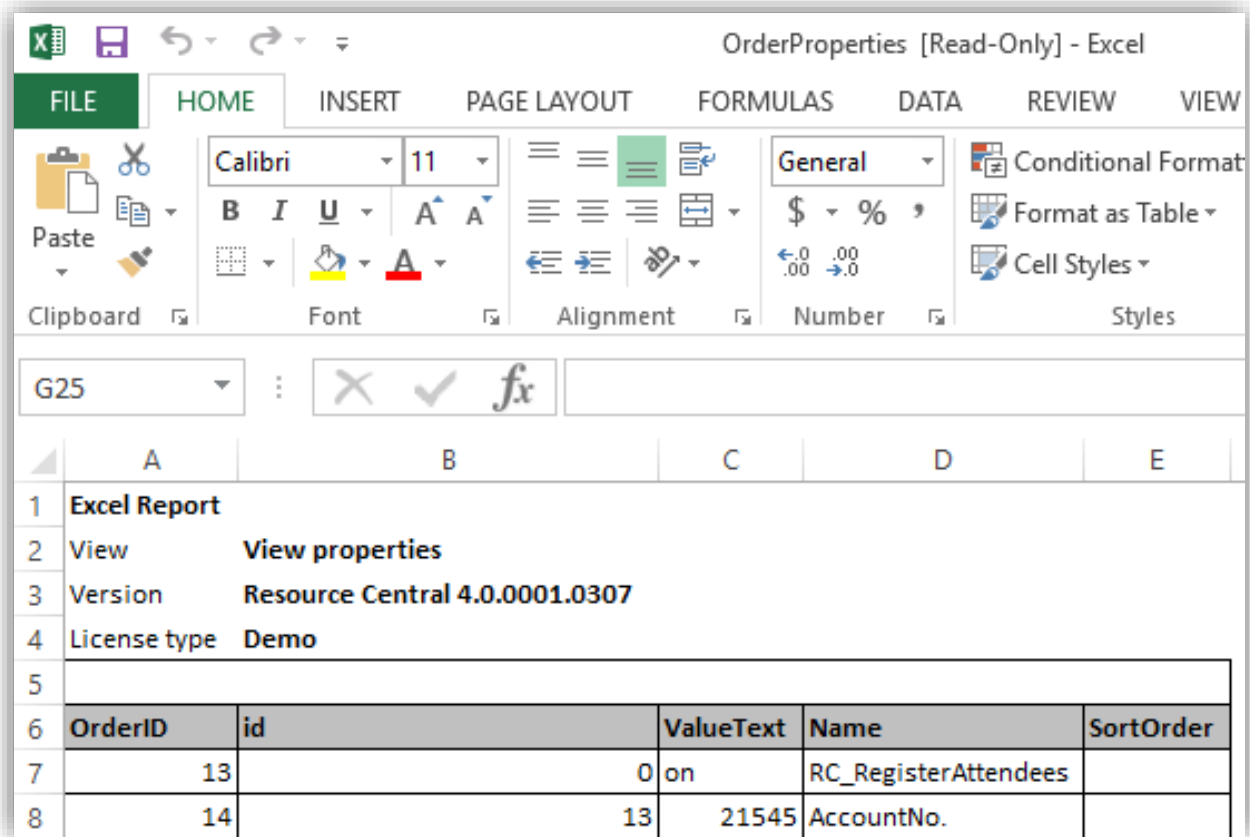

Figure 225. OrderProperties Excel

Column name	Description	Location in DB to extract data
OrderID	ID of the order	Orders table
id	ID of the property	PropertyTypes table
ValueText	Value entered into the property in order form	PropertyValues table
Name	Name of the property	PropertyTypes table
SortOrder	Value of "Sort Order" field in property's details	PropertyTypes table

Excel – System

Excel – System – Roles

This report is designed to show all details of those roles which are assigned to persons.

ID	PersonID	RoleID	RoleName	PersonName	PersonFriendlyName
1		1	Host(Security Role)	HOST	Host (Security)
2		2	1 Host(Security Role)	System	Resource Central Manager
3		1	2 SDA	HOST	Host (Security)
5		3	2 SDA	john	John Smith

Figure 226. PersonRoles Excel

Column name	Description	Location in DB to extract data
ID		Person2Roles table
PersonID	ID of the person	Person2Roles table
RoleID	ID of the role	Person2Roles table
RoleName	Name of the role	Roles table
PersonName	Name of the person	Persons table
PersonFriendlyName	Display Name in Person's details	Persons table
PersonDescriptionShort	Description in Person's details	Persons table
isSecurity	Value selected for "Role is a security role" field in Role details (Yes = 1, No = 0)	Roles table
canEdit	Value selected for "Role can edit orders" field in Role details (Yes = 1, No = 0)	Roles table
suppressMail	Value selected for "Suppress mails" field in Role details (Yes = 1, No = 0)	Roles table

Excel – System – Property Roles

This report is designed to show details of properties, each of which is assigned with at least a role.

ID	PropertyID	RoleID	PropertyName	RoleName	Caption
1		0	RC_RegisterAttendees	Host(Security Role)	Check this box if attendees
2		0	RC_RegisterAttendees	SDA	Check this box if attendees
3		12	VR_ArrivalDate	SDA	ArrivalDate
4		8	VR_Barcode	SDA	Barcode
5		11	VR_Category	SDA	Category
6		10	VR_Comments	SDA	Comments
7		3	VR_Company	SDA	Company

Figure 227. PropertyRoles Excel

Column name	Description	Location in DB to extract data
ID		Property2Roles table
PropertyID	ID of the property	Property2Roles table
RoleID	ID of the role	Property2Roles table
PropertyName	Name of the property	PropertyTypes
RoleName	Name of the role	Roles table
Caption	Value enters to “Text” field in property’s details	PropertyTypes
PropertyDescriptionShort	Value enters to “Description” field in property’s details	PropertyTypes
RolesDescriptionShort	Value enters to “Description” field in role’s details	Roles

Excel – System – Search Criteria

This report is designed to show an overview of all filters in the system.

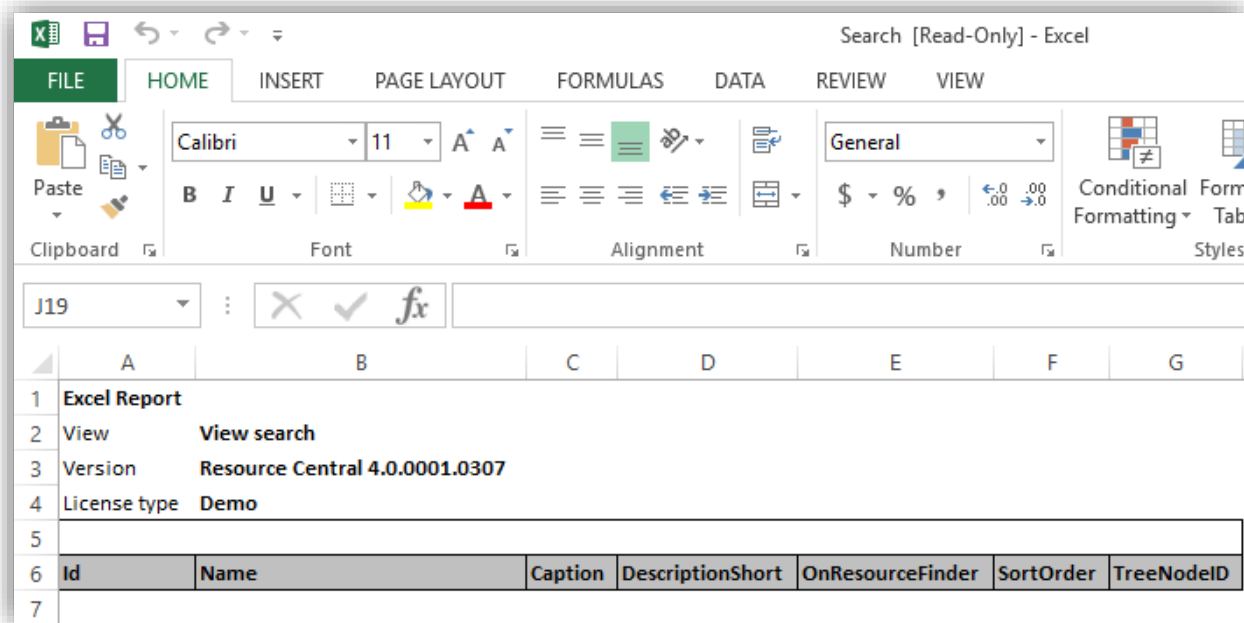

Figure 228. Search Criteria Excel

Column name	Description	Location in DB to extract data
Id	ID of the filter	Property2Roles table
Name	Name of the filter	Search table
Caption	Value entered in “Caption” field of the filter’s details	Search table
DescriptionShort	Value entered in “Description” field of the filter’s details	Search table
OnResourceFinder	Value entered in “Frontpage” field of the filter’s details (Yes = 1; No = 0)	Search table
SortOrder	Value of “Sort order” field in filter’s details	Search table
TreeNodeID	ID of the filter’s “Tree position”	Search table

SQL

This interface is provided for advanced level data management. Through this view, you can execute SQL statements directly on Database and view the result under the form of a table.

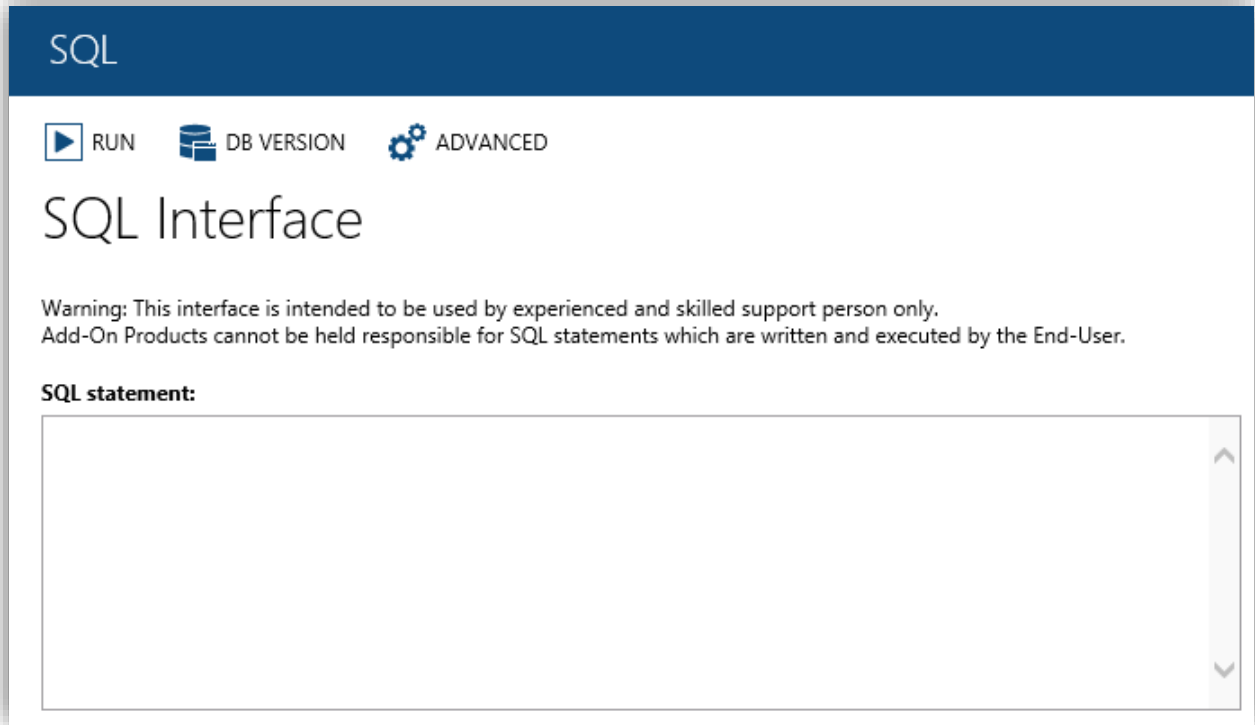

Figure 229. Database – SQL Design

Clicking [DB version] button shows the DB version in use:

ServerName	InstanceNa...	DataBaseN...	DataBaseUser	RC URL	RC DB Versi...	SQLVersion	SQLBuild	Broker Status
RC1	NULL	RC	sa	https://rc1...	4.3.0007.0...	Microsoft ...	15.0.2000....	true
RC URL		Endpoint						
ResourceServiceURL		https://rc1.add-on-company.com/ResourceCentralGateway/resource-api						
ApplicationURL		https://rc1.add-on-company.com/ResourceCentral						
ReservationServiceURL		https://rc1.add-on-company.com/ResourceCentralGateway/reservation-api						
LocalReservationServiceURL		http://localhost/ResourceCentralGateway/reservation-api						
NotificationServiceURL		https://rc1.add-on-company.com/ResourceCentralGateway/notification-api						
VisitorServiceURL		https://rc1.add-on-company.com/ResourceCentralGateway/visitor-api						
OrderServiceURL		https://rc1.add-on-company.com/ResourceCentralGateway/order-api						

Figure 230. Show DB information

The following screen is the advanced mode of **SQL** which is accessed by clicking [**Advance**] button. Through this interface you can download the result of **SQL** queries on your own machine. You can also execute the update query.

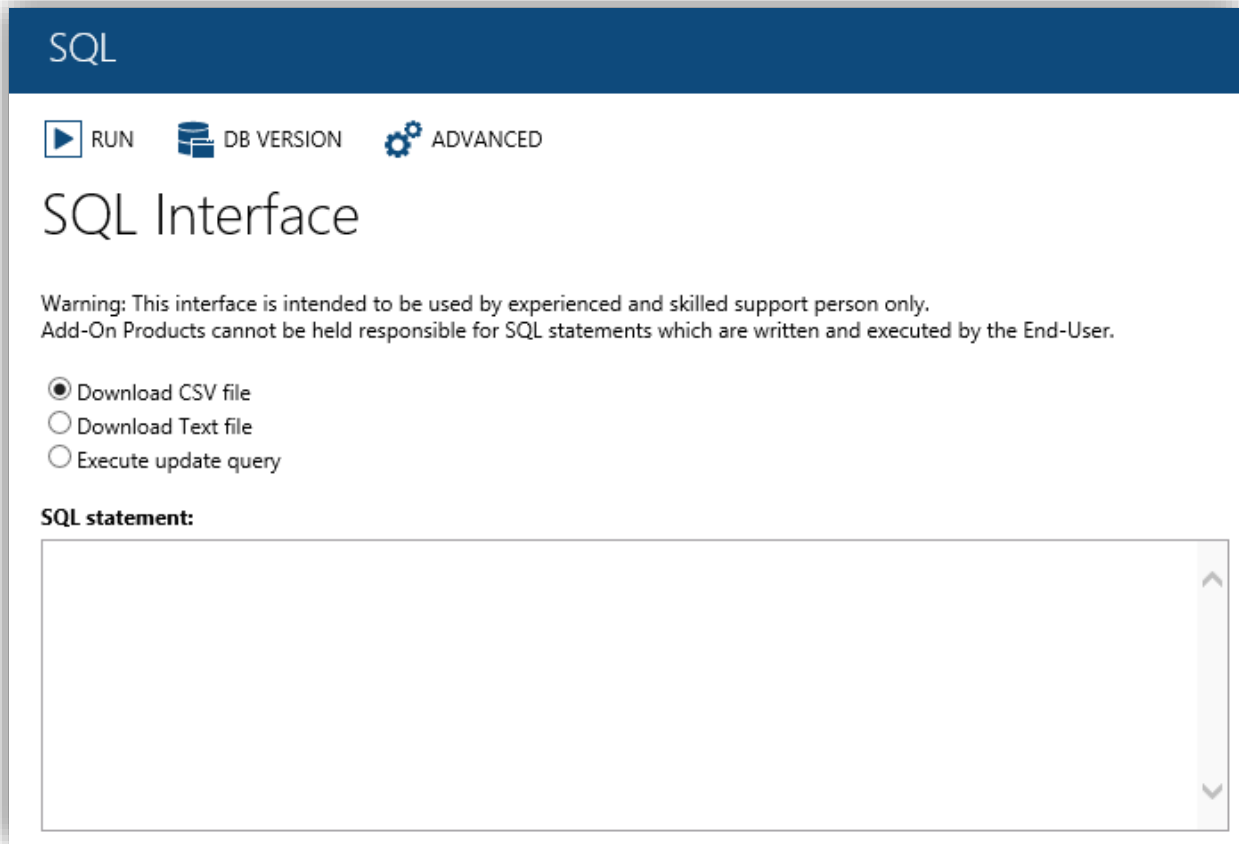

Figure 231. Advance mode of SQL

NOTE: It is strongly recommended that this interface must be used by experienced support personnel, who should be proficient in writing/using SQL statements and well aware of the Resource Central Database design. Incorrect use of this interface may halt the Resource Central System or may permanently destroy the data.

Toolbar button	Description
Run	Click on Run to execute the query.
DB version	Show DB version in use
Advance	Advanced mode of SQL

Custom Reports

The content of each custom report is based on customer's requirements. Please refer to the specific custom report guide for detailed instruction on how to install and run the report.

NOTE: For smooth operation in Cloudflare, you need to compress the aspx file into a ZIP file before uploading a custom report.

Designer

In the Designer section, you are able to **design, configure** and **monitor** the system. Here you can customize the application as you desire.

NOTE: In this section, there is a sub-section named “Kiosk Screens” for visitor registration. For more details about this feature, please refer to *Kiosk Administrator Guide*.

The **DESIGNER** section consists of the following areas:

- [Resources](#)
- [Virtual Resources](#)
- [Forms](#)
- [Nutrition](#)
- [Visitors](#)
- [Properties](#)
- [Lookup Values](#)
- [Images](#)
- [Filters](#)
- [Badges](#)
- [Kiosk Screens](#)
- [Orders](#)
- [Meetings](#)
- [Resource Type](#)
- [Help](#)
- [Tax Receipt](#)

Resources

‘Resource’ screen contains the definition of all the resources (**MS Exchange/Outlook calendars**) that are to be used in Resource Central.

Resources shown here are used in making reservations, ordering of different services for a respective meeting. Different associations with the resource are also defined here. For instance, Items relating to a resource, Person/Role relations with the resource.

Name	Group Name	Resource email	Location	License Type
Conference Room 1215	Conference Rooms	ConferenceRoom1215@rc.com	Locations	Standard
Conference Room 1216	Conference Rooms	ConferenceRoom1216@rc.com	Locations	Standard
Meeting Room 2010	Meeting Rooms	MeetingRoom2010@rc.com	Locations	Standard
Meeting Room 2011	Meeting Rooms	MeetingRoom2011@rc.com	Locations	Standard
Meeting Room 3011	Meeting Rooms	MeetingRoom3011@rc.com	Locations	Standard
Meeting Room 3015	Meeting Rooms	MeetingRoom3015@rc.com	Locations	Standard

Figure 232. List of Resources

NOTE: **Designer → Resources** node has been made role-based against the Location(s) of the logged in person, i.e., you can only view Resource(s) that belong to your Absolute Location(s) or Children Location(s). Also, you can only create/update Resource(s) at your Location(s). If you try to create/update a Resource to such a location that is not the Absolute Location or the Child of the logged in Person, then the system does not allow you to do so and a proper warning message will be displayed, as shown below:

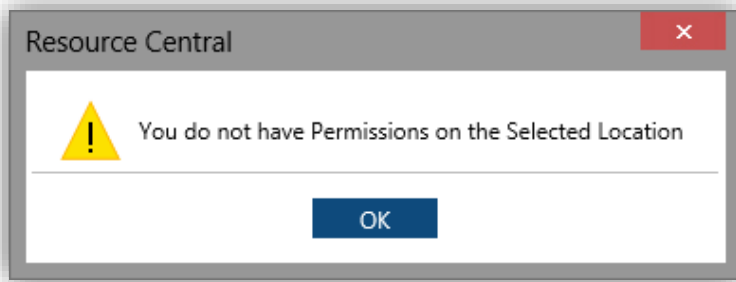

Figure 233. Permission denied message

Toolbar Buttons	Description
New	Create a new Resource
Delete	Delete a selected Resource
Bulk Update	Update multiple resources. Refer to this section for more details
Import	Import multiple resources. Refer to this section for more details

Clicking one of the resources will show details about it.

Resource Details

From the **resource detail view**, you can **edit** and **save** the record, enter description of the resources in **HTML** format using the built-in editor.

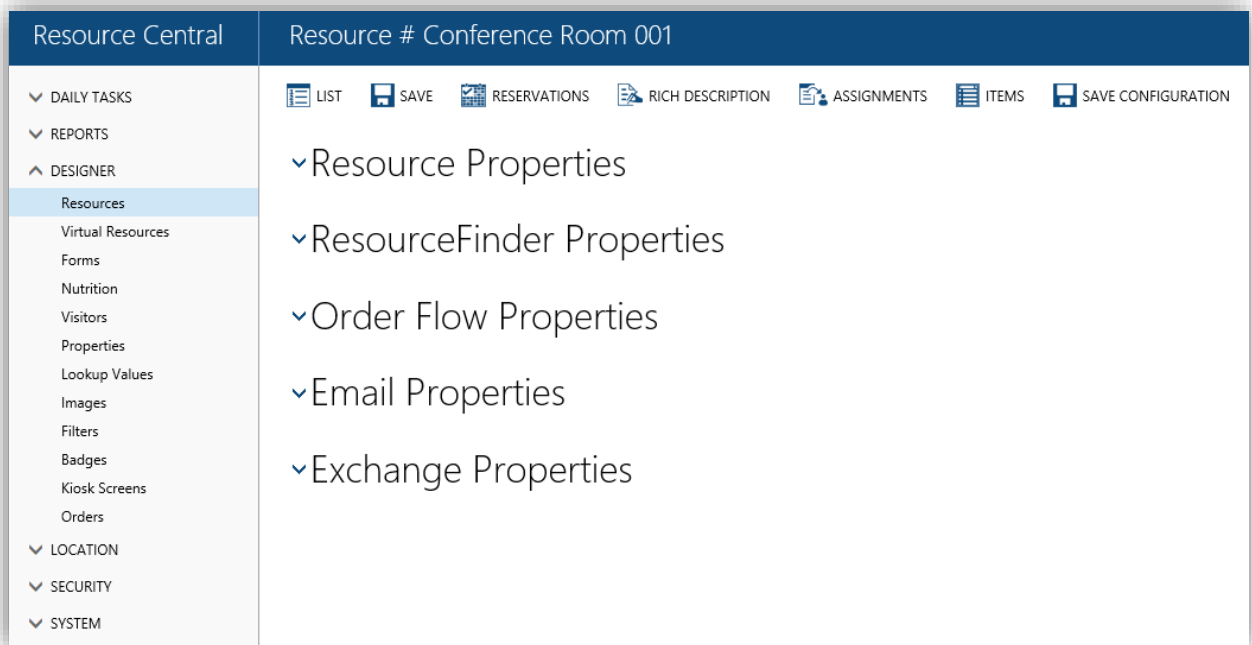

Figure 234. Resource Details

You can **view** which person/roles are assigned to the resource. You can also **edit** the list of items related to the resource.

Field	Description
Resource Properties	
<div style="border: 1px solid #ccc; padding: 10px;"> <h3>^ Resource Properties</h3> <p>Resource Data Synch Time 2024/05/08 10:30 ✔</p> <p>* Resource Mail RC1_008@rcaod.onmicrosoft.com ...</p> <p>* Name CSG HotDesk 6</p> <p>Description <div style="border: 1px solid #ccc; height: 40px; width: 100%;"></div> 🔒</p> <p>License Type Standard ▼</p> <p>* Group Name HotDesks ...</p> <p>* Location Locations\Belgium\Bruxelles ...</p> <p>Time Zone ▼</p> <p>Categories Cars ...</p> <p>Image Car_Passat_limousine.jpg ...</p> <p>Resource location image <div style="border: 1px solid #ccc; height: 20px; width: 100%;"></div> ...</p> <p>Resource location description <div style="border: 1px solid #ccc; height: 40px; width: 100%;"></div></p> <p>Sign Name <div style="border: 1px solid #ccc; height: 20px; width: 100%;"></div></p> <p>* Send Email <input checked="" type="radio"/> Yes <input type="radio"/> No</p> <p>Include in utilization calculation <input checked="" type="radio"/> Yes <input type="radio"/> No</p> </div>	

There are 2 symbols adjacent to some fields in this section:

Locked 🔒: Data of this field is synchronized from Exchange when the synchronization sets off.

Unlocked 🔓: Data of this field is NOT synchronized from Exchange when the synchronization sets off.

To establish which field in Exchange can be synchronized to a field in a resource's details, please refer to [Resource Data Synch](#) section.

Resource Data Synch Time	The last time a successful synchronization is complete.
*Resource Mail	Search & select the email address (SMTP address) of the resource (Mandatory field). Based on the clue typed in this field, a list of relevant mailboxes (registered by RealTime Service Manager) is displayed. If there are no relevant mailboxes, the following message is displayed:

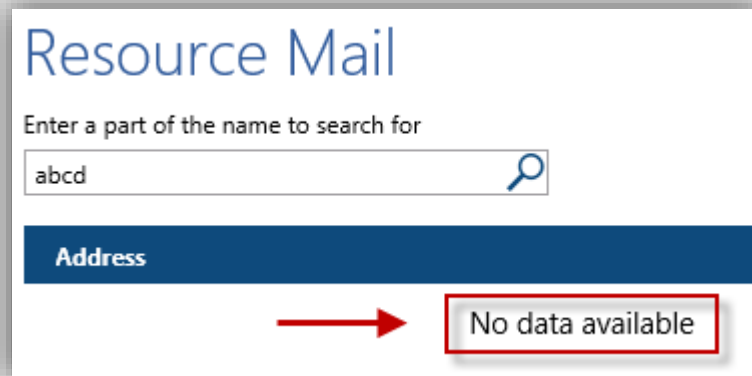

*Name	A friendly name for the resource (Mandatory field)
Description	Description of the resource
*License Type	<p>The value of this field categorizes the resource to be either Light or Standard or Pooled (Mandatory field).</p> <p>Standard A standard resource supports ordering of catering and extra services.</p> <p>Light A light resource is for resources that do not require any services. The 'Order Flow' section will be deactivated.</p> <p>Pooled Resource Pooled Resource licenses are uses as part of a single RC resource, where the configured capacity determines how many licenses are used. Typically used for a pool of desks where the organizer can book one or more of the desks from the pool - but not a specific desk. Parking places can also be Pooled Resources.</p> <p><u>Important information:</u> See below section: "Pooled Resources - Configuration in Exchange" on how to set configure Pooled Resources.</p>
*Group Name	<p>Group Name can be used for categorizing the resources. (Mandatory field). It is an editable lookup field, where you can select any of the already created groups or you can write a new one.</p> <p>Whenever you are viewing the "Orders", "Reservations" or "Overview" in the Daily Tasks section, you have the option of filtering the data by group. The group is also used in the Report section, allowing you to segment reports based on group intervals.</p>
*Location	<p>Select the location of resource. (Mandatory field) The location must be defined in 'Location' tree under Location node.</p>
Time Zone	Time Zone of the resource to convert the reservation & serving times accordingly.
Categories	Select categories of resource. The categories must be defined in ' Location ' tree under Categories node.
Image	Select/de-select an image of the resource. This image will be displayed in ResourceFinder and the Order form.
Resource location image	Refer to Logistics and delivery management section in <i>Resource Central Provider Guide</i> for more knowledge on how to use these features.

Resource location description	
Sign Name	This is name of the resource which will be exported in XML file of Signage
Send Email	Select YES if you want to allow emails to be sent for a resource or not. If you select NO, then the Organizer and/or the Service Provider(s) would not get any email(s) regarding the changes of the reservation of this resource. NOTE: This option does not apply for emails on Shared Orders. If License Type is Light, this option is also unavailable.
Include in utilization calculation	Select Yes to include this resource in the utilization and external percentage calculation defined for this resource's location. When set on a standard or light resource, the capacity is automatically set to one, as this is a requirement for the utilization calculation on standard or light resources meant for e.g., group of individual hot desks. NOTE: In the case when you are changing an existing room with capacity higher than one to be included in the utilization calculation, Resource Central will automatically set the capacity to one at [Save] and delete all future reservations on this resource where the bookings exceed a capacity of one.

ResourceFinder Properties

Capacity	A number indicating the capacity of this resource. When using Pooled Resources license type the capacity is what determines how many of the Pooled resource licenses the configured Resource consists of.
-----------------	--

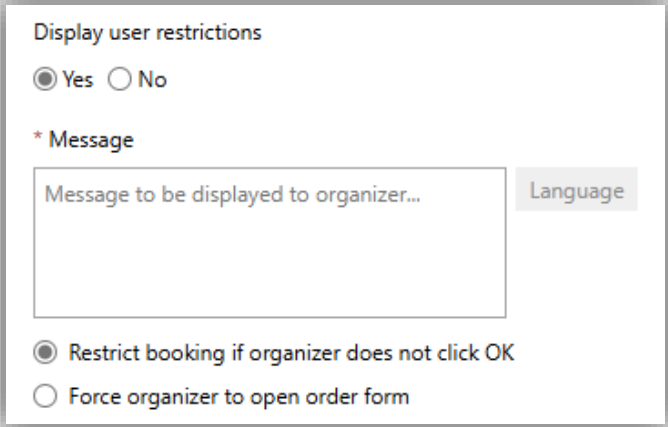
	Your Pooled Resource licenses can be spread across several Resources and a counter above the Resource List informs you how many of the licenses that are in use.
Resource Type	Select a type for this resource. These resource types can be configured in Designers/Resource Type . For more information and configuration options please see this section .
Make Resource Invisible	If you check this checkbox for a resource, that resource will not be displayed at the ResourceFinder screen.
Display user restrictions	<p>If you check this option for a resource, a message will be displayed in ResourceFinder when this resource is selected. This message can be edited in all the different languages in RC.</p>  <p>Restrict booking if organizer does not click OK: Message defined here will be displayed when organizer selects the resource in ResourceFinder</p> <p>Force organizer to open order form: You can check “Normal Order Form” or “Shared Order Form” or both to indicate what order forms organizer must open, otherwise a warning message is displayed.</p>
Sort Order	Sort order can hold any alphanumeric values and is used for sorting of the resources over the ResourceFinder window
Cost initial	An initial cost for the resource, used for exports to invoice system
Cost per minute	A cost per minute for use of the resource, used for exports to invoice system
Open Start time	<p>This will determine the Start time for the Opening Hours of the Resource. By Open, it means that the respective resource would be displayed such that it is BOOKABLE in the specified time interval. The Default value for this is 00:00.</p> <p>And if you try to book the resource in the time out of the Open Time Interval specified, you will not be allowed to do so, and a proper warning message will be displayed.</p> <p>If some value is specified in this field (other than the Default), then its Impact can be seen at:</p> <ul style="list-style-type: none"> • ResourceFinder Timeline grid • RC Admin → Daily Tasks → Overview <p>The time outside the Opening Hours Interval will be considered as Closed Hours for this resource.</p>

	<p>If you want to avoid users booking the resources directly from exchange during closing hours, setup Exchange Open start time and Open end time on the resource which can be synchronized into Resource Central with Resource Data Synch.</p> <p>NOTE: This field works based on the operation of the field Time Zone. If Time Zone is locked (🔒), this field is accordingly locked.</p>
<p>Open End time</p>	<p>This will determine the End time for the Opening Hours of the Resource. The Default value for this is 00:00.</p> <p>If you want to avoid users booking the resources directly from exchange during closing hours, set up Exchange Open Start Time and Open End Time on the resource which can be synchronized into Resource Central with Resource Data Synch.</p> <p>NOTE: This field works based on the operation of the field Time Zone. If Time Zone is locked (🔒), this field is accordingly locked.</p>
<p>Pre and post buffer time</p>	<p>The value in this field will determine the length of the time (in minutes), to be shown as BOOKED in the ResourceFinder only, before and after the actual reservation occupation of the resource.</p> <p>For example, if you set the Pre and post buffer time = 30 for a resource and a reservation has been placed over the same resource from 08:00am to 08:30am, then at the ResourceFinder, this reservation will be displayed as BOOKED for the timeslot 07:30am to 09:00am (that is, half an hour before and after the actual reservation time)</p> <ul style="list-style-type: none"> This value ranges from 0 to 180 minutes. If you enter a value that is greater than 180, a message will appear as below: <div data-bbox="592 1279 1350 1491" data-label="Image"> </div> <ul style="list-style-type: none"> Default value for this field is 0 Impact of the value of this field will only be displayed in the ResourceFinder.
<p>Notification of Closing Date</p>	<p>The date to send email to organizers notifying beforehand that resources are going to be closed.</p> <p>NOTE: Along with 'Closing Date' and 'Opening Date' fields below, these fields are used for 'Close Resource' feature (refer to this section for more details).</p>
<p>Closing Date</p>	<p>The start date when resources close for bookings (unavailable).</p>
<p>Opening Date</p>	<p>The date when resources open again for bookings (available again).</p>



Close permanently If you check on this option, the resource will be closed permanently from the Closing Date.

Order Flow Properties (This section will only be available if "Light Resource = No")

Order Flow Properties

Display Reservation
 Yes No

Display Order
 Yes No

Display Visitors
 Yes No

Display Properties
 Yes No

Form
 CSG Form

Shared order form

Tentative order
 Yes No

*** Hide order form on tentative appointments**
 Yes No

Ask for visitors in order form
 Yes No

Classic format
 Yes No Display groups

Item Selection
 Quantity Checkbox Min. no. of persons.

Deadline for catering

Workdays before: Time:

*** Exceeded deadline message**

The Deadline for Catering is exceeded. Language

Deadline for Extra Services

Workdays before: Time:

*** Exceeded deadline message**

The Deadline for Services is exceeded. Language

Maximum number of deliveries

Display Reservation	<p>'Yes': Reservation section is available in Order Form of this resource.</p> <p>'No': Reservation section is unavailable in Order Form of this resource.</p>
Display Order	<p>'Yes': Order Details section is available in Order Form of this resource.</p> <p>'No': Order Details section is unavailable in Order Form of this resource.</p> <p>The impact of either of the values selected will also be displayed in the corresponding emails.</p>
Display Visitors	<p>'Yes': Visitors section is available in Order Form of this resource.</p> <p>'No': Visitors section is unavailable in Order Form of this resource.</p> <p>The impact of either of the values selected will also be displayed in the corresponding emails.</p>
Display Properties	<p>'Yes': Properties section is available in Order Form of this resource.</p>

	<p>'No': Properties section is unavailable in Order Form of this resource.</p> <p>The impact of either of the values selected will also be displayed in the corresponding emails.</p>
Form	<p>Select one of the defined forms. This form will be displayed to the organizer while placing the order. This field and Shared Order Form field is mutually exclusive.</p>
Shared Order Form	<p>Select one of the defined SOF. This form will be displayed to the organizer if he selects various resource having the same SOF. This field and Form field is mutually exclusive.</p>
Tentative Order	<p>Usage of Tentative order mark to control the order flow when having resources with delegate on:</p> <ul style="list-style-type: none"> • If you select Yes → The order is created at once and is visible to the service provider. • If you select No → One-step order is allowed but the order must wait for acceptance of the reservation from the delegated person before it is created. Changes to approved reservations will update the order at once. <p>This option works in correlation with the Delegate option.</p> <p>Using the delegate option (yes/no) will control if one-step ordering is allowed.</p> <p>NOTE: To use tentative order flow on Shared Orders (Tasks) you must set the new parameter 'Tentative.SOFFlow' to 1. Refer to RC Parameter Guide for more details.</p>
Hide order form on tentative appointments	<p>This feature enables whether the order form is visible to the organizer before or after the resource reservation is accepted by Exchange (either by auto accept or delegate accept).</p> <p>Yes: You cannot use the order form in ResourceFinder on new reservations.</p> <p>No: You can use the order form in ResourceFinder on new reservations.</p>
Ask for visitors in order form	<p>You can select either "Yes" or "No". If Yes is selected, then the organizer will be given an option to enter the information of meeting visitors. That information will be used in Visitors section.</p>
Classic format	<p>The value of this field will determine the mechanism by which the Servings will be ordered over the order form of this respective resource. By default, the value is 'Yes'.</p> <p>If the value of this field is 'Yes', then the servings will be ordered in the normal way as before.</p> <p>If the value of this field is 'No', then each serving will be displayed in the form of drop-down boxes as per the groups which the associated item(s) belong to.</p> <p>Check 'Display groups' if you want the items in order form is displayed as groups.</p>
Item Selection	<p>Select how items will be displayed for booking:</p> <ul style="list-style-type: none"> • Quantity: There is a field to enter the required quantity per item in order form. • Checkbox: The ordering in order form will be made by checking the required items. In this case you must enter Minimum Quantity (Min. qty.) that must be ordered (this is only available when 'Checkbox' is selected).
Deadline for Catering	<p>When the user selects this checkbox, the deadline for booking items can be selected in time range underneath (Workdays before and Time).</p>

	<p>E.g.</p> <ul style="list-style-type: none"> - Meeting time is 25/04/2021. - Workdays before = 2 - Time = 14:00 <p>This means that the deadline for catering is 14:00 (23/04/2021).</p>
Deadline for Services	<p>When the user selects this checkbox, the deadline for booking properties can be selected in time range underneath (Workdays before and Time).</p> <p>E.g.</p> <ul style="list-style-type: none"> - Meeting time is 25/04/2021. - Workdays before = 2 - Time = 14:00 <p>This means that the deadline for services is 14:00 (23/04/2021).</p>
Maximum number of deliveries	<p>The maximum number of services that can be ordered per meeting for a resource. (Default =1, Max. =9)</p>

Email Properties

Custom message	Select Yes to enable editor of the message in New reservation email
Message content	Message to be displayed in the New reservation email
Language	Click to enter translations in various language for the message.
Size, Color, Bold, Italic, Underline	Editing factors to compose the custom message.

Exchange Properties

Data in this section is synchronized from Exchange Server and cannot be modified.

Exchange Properties

Exchange Settings Synchronization Time
 ✔

All Request Out Of Policy
 Yes No

Request Out Of Policy

All Book In Policy
 Yes No

Book In Policies

All Request In Policy
 Yes No

Request In Policies

Allow Conflicts
 Yes No

Conflict Percentage Allowed

Maximum Conflict Instances

Booking Window In Days

Minimum Duration In Minutes

Maximum Duration In Minutes

Allow Recurring Meetings
 Yes No

Enforce Scheduling Horizon
 Yes No

Schedule Only During Work Hours
 Yes No

Forward Requests To Delegates
 Yes No

Tentative Pending Approval
 Yes No

The data can be automatically synchronized at a specific time which can be established in the parameter **MailBoxResources.StartTimeSync**. For more details about this parameter, please refer to **RC Parameter Guide**.

The properties provide an insight on how the resource is configured in Exchange and governs the policies of booking a resource. As Resource Central is integrated tightly with Exchange so settings of a resource need to be changed in Exchange, if you need the booking policy of a resource to change.

Based on this information, Resource Central also makes different validations and provide useful details when the system is being configured or when operating, e.g., showing conflicts in settings of resources belonging to the same virtual resources:

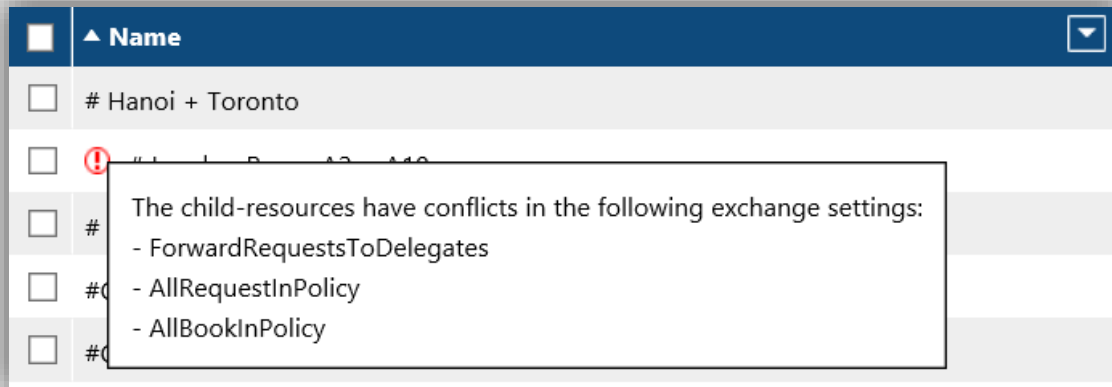

These values are Exchange Set-CalendarProcessing properties. If you want to learn more about these values, you can e.g. visit this [webpage](#).

Toolbar Buttons	Description
LIST	Takes you to the list of Resources
SAVE	Saves the data in the Input fields
RESERVATIONS	Displays all the reservations of the resource
RICH DESCRIPTION	Takes you to an HTML editor for the additional description of the resource
ASSIGNMENTS	Displays the current assignments of the resource
ITEMS	Displays the current items attached with the resource
SAVE CONFIGURATION	The values in all the fields will be saved so that the next time when the user clicks NEW to create a new resource, all of the fields will be pre-populated with those saved values (values in the 'Name' & 'Resource Mail' fields will not be saved).

NOTE: For a resource that has also been associated with a Virtual Resource, if you try to change the value of the 'Conflicting Meeting', 'Allow conflicts' * and/or 'Light Resource' input fields of that resource from the resource details screen, you will not be allowed to do so, and the following warning message will be displayed:

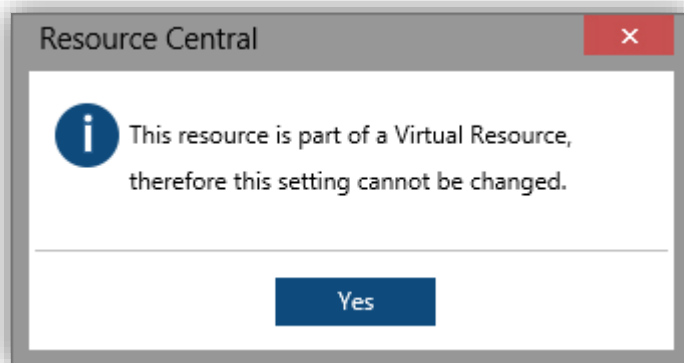

Figure 235. Warning message - When the user tries to change settings of an associated resource

Resource: Reservations

Click “Reservations” on the toolbar, all the Reservations of the current Resource will be shown:

Reservations for Resource 01

RESOURCE PRINT

Date	From	To	Subject	Organizer	Host	Is Recurring	Order
2023/10/17	08:30	08:45	Press Conference	lth@rcaod.onmicrosoft.com			
2023/10/19	09:15	09:30	Press Conference	lth@rcaod.onmicrosoft.com			
2023/10/19	09:45	10:00	Press Conference	lth@rcaod.onmicrosoft.com			✓
2023/10/20	10:00	10:15	Board Meeting	lth@rcaod.onmicrosoft.com			✓
2023/10/31	09:15	09:30	Board Meeting	lth@rcaod.onmicrosoft.com	Admin		✓
2023/11/01	09:30	09:45	Board Meeting	lth@rcaod.onmicrosoft.com			✓
2023/11/06	08:15	08:30	Internal Meeting	lth@rcaod.onmicrosoft.com			✓
2023/11/06	14:15	14:30	Internal Meeting	lth@rcaod.onmicrosoft.com	Admin	✓	
2023/11/07	14:15	14:30	Internal Meeting	lth@rcaod.onmicrosoft.com	Admin	✓	
2023/11/08	14:15	14:30	Internal Meeting	lth@rcaod.onmicrosoft.com	Admin	✓	
2023/11/09	08:00	08:15	Internal Meeting	lth@rcaod.onmicrosoft.com	Admin		
2023/11/11	09:00	09:15	Year-end Meeting	lth@rcaod.onmicrosoft.com			✓
2023/11/11	16:00	16:15	Year-end Meeting	lth@rcaod.onmicrosoft.com			
2023/11/11	17:00	17:15	Year-end Meeting	lth@rcaod.onmicrosoft.com	Admin		✓
2023/11/14	15:00	15:15	Client Meeting	dmn@rcaod.onmicrosoft.com			
2023/11/14	15:45	16:00	Client Meeting	dmn@rcaod.onmicrosoft.com			
2023/11/16	09:00	09:15	Client Meeting	lth@rcaod.onmicrosoft.com			
2023/11/25	10:30	10:45	Client Meeting	lth@rcaod.onmicrosoft.com			
2023/11/25	11:30	11:45	Client Meeting	lth@rcaod.onmicrosoft.com			
2023/11/28	11:15	11:30	Client Meeting	lth@rcaod.onmicrosoft.com			

First Page Previous 1 / 3 Next Last Page Go

Figure 236. Resource: List of Reservations for a Resource

Resource: Rich Description

Click **Rich Description**, the “Rich description editor” shows up:

Rich Description Editor

BACK SAVE PREVIEW

Source

B I U abc x₂ x² Styles Normal (...) Font Size

Resource Location

Figure 237. Rich description editor

Create any content you want in HTML text for this resource. The content you create here will be displayed in “**Further details**” area when you click this resource to see its details in ResourceFinder:

The screenshot displays the 'Resource Overview' table and the 'Details' panel for 'Meeting Room 001'. A red arrow points from the 'Meeting Room 001' checkbox in the table to the 'Further details' section in the details panel.

RESOURCE	CAPACITY	01:00 PM
<input type="checkbox"/> Meeting Room 001	5	
<input type="checkbox"/> Meeting Room 002	10	
<input type="checkbox"/> Meeting Room 003	7	
<input type="checkbox"/> Meeting Room 004	12	

Details

Resource Name:
Meeting Room 001

Light Resource:
No

Description:

Resource Mail:
resource1@rc37.com

Location:
Locations

Capacity:
5

Minimum Hours:
0

Further details:
Resource Location

Figure 238. Further details of the resource in ResourceFinder

The content in Rich Description can also be automatically input to the meeting invite body in order to help receiver acquire more details about the resource or the exact location of the resource. This function is controlled by the parameter **MeetingInvite.ResourceInfo.Enable** (refer to *RC Parameter Guide* for more details).

When this function is turned on, content in Rich Description of the resource selected in ResourceFinder will be displayed in the meeting invite body.

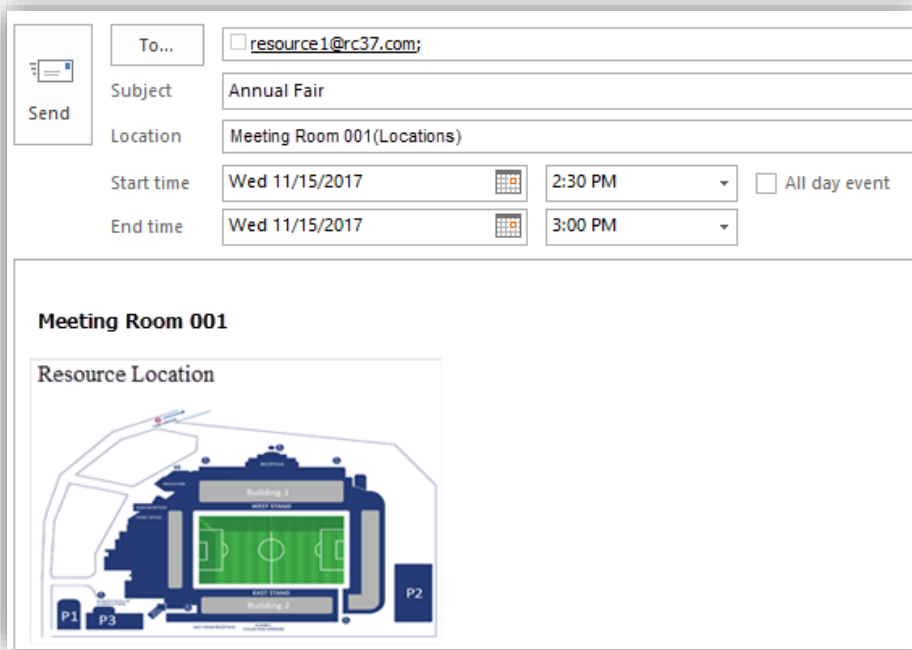

Figure 239. Meeting Invite – Rich Description input

NOTE: Apart from the map or image of the surroundings, you can also add text description of the resource location and URL so that attendees can link to a mapping service (e.g., Google Maps).

Resource: Assignments

Click “Assignments” on the toolbar, “Person/Role relations screen view will be opened. The Assignments view shows you the current person/role **combinations** related to the selected resource, as shown below:

Person/Role relations			Host (Security)
RESOURCE			
Role	Person	Source	Region
Catering	admin	Locations\Switzerland\Basel	
Events	admin	Locations\Switzerland\Basel	
Facility	admin	Locations\Switzerland\Basel	
Catering	Catering	Locations\Switzerland\Basel	
Facility	Facility	Locations\Switzerland\Basel	
Catering	Host (Security)	Locations\Switzerland\Basel	World
Events	Host (Security)	Locations\Switzerland\Basel	World
Facility	Host (Security)	Locations\Switzerland\Basel	World
Host(Security Role)	Host (Security)	Locations\Switzerland\Basel	World
Reception	Host (Security)	Locations\Switzerland\Basel	World

Figure 240. Resource: Assignments for a Resource

Toolbar Buttons	Description
Resource	You can go back to the Resource Details window

Resource: Items

In Resource Central system the items and their responsible roles/persons are defined through Daily Tasks section in Resource Central Admin interface. However, in order to use these items in additional services of Order Form, these items must be assigned to a resource.

This view shows the items assigned to the selected resource. Use **[Add Item]** button to add another item. Mark the items with a checkbox next to the item and select **[Delete]** to delete the relation. Click **[Resource]** to return to the resource view.

NOTE: Item Resource Association screen has also been made role-based, as per the Location(s) of the logged in person.

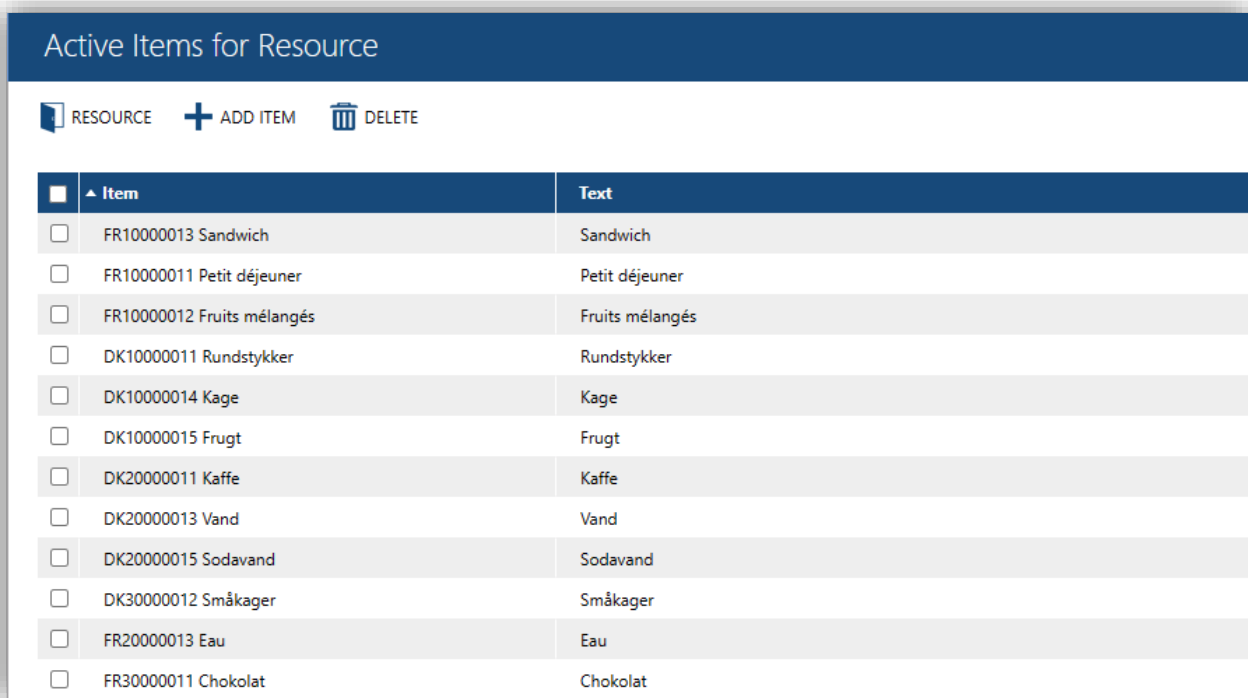

Figure 241. Resource: List of Items available with the Resource

“Item” column refers to Number field in item details.

“Text” column refers to Name field in item details.

Toolbar Buttons	Description
Resource	You can go back to the Resource Details window
Add Item	You can add items from the list of all items
Delete	You can remove the selected items

NOTE: For resource using SOF, **Item** view will be removed from the toolbar of resource details:



Resource Bulk Update

Resource Central allows you to update multiple resources at the same time by selecting resources you want to update and clicking **[Bulk Update]** button on the toolbar:



Figure 242. Resources mass update button

Resources bulk update panel basically consists of 2 columns: **Field** and **Value**.

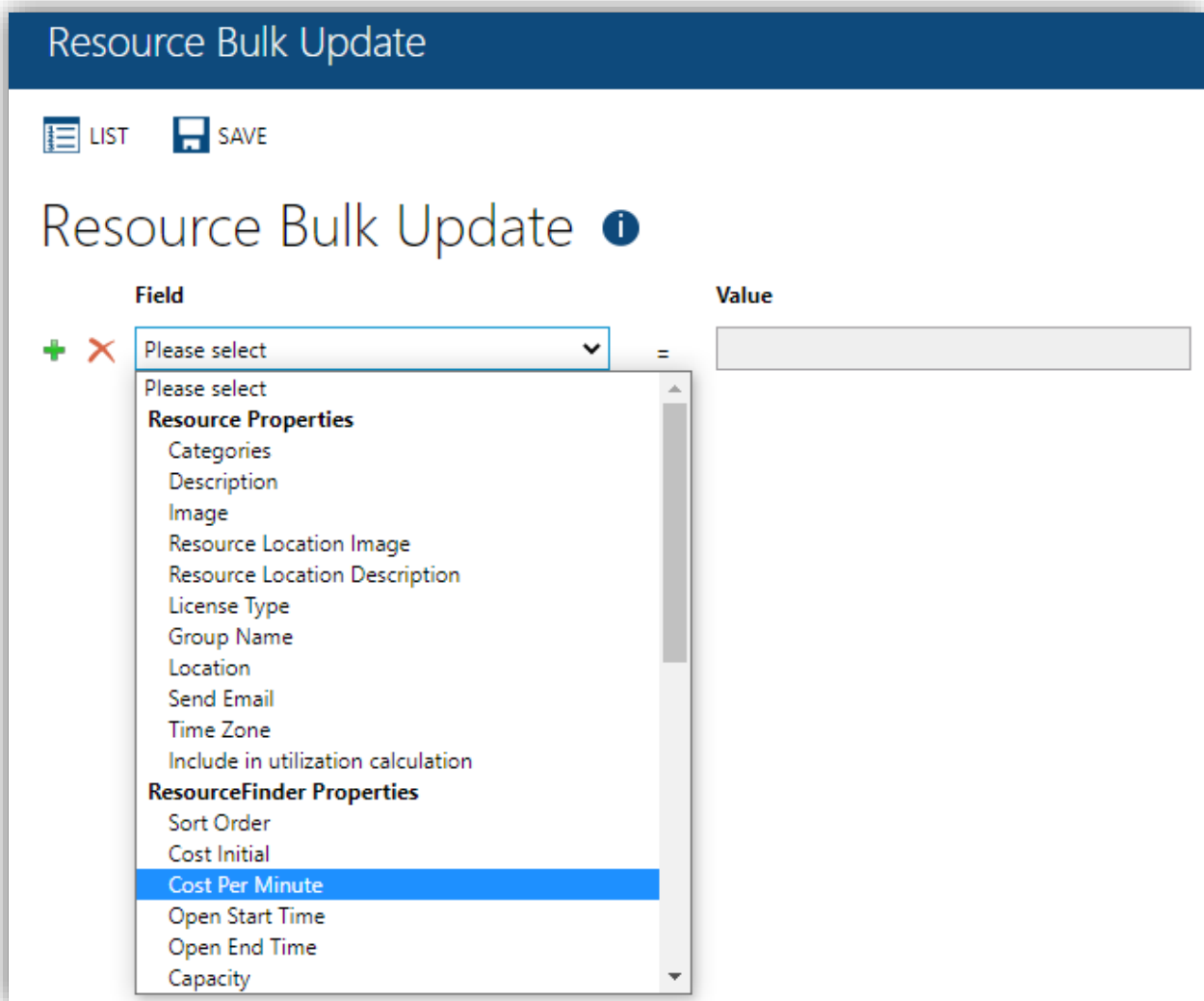



Figure 243. Resources mass update panel

In the **Field** column, you can add more fields you want to update to the selected resources by clicking **[+]** button and selecting a specific field from the drop-down list. Click on the arrow button to open the drop-down list and all fields in a resource's details are displayed for you to select.

After selecting the field, you can fill in **Value** column with the relevant inputs.

IMPORTANT NOTE:

- Updating existing resources will overwrite the already saved information on all the selected, so keep in mind that all needed values need to be reselected when updating multiple resources.
- The bulk-updated value cannot be applied to data fields with Locked icon .

Click [**Save**] to finish.

Import multiple resources

In case you want to create a lot of resources with common details at the same time, you can do that by clicking [**Import**] button on the toolbar:



Figure 244. Import multiple resources

After clicking the button, a panel similar to a resource’s details will be displayed:

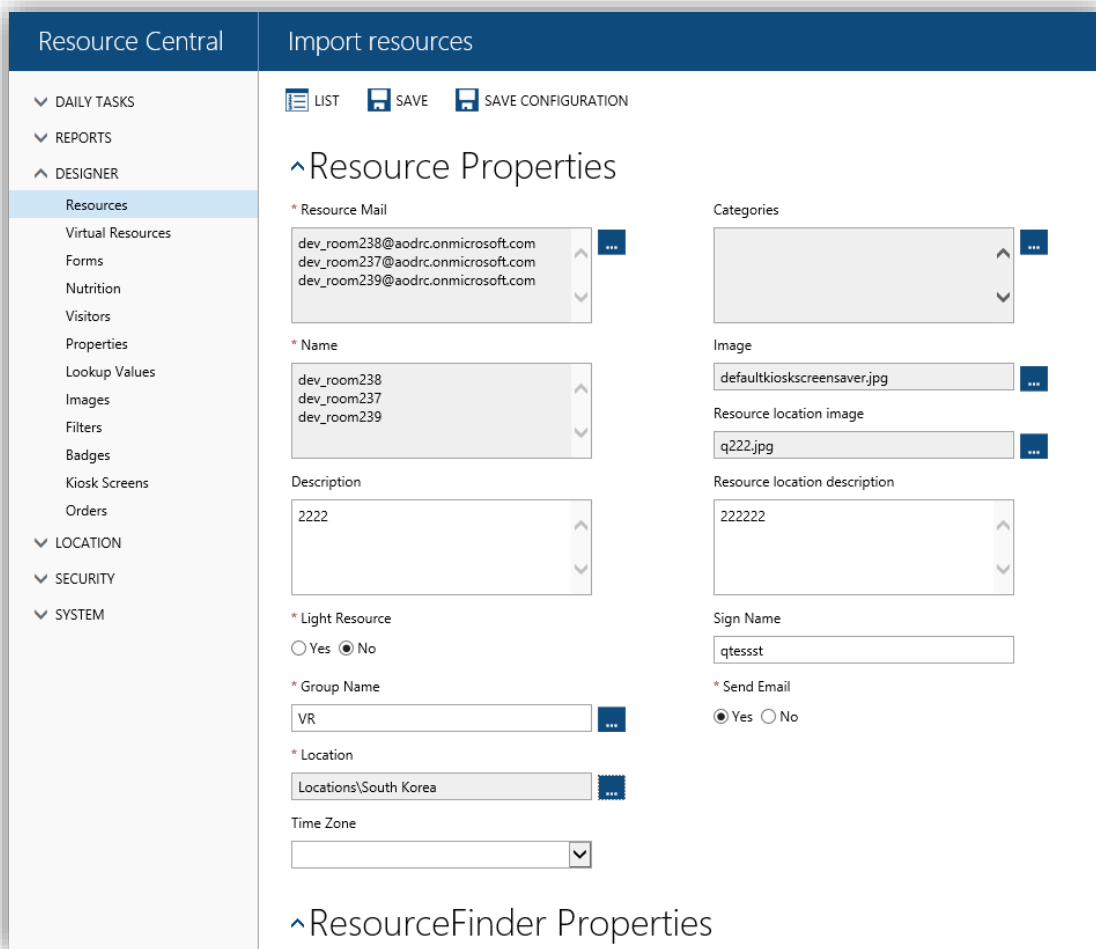

Figure 245. Import multiple resources

Fill in the details of the resources you want to create, especially the required fields. Then click [Save], and all these new resources are created and imported to the resource list.

Toolbar Buttons	Description
List	Go to resources list
Save	Finish creating multiple resources
Save Configuration	Save the details you fill in the panel for later use

Close Resource

In some cases, resources need to be closed for several reasons. To activate this feature, set the parameter **RC.ClosedPeriod** is set to '1' (refer to **Resource Central Parameter Guide** for more details).

You can close individual resource via a Resource's details → **ResourceFinder Properties**. There you will see 3 properties: **Notification of Closing Date**, **Closing Date**, and **Opening Date** (refer to [Resource Details](#)).

After selecting dates for each field above and click [**Save**], the closure period will be applied to the resource.

As a result, organizers cannot book the resources within the closure period. The warning icons will be shown on ResourceFinder as follows:

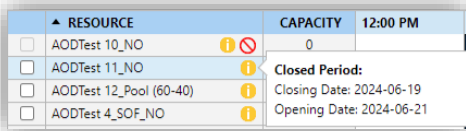

Figure 246. Warning before closing date

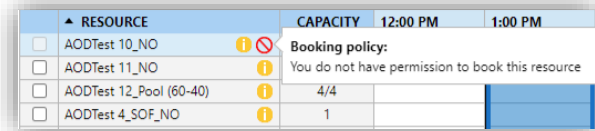

Figure 247. Warning during closing & opening date

If the resource is closed permanently as of the Closing Date, warning icons will be shown on ResourceFinder as follows:

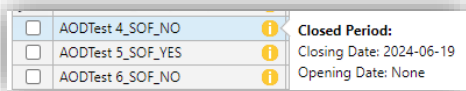

Figure 248. Warning before closing date

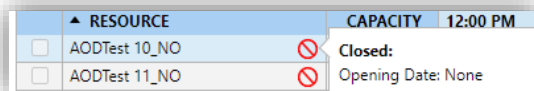

Figure 249. Warning within closing date

If there are resource(s) already booked within the closure period, clicking [**Save**] will send the following email to the organizer who booked the resource(s).

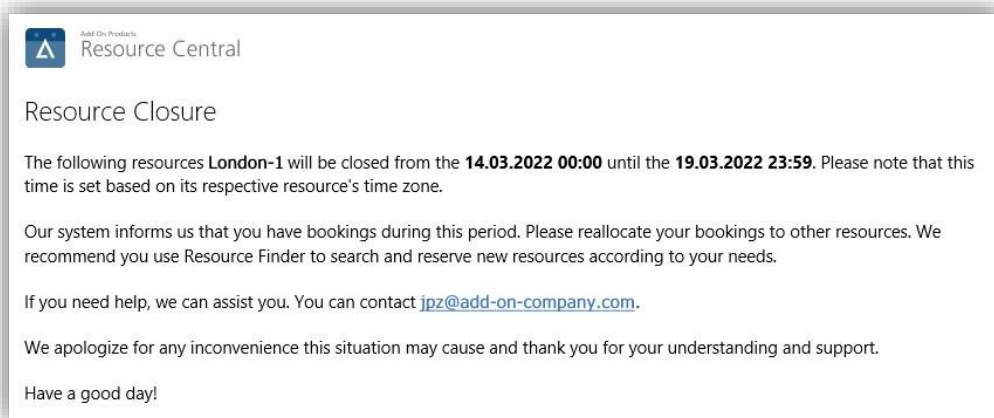

Figure 250. Resource closure notification



The email will include contact information if it is specified in the 'Close Location' page of the location that includes the closed resource. (Refer to [Close Location](#) for more details on adding Contact information)

This will not cancel the meeting, but its organizer needs to change the booked resource, or select a different meeting date that is outside the closure period.

You can also close multiple resources using **[Bulk Update]**.

On Resource Bulk Update panel, select either **Notification of Closing Date**, **Closing Date**, or **Opening Date**. Choosing one will add all those 3 fields as they are mandatory for this setup.

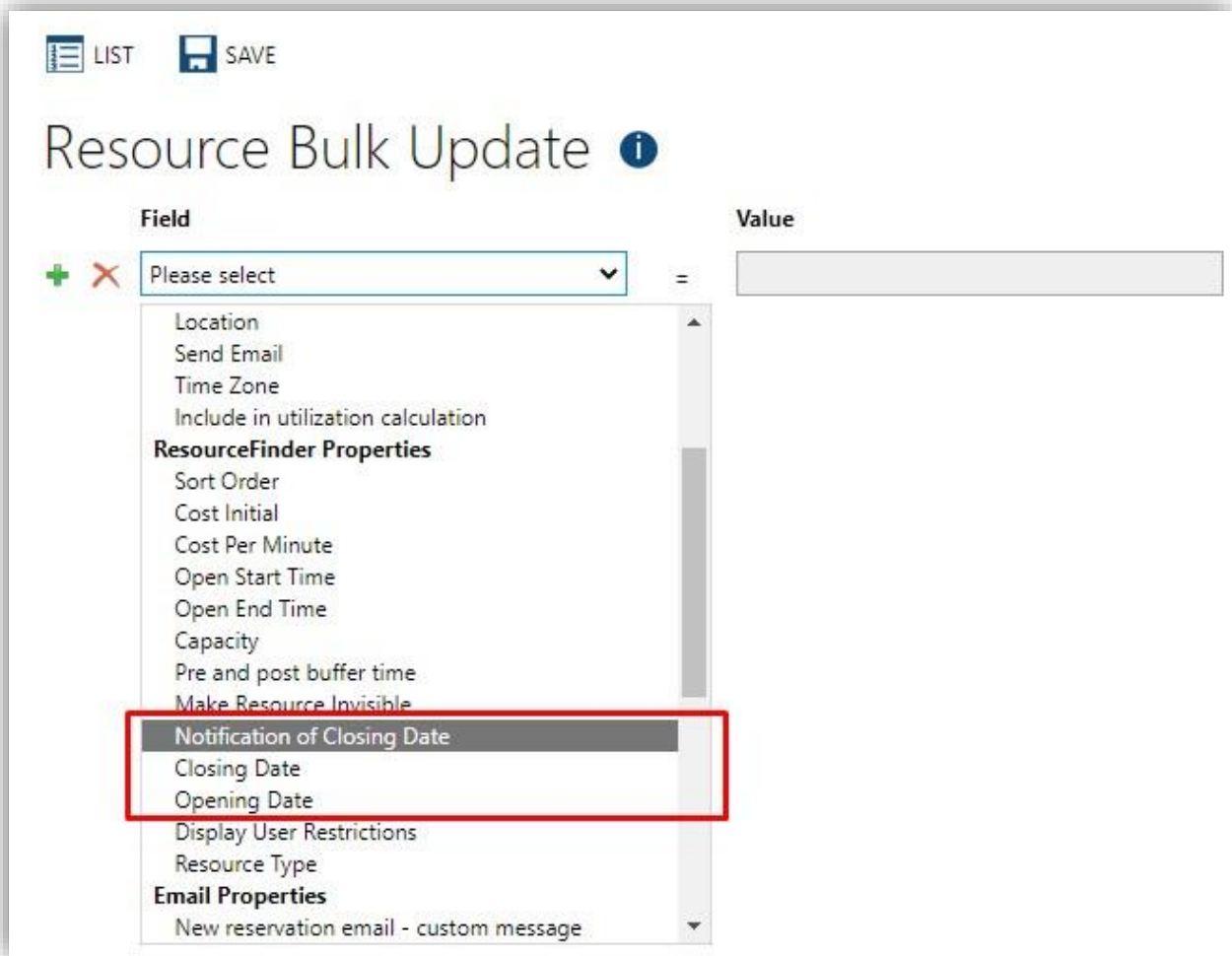

Figure 251. Select closing date field

Simply select dates for each field then click **[Save]** to finish. The closed period will be applied for all selected resources.

NOTE 1: If the resources belong to a location that already has a closed period, those resources will follow the period of their respective location. Also, those resources cannot set closure period individually (refer to [Close Location](#)).

NOTE 2: If a resource changes to a new location, there are two possible scenarios:

- New location has its own closure period: the resource will follow its new location's closure period.
- New location does not have closure period: the resource will be removed.

Examples of scenarios when booking closed resources

Scenario 1: Booking or changing a meeting

- The booking date (the day organizer makes the booking) is within the notification period (from Notification of Closing Date to Closing Date).
- The meeting date(s) (the time of the actual meeting) is within closure period.

→ **Result:** The reservation(s) is accepted, but organizer will receive resource-closure notification email (Figure 237).

Scenario 2: Booking or changing a meeting

- The booking date is within the closed period.
- The meeting date(s) is within the closed period.

→ **Result:** The meeting is declined due to closed resource(s).

Scenario 3: When you book a recurring meeting, if:

- The booking date is within the closed period.
- There are recurring dates that are within the closed period.

→ **Result:** The meeting is accepted; however, reservation in recurring date(s) within closure period is declined.

Virtual Resources

‘Virtual Resource’ screen contains all your defined Virtual Resources. The concept behind Virtual Resource is to enable user to create a Resource (Virtual Resource) by grouping several already created resources in the RC system. The virtual resource will not have its unique email address, but it will act as an Individual Resource in the Resource Central.

When you click the ‘Virtual Resources’ tree node, all the created virtual resources will be listed in the right pane, as shown below:

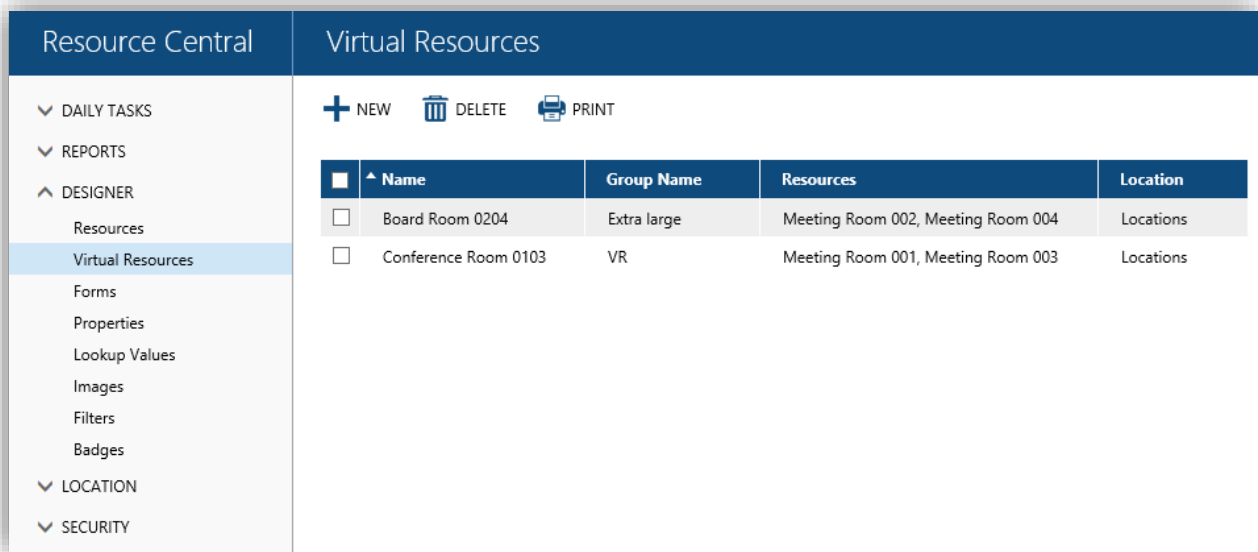

Figure 252. Virtual Resources Summary Screen

Toolbar Buttons	Description
Add	Add a New virtual resource
Delete	Delete a selected virtual resource
Print	Print the virtual resources on the screen

When you click on any of the listed Virtual Resources, the details of that virtual resource will be displayed.

Virtual Resource Functionality:

- The created virtual resources will have the same functionality as that of other resources in Resource Central.



- At ResourceFinder, the virtual resources will be listed, along with all of the other resources. User can select any virtual resource from the ResourceFinder to make booking over it. The TimeLine grid against the virtual resource will be shown as Occupied/Free as per the Reservations' Information. Same is true in the case of **Daily Tasks → Overview** section.
- If a reservation has been placed over a Virtual Resource, then at the ResourceFinder Time Line grid, that Virtual Resource and all its associated resources will be shown as BOOKED for that particular timeslot.
- The reservation over a Virtual Resource will be displayed as a single reservation at **Daily Tasks → Reservations** and **My Meetings**.
- If one of the resources that composes the virtual resource has Delegate Function value = Yes, it can be considered that the virtual resource has Delegate Function value = Yes.

NOTE: You will not be allowed to delete from **Designer → Resources** section a resource that is part of a Virtual Resource, and the following message will be displayed:

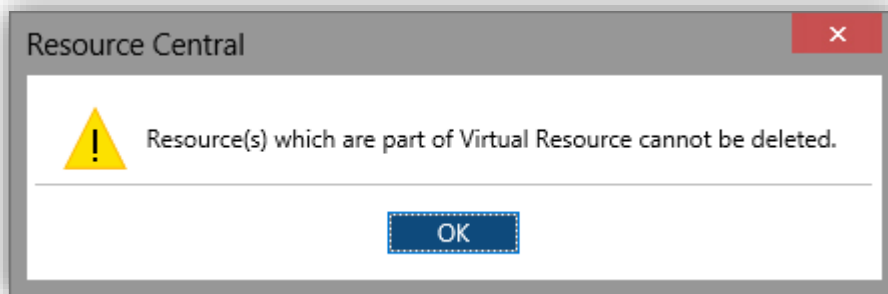

Figure 253. Associated Resources Deletion Message

Virtual Resource Detail

From the virtual resource detail view, you can **edit** and **save** the record, enter description for the virtual resources in **HTML** format using the built-in editor. You can **view** which person/roles are assigned to this virtual resource. You can also **edit** the list of items related to the virtual resource.

Field	Description
Virtual Resource Properties	
<div style="border: 1px solid #ccc; padding: 10px;"> <h3>Virtual Resource Properties</h3> <div style="display: flex; justify-content: space-between;"> <div style="width: 45%;"> <p>* Name</p> <input type="text" value="# Hanoi + Toronto"/> <p>Description</p> <input type="text" value="Books both Hanoi + Toronto."/> <p>* Group Name</p> <input type="text" value="Meeting Rooms"/> <p>* Location</p> <input type="text" value="Locations\Add-On Products HQ"/> <p>Time Zone</p> <input type="text" value="(UTC+01:00) Brussels, Copenhagen, Madrid, I"/> <p>* Resources</p> <div style="border: 1px solid #ccc; padding: 5px;"> # Meeting Room Hanoi # Meeting Room Toronto </div> </div> <div style="width: 45%;"> <p>Categories</p> <div style="border: 1px solid #ccc; padding: 5px;">Virtual rooms</div> <p>Image</p> <div style="border: 1px solid #ccc; height: 20px;"></div> <p>Resource location image</p> <div style="border: 1px solid #ccc; height: 20px;"></div> <p>Resource location description</p> <div style="border: 1px solid #ccc; height: 40px;"></div> <p>Sign Name</p> <input type="text"/> <p>* Send Email</p> <input checked="" type="radio"/> Yes <input type="radio"/> No </div> </div> </div>	

Name	A friendly name for the virtual resource. (mandatory)
Description	Description of the virtual resource
Group Name	Group Name can be used for categorizing the virtual resources. Whenever you are viewing the “ Orders ”, “ Reservations ” or “ Overview ” in the Daily Tasks section, you have the option of filtering the data by group. The group is also used in the Report section, allowing you to segment reports based on group intervals
Location	Select the location of virtual resource (mandatory) The location must be defined in ‘ Location ’ tree under Location node.
Time Zone	Time Zone of the virtual resource so as to convert the reservation & serving times accordingly over the specific areas
Resources	List Box accompanied with a Lookup button. When you click the Lookup, a new window will open which will contain the Names of all the Resources, as per Locations, which have been created in the system, so that you can select a resource combination to be associated with the Virtual Resource
Categories	Select categories of virtual resource. The categories must be defined in ‘ Location ’ tree under Categories node

Image	Select/de-select an image of the virtual resource. This image will be displayed in ResourceFinder and the Order form.
Resource location image	Refer to Logistics and delivery management section in <i>Resource Central Provider Guide</i> for more knowledge on how to use these features
Resource location description	
Sign Name	This is name of the virtual resource which will be exported in XML file of Signage
Send Email	Select YES if you want to allow emails to be sent for a resource or not. If you select NO, then the Organizer and/or the Service Provider(s) would not get any email(s) regarding the changes of the reservation of this resource. NOTE: This option does not apply for emails on Shared Orders
ResourceFinder Properties Refer to section Resource Properties in Resource's details	
Order Flow Properties Refer to section Order Flow Properties in Resource's details	
Email Properties Refer to section Email Properties in Resource's details	

Toolbar Buttons	Description
LIST	Takes you to the main Summary page of Virtual Resources
SAVE	Saves the data in the Input fields
RESERVATIONS	Displays all the reservations of the virtual resource
RICH DESCRIPTION	Takes you to an HTML editor for the additional description of the virtual resource
ASSIGNMENTS	Displays the current assignments of the virtual resource
ITEMS	Displays the current items attached with the virtual resource
SAVE CONFIGURATIONS	The values in all of the fields will be saved so that the next time when the user clicks NEW to create a new resource, all of the fields will be pre-populated with those saved values (values in the 'Name' & 'Resource Mail' fields will not be saved).

Virtual Resource: Reservations

Click Reservations, all the reservations of the current virtual resource will be displayed:

From	To	Resource	Subject	Organizer	Is Recur...	Location
06-07-2016 09:00	06-07-2016 09:30	Conference Room 0103	Annual Board Meeting	Administrator@rc37.com		Locations
06-07-2016 04:00	06-07-2016 04:30	Conference Room 0103	Press Conference	Administrator@rc37.com		Locations

Figure 254. Virtual Resource Reservations

Toolbar Buttons	Description
Resource	You can go back to the Resource Details window
Print	Print all reservations on the screen

Virtual Resource: Rich Description

Rich Description of a virtual resource is similar to that of a normal resource. Refer to [this section](#) for more details.

Virtual Resource: Assignments

The Assignments view shows you the current person/role **combinations** related to the selected virtual resource, as shown below:

The screenshot shows a window titled 'Person/Role relations' with a sub-header 'RESOURCE'. Below this is a table with four columns: Role, Person, Source, and Region. The table contains four rows of data.

Role	Person	Source	Region
admin	admin	Locations	
admin	admin	Locations\VR locatio	
Booking Manager	Booking Manager	Locations	
Booking Manager	Booking Manager	Locations\VR location	

Figure 255. Virtual Resource Assignments

Toolbar Buttons	Description
Resource	You can go back to the Resource Details window

Virtual Resource: Items

In Resource Central system the items and their responsible roles/persons are defined through Daily Tasks section in Resource Central Admin interface. However, to use these items in additional services of order form for a virtual resource, these items must be assigned to that particular virtual resource.

This view shows the items assigned to the selected virtual resource. Use [**Add Item**] button to add another item. Mark the items with a checkbox next to the item and select [**Delete**] to remove the relation. Click [**Resource**] to return to the virtual resource details view.

NOTE: The Item Resource Association screen has also been made role-based, as per the Location (s) of the logged in person.

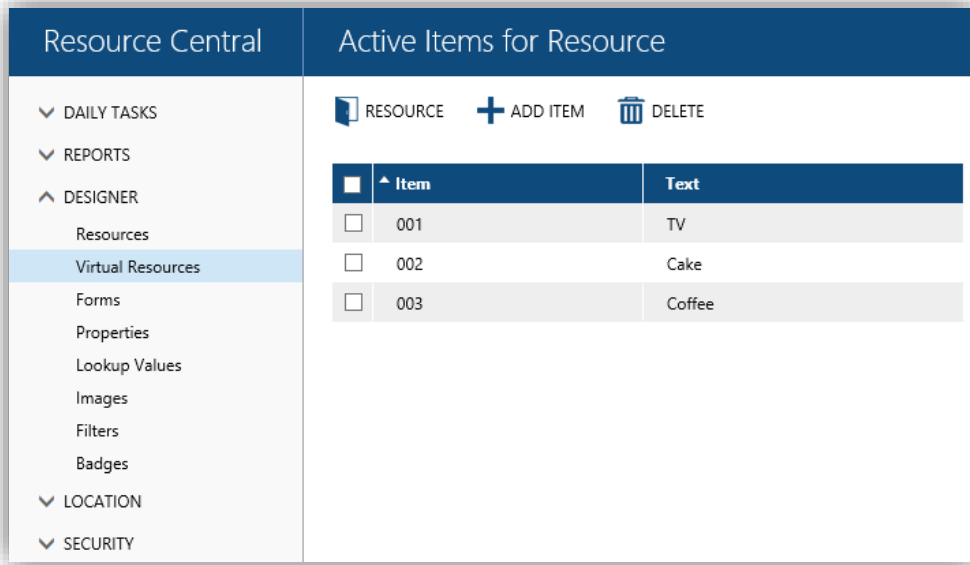
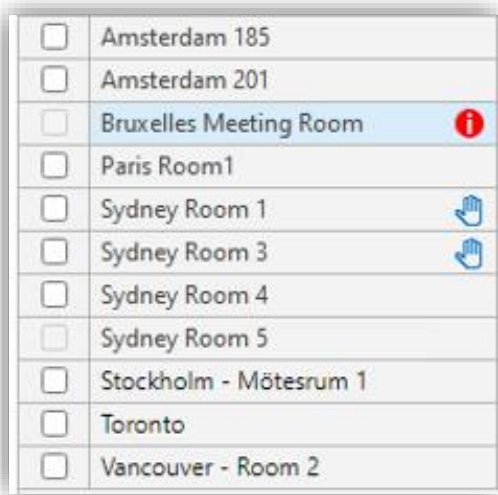

Figure 256. Virtual Resource Items

Toolbar Buttons	Description
Add Item	You can add items from the list of all items
Delete	You can remove the selected items
Resource	You can go back to the Resource Details window



Virtual Resource: Booking Permission

Virtual Resource’s Booking Permission depends on each child resource’s permissions. These permissions can be seen on, for example, on ResourceFinder:



Each icon represents a permission type described as follows:

Icon	Permission Type	Meanings
	Declined	You cannot book this resource due to your booking request’s conflict with the resource’s booking policy

	Declined	You cannot book this resource due to your lack of permission to book the resource
	Tentative	You can book this resource, but your booking request will require approval by the resource's delegate
	Accepted	You can book this resource, and your booking request will be accepted. But be aware of the conflicted occurrences
No icon	Accepted	You can book this resource, and your booking request will be accepted

In case of Virtual Resource, Resource Central will consider all child resource's permissions and give a booking permission for the Virtual Resource based on the following priorities: **Declined → Tentative → Accepted**.

The resources' permission settings can be seen under **Designer/Resources/Exchange Properties**:

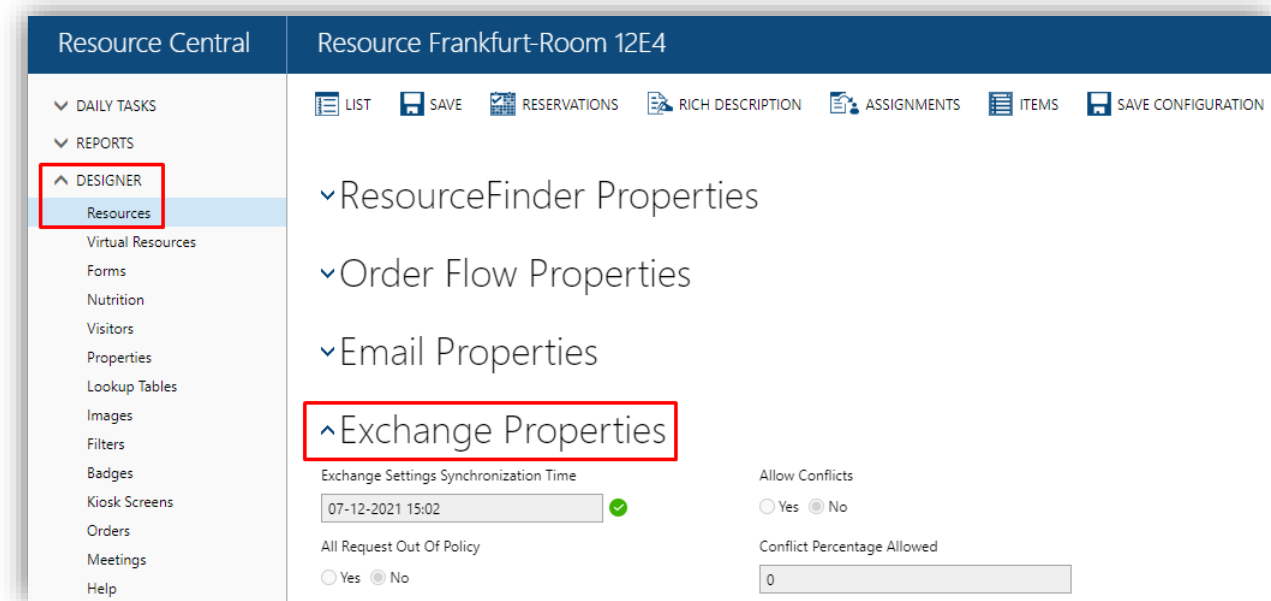

This means Virtual Resource's booking permission will take after the child resource's permission with highest priority. Below is an example of a Virtual Resource with 2 child resources:

Child Resource's Booking Permissions	Virtual Resource's Booking Permissions
Accepted Accepted	Accepted
Accepted Tentative	Tentative
Accepted Declined	Declined
Tentative Tentative	Tentative
Tentative Declined	Declined
Declined Declined	Declined

NOTE: If the Virtual Resource’s booking permission shows , it means the Virtual Resource is still bookable and the booking request will be accepted. But be aware of the conflicted occurrences.

Close Virtual Resource

Like normal resource, you can also set closure period for Virtual Resource. The way it works and configures is similar to normal resource (refer to [Close Resource](#) for more details).

NOTE: If a virtual resource has closure period, this does NOT affect its child resource (meaning the child resources are still available).

Forms

In order to enable you to **extend** the **Resource Central Order Form**, you can define your own forms, or you can also **customize** the already created forms. Forms can contain fields that link to properties and are integrated into the order form.

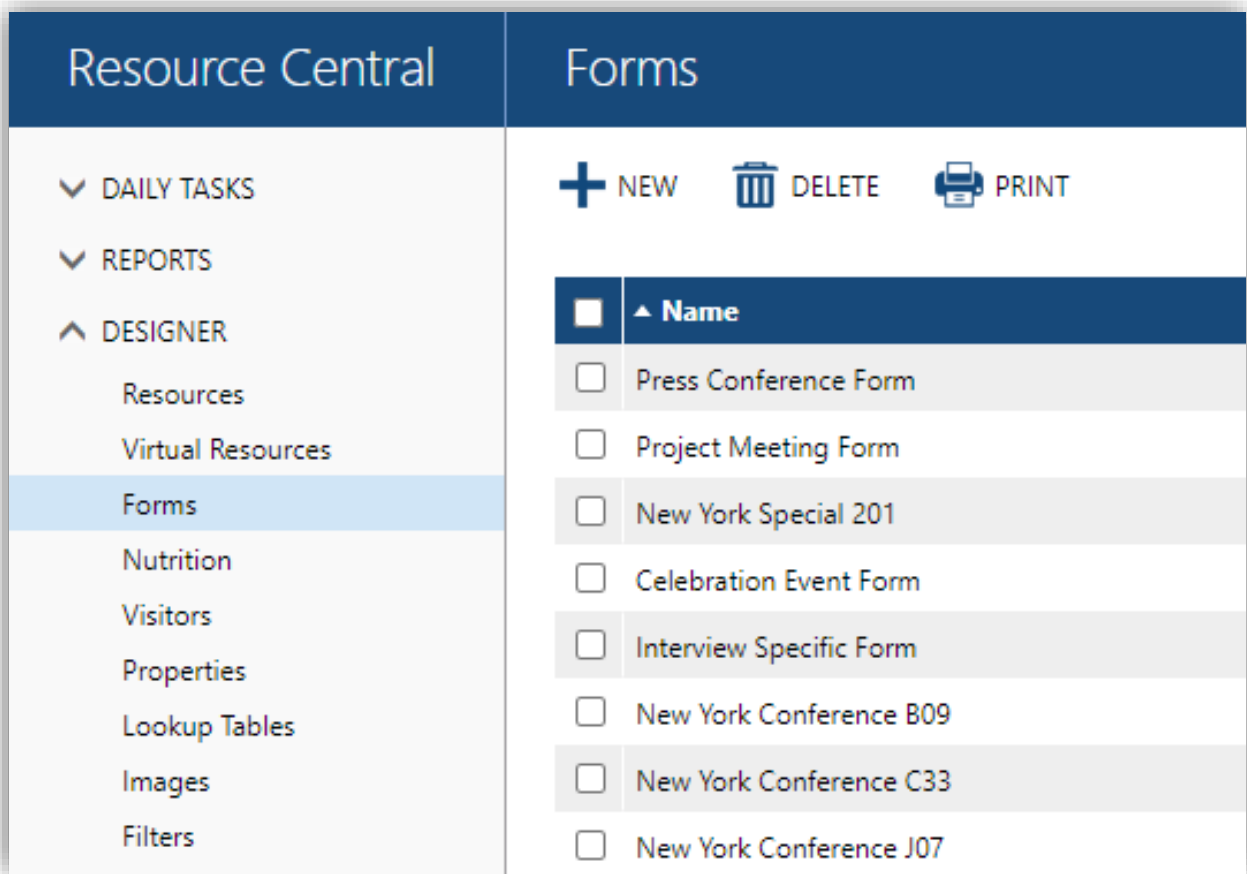

Figure 257. List of Forms

Toolbar Buttons	Description
New	Create a New Form
Delete	Delete a selected Form
Print	Print all the Form name on the screen

Clicking one of the forms will show details about it.

Form details

Viewing a given form, you can **change** the **name** and **description** or edit the form, as shown below:

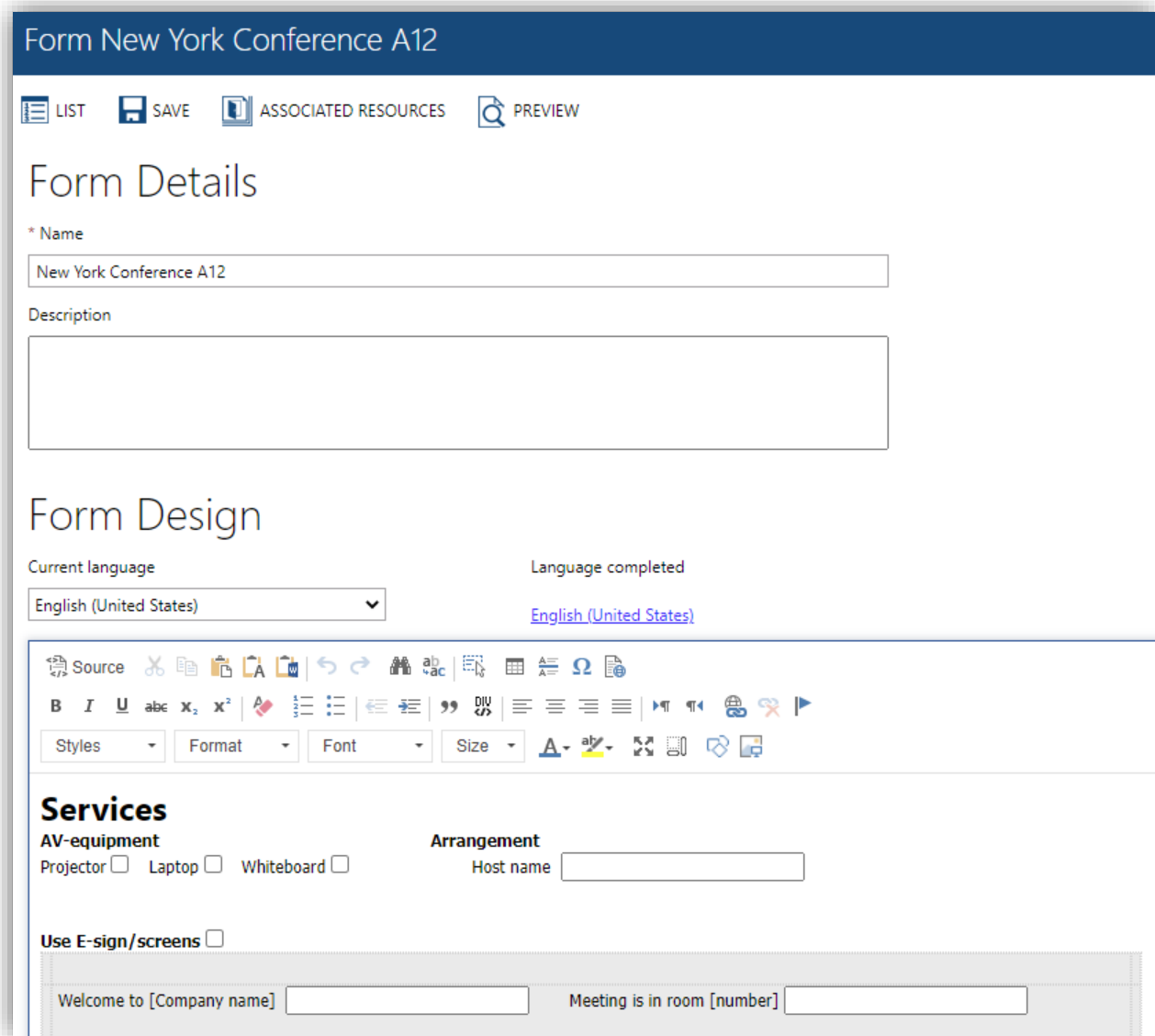

Figure 258. Details of a Form

Field	Description
Name	Used for identification of this record in other forms
Description	A short description. Max 255 characters
Form Design	Used to edit the form.

Toolbar Buttons	Description
LIST	Displays the list of forms
SAVE	Save the changes made in the input fields
ASSOCIATED RESOURCES	Open list of resources that use this order form
PREVIEW	The preview section of the form content that would be shown on the resource's Order Form.

NOTE: You just can select another language in “**Current language**” dropdown list after creation of the first form. Only Shared order Form supports multi-languages.

If you insert images, please note that only **Images** available at **Designer → Images** could be inserted. If any of the inserted images is **deleted** from this path, it will not be shown on the specified form.

Edit Form

The Form Design section allows you to edit your form content which would be shown on the resource’s Order Form.

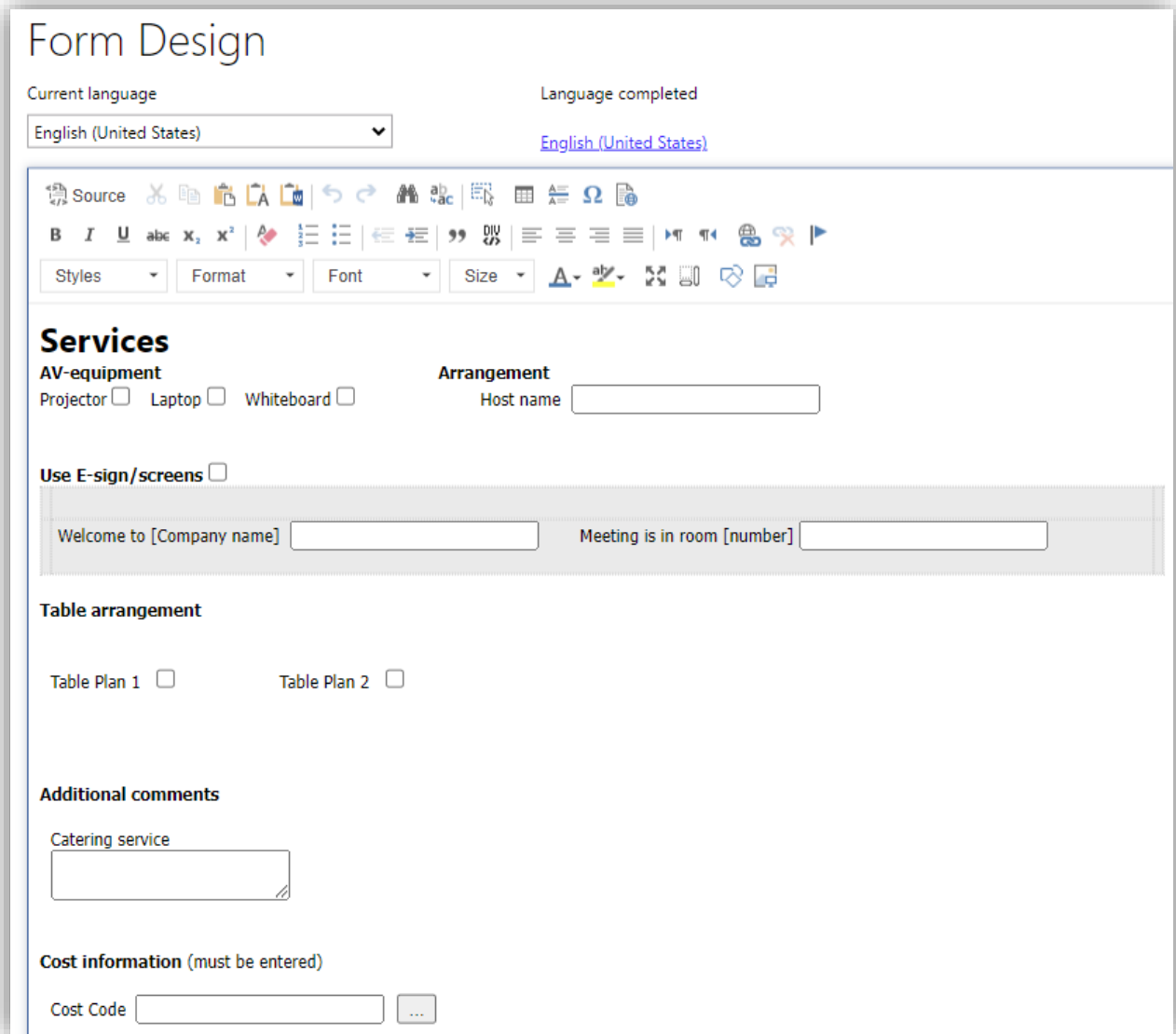

Form Design

Current language: English (United States) | Language completed: English (United States)

Services

AV-equipment: Projector Laptop Whiteboard Arrangement: Host name

Use E-sign/screens

Welcome to [Company name] Meeting is in room [number]

Table arrangement

Table Plan 1 Table Plan 2

Additional comments

Catering service

Cost information (must be entered)

Cost Code

Figure 259. Form Editor

Edit Form: Inserting properties

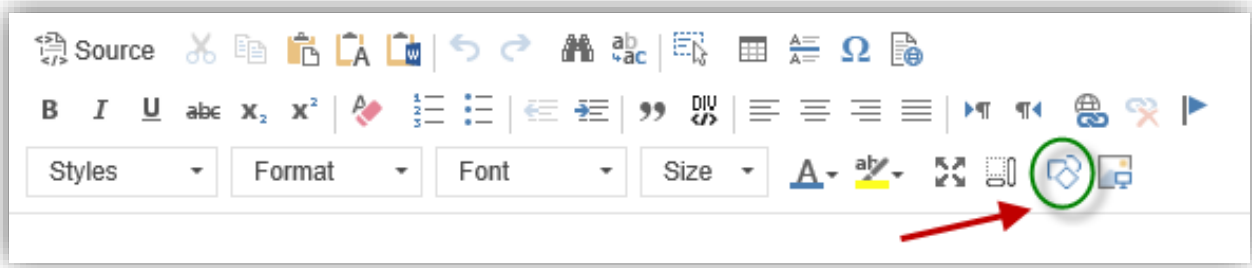

Figure 260. Insert Property icon

Selecting "Insert Property" icon will make an "Insert Property dialog" popup. You can select a property from the list of defined properties and specify what kind of field that the property can be edited in.

Click **OK** to insert the selection.

Properties are maintained in the **Designer → Properties** section:

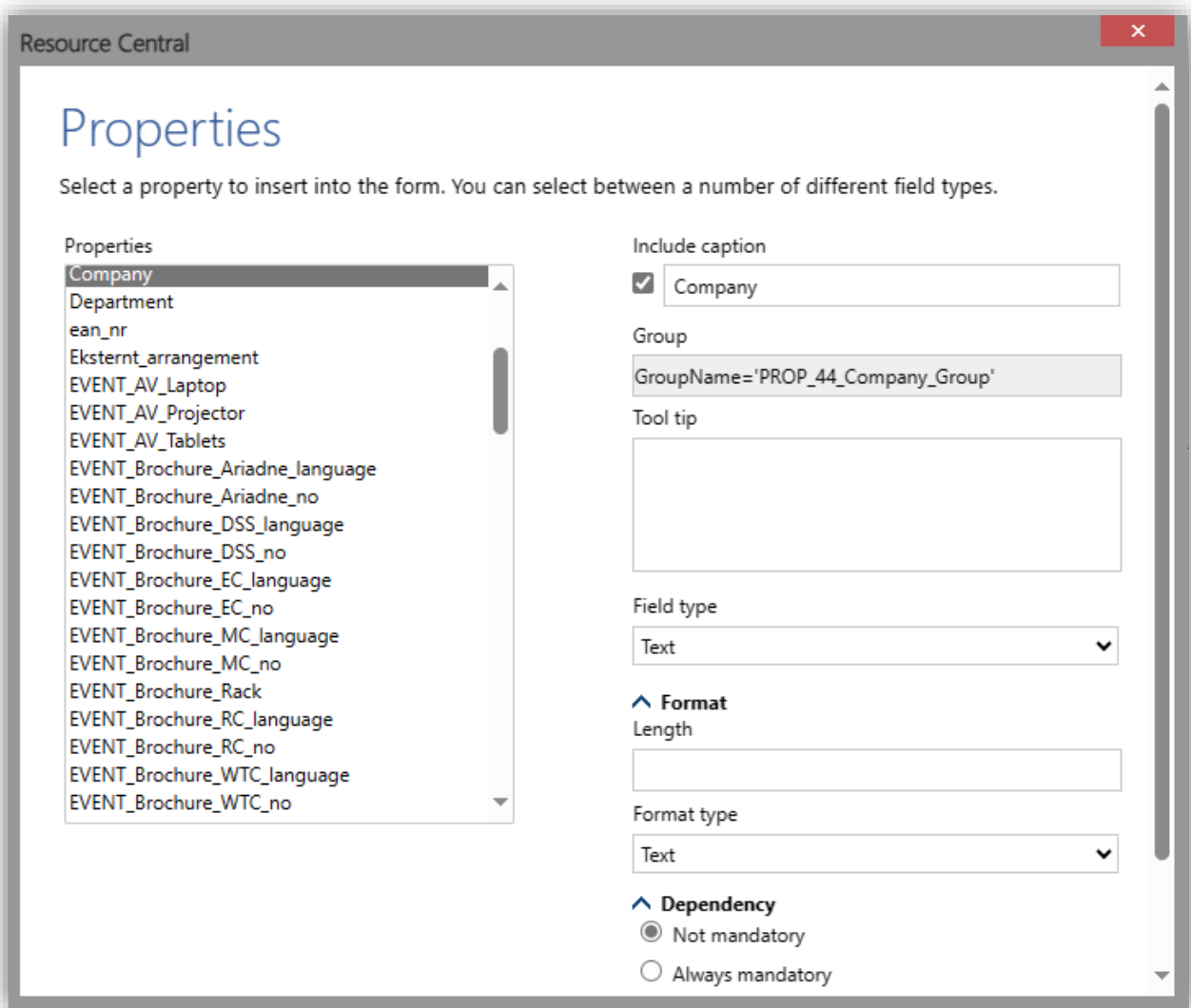

Figure 261. Forms: Inserting Property to a Form

Field	Description
-------	-------------

Properties	All the defined properties in the application
Include caption	A checkbox to include the caption on the form
Group	Group of the property
Tool tip	Enter tool tip which will be shown when you roll the mouse over that property field in the form
Field type	Select the type of control for the selected property
Format	Select the length and the format type for the properties (the format type can be Text/Date/Number/Email/Special)
Dependency	Decide whether fields related to this property are required or not to be filled in on the form

Edit Form: Creating a Drop down (Combo) Property

Resource Central also provides users with the functionality to associate their existing Properties in Order Form of a resource as a Drop down box (Combo box) property, thus enabling users to select a single value from the drop-down list.

When you click the **[Insert Property]** button, the **Insert Property** screen will appear. In the Field type, select "Drop Down List" as shown in the figure below:

The screenshot shows the 'Properties' dialog box in Resource Central. The title bar reads 'Resource Central'. The main heading is 'Properties'. Below the heading, it says 'Select a property to insert into the form. You can select between a number of different field types.'

On the left, there is a list of properties under the heading 'Properties'. The list includes: Company, Department, ean_nr, Eksternt_arrangement, EVENT_AV_Laptop, EVENT_AV_Projector, EVENT_AV_Tablets, EVENT_Brochure_Ariadne_language, EVENT_Brochure_Ariadne_no, EVENT_Brochure_DSS_language, EVENT_Brochure_DSS_no, EVENT_Brochure_EC_language, EVENT_Brochure_EC_no, EVENT_Brochure_MC_language, EVENT_Brochure_MC_no, EVENT_Brochure_Rack, EVENT_Brochure_RC_language, EVENT_Brochure_RC_no, EVENT_Brochure_WTC_language, and EVENT Brochure WTC no. 'Company' is selected.

On the right, there are several form fields:

- 'Include caption' with a checked checkbox and a text box containing 'Company'.
- 'Group' with a text box containing 'GroupName='PROP_44_Company_Group''.
- 'Tool tip' with an empty text box.
- 'Field type' with a dropdown menu set to 'Drop Down List'. This field is highlighted with a red rectangular box.
- 'Table name' with a dropdown menu set to 'Title'.
- 'Dependency' with three radio button options: 'Not mandatory' (selected), 'Always mandatory', and 'Mandatory when dependency is true'.

At the bottom of the dialog, there are 'OK' and 'Cancel' buttons.

Figure 262. Forms: Inserting Property as a Drop Down list

Edit Form: Preview

When you click [**Preview**] button on the toolbar, it will open the form preview screen similar as below:

The screenshot displays the 'Form Preview' interface within the Resource Central application. At the top, there are several configuration options: 'Enable dependency' is checked, 'Number Of Serving' and 'Total Amount' are input fields, and 'Visitor' is an unchecked checkbox. Below these are 'Apply' and 'Reset' buttons. The main content area is titled 'Form Preview' and contains the following sections:

- Services:**
 - AV-equipment:** Projector , Laptop , Whiteboard
 - Arrangement:** Host name
- Use E-sign/screens:**
- Text area:** Welcome to [Company name] Meeting is in room [number]
- Table arrangement:**
 - Table Plan 1
 - Table Plan 2
- Additional comments:**
 - Catering service
- Cost information (must be entered):**
 - Cost Code

Figure 265. Form preview

This screen lets you preview the form that you have edited. Here you can test the form to make sure that it works as intended.

There are 4 conditions that you can apply, including:

- **Enable dependency:** makes the dependent properties hidden on the preview if its required conditions are not fulfilled yet (refer to [Dependency function](#)).
- **Number of Serving:** enter an amount of servings
- **Total Amount:** enter a total amount of all servings
- **Visitor:** enable visitors

When you filled in the conditions, click [**Apply**] to see how it works on the preview. You can also click [**Reset**] to revert all conditions.

Associated Resources

When clicking [**Associated Resources**] button, a pop-up window shows up with a list of resources in which the form is used:



Resources	Shared Order Form
Meeting Room 002	No
Meeting Room 003	No

Figure 266. Associated resources of a form

If this form is not used by any resource, the following message shows up when you click [**Associated Resources**] button:

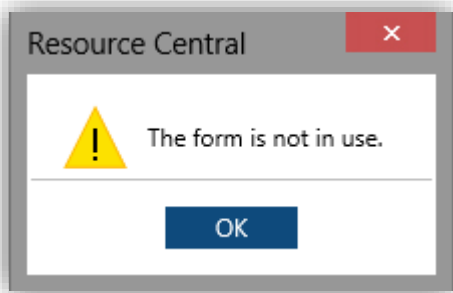

Figure 267. Form not in used - message

Nutrition

In this section, you can make configuration for adding nutrition information to items in the system.

Resource Central | **Nutrition information set up**

▼ DAILY TASKS

▼ REPORTS

▲ DESIGNER















- Resources
- Virtual Resources
- Forms
- Nutrition**
- Visitors
- Properties
- Lookup Values
- Images
- Filters
- Badges
- Kiosk Screens
- Orders

▼ LOCATION

▼ SECURITY

SAVE

Sections

- Nutrition facts  
- Allergies  
- Meal Type  
- Vitamins  
- Minerals  
- Sterols  
- Testing section  









Add

▲ Nutrition facts

Data type

Numeric 

Data labels

- Kcal  
- Sodium  
- Carbs  
- Sugars  

Add

Figure 268. Nutrition configuration

Sections

Number of sections here will be applied to all items. You can add or remove a section with the button [Add] or the bin.

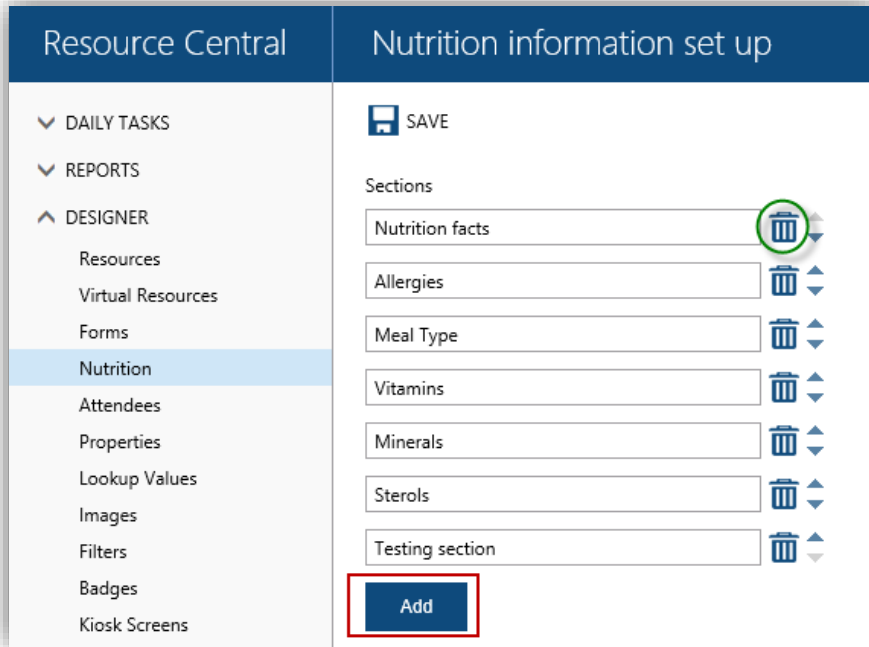

Figure 269. Configure nutrition information for all items

In the above figure, you can see that there are 7 nutrition sections, i.e., these sections will be available in **Nutrition Information** panel of an item.

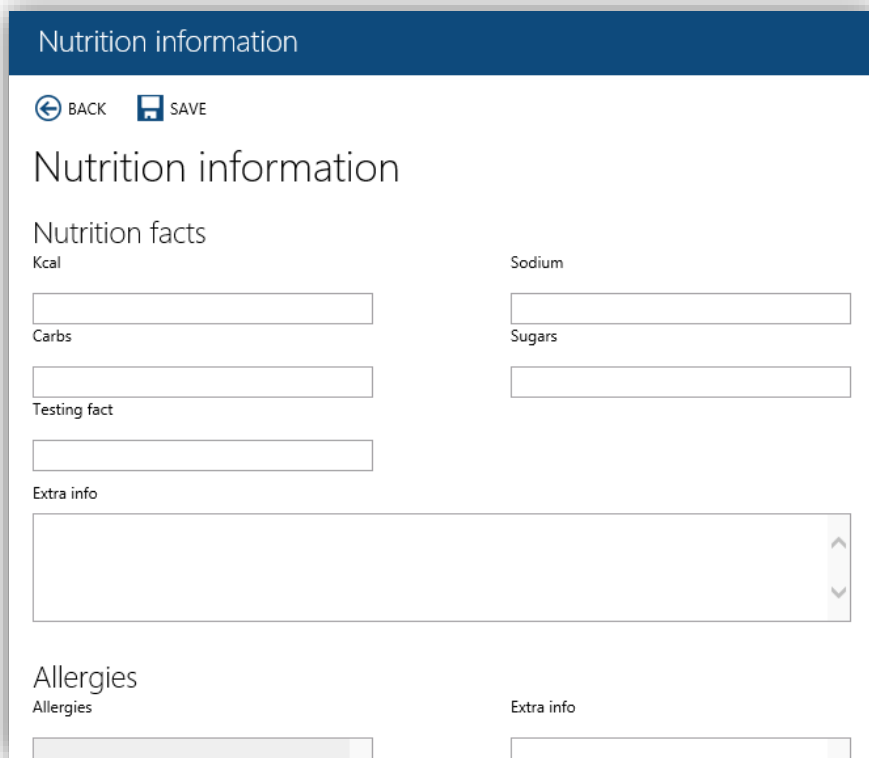
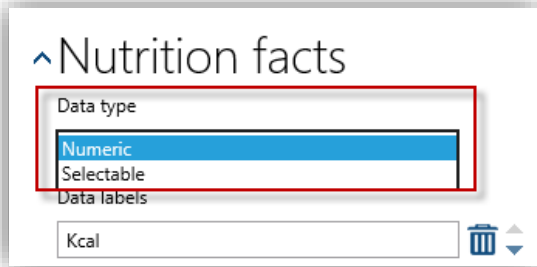

Figure 270. Nutrition information of an item

Data type

Data type helps you control how the nutrition information is filled in. There are 2 data types for you to select in each nutrition section:



- **Numeric:** The field is displayed as a text box, and you can enter a numeric value.

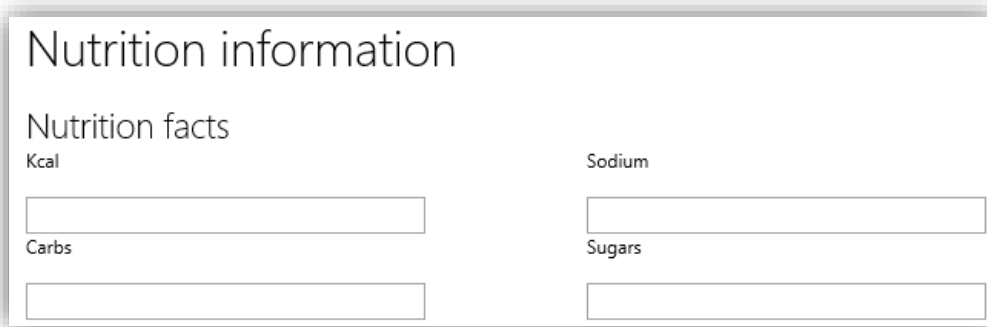

Figure 271. Datatype – Numeric

- **Selectable:** The field can be selected with a lookup button.

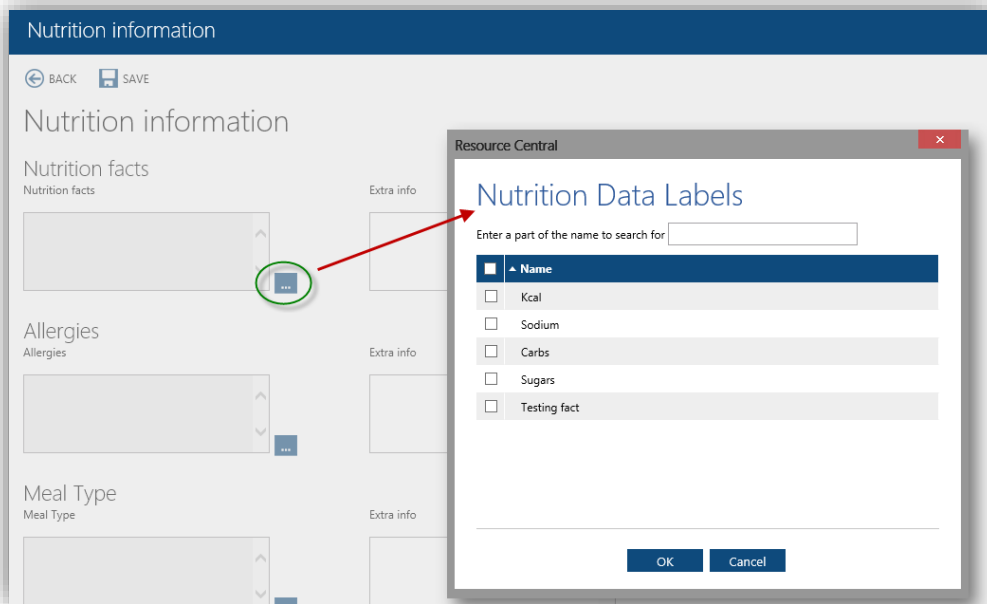

Figure 272. Data type – Selectable

It means that in the Nutrition information panel of an item, clicking the [...] lookup button will open a new window for you to select data labels.

Visitors

You can configure settings for Visitors with 3 following sections:

Caption and Customizable Fields

In this section you can configure visibility of the fields that can be used for visitors.

Required	Visibility	Sort order	Basic data
<input type="checkbox"/>	Kiosk + Order form + Visitor + My Meetings	31	<input type="checkbox"/>
<input type="checkbox"/>	Kiosk + Order form + Visitor + My Meetings	2	<input checked="" type="checkbox"/>
<input type="checkbox"/>	Kiosk + Order form + Visitor + My Meetings	1	<input checked="" type="checkbox"/>
<input type="checkbox"/>	Kiosk + Order form + Visitor + My Meetings	4	<input type="checkbox"/>
<input checked="" type="checkbox"/>	Kiosk + Order form + Visitor + My Meetings	5	<input checked="" type="checkbox"/>
<input type="checkbox"/>	Kiosk + Order form + Visitor + My Meetings	12	<input checked="" type="checkbox"/>
<input checked="" type="checkbox"/>	Kiosk + Order form + Visitor + My Meetings	3	<input checked="" type="checkbox"/>

Label	Caption	Required	Visibility	Sort order	Field type	Basic data
Field 1	Wifi access	<input type="checkbox"/>	Kiosk + Order form + Visitor + My Meetings	7	Text	<input checked="" type="checkbox"/>
Field 2	Address	<input type="checkbox"/>	Kiosk + Order form + Visitor + My Meetings	8	Text	<input checked="" type="checkbox"/>
Field 3	City	<input type="checkbox"/>	Kiosk + Order form + Visitor + My Meetings	9	Text	<input checked="" type="checkbox"/>
Field 4	Health & Safety induction completed	<input checked="" type="checkbox"/>	Visitor	10	Checkbox	<input checked="" type="checkbox"/>
Field 5	Reason for visit	<input checked="" type="checkbox"/>	Kiosk + Order form + Visitor + My Meetings	6	Text	<input checked="" type="checkbox"/>

Disregard required fields in Visitors module.

Figure 273. Visitors - Information and Customizable Fields

The visibility of **Required** column is controlled by the parameter **Visitor.EnableRequiredField**. When you check on a box in this column, the relevant field will be set as a required field.

In **Visibility** column, you can select where you want the relevant field to be displayed:

Figure 274. Visitor – Visibility

You can also add more fields and select where you want the added field to be visible in **Customizable Fields** section.

On the right-most side of each field is the **Basic data** option:

- If checked, its respective data as ‘basic data’ that is stored for later usage.
- If unchecked, its respective data will be stored on individual visit instead.

Finally, there is ‘**Disregard required fields in Visitors module**’ option. If checked, all fields that are set as required will be ignored in the Visitor module used by the receptionists.

Visitor types

In this section, you can add visitor types and assign them to specific locations.

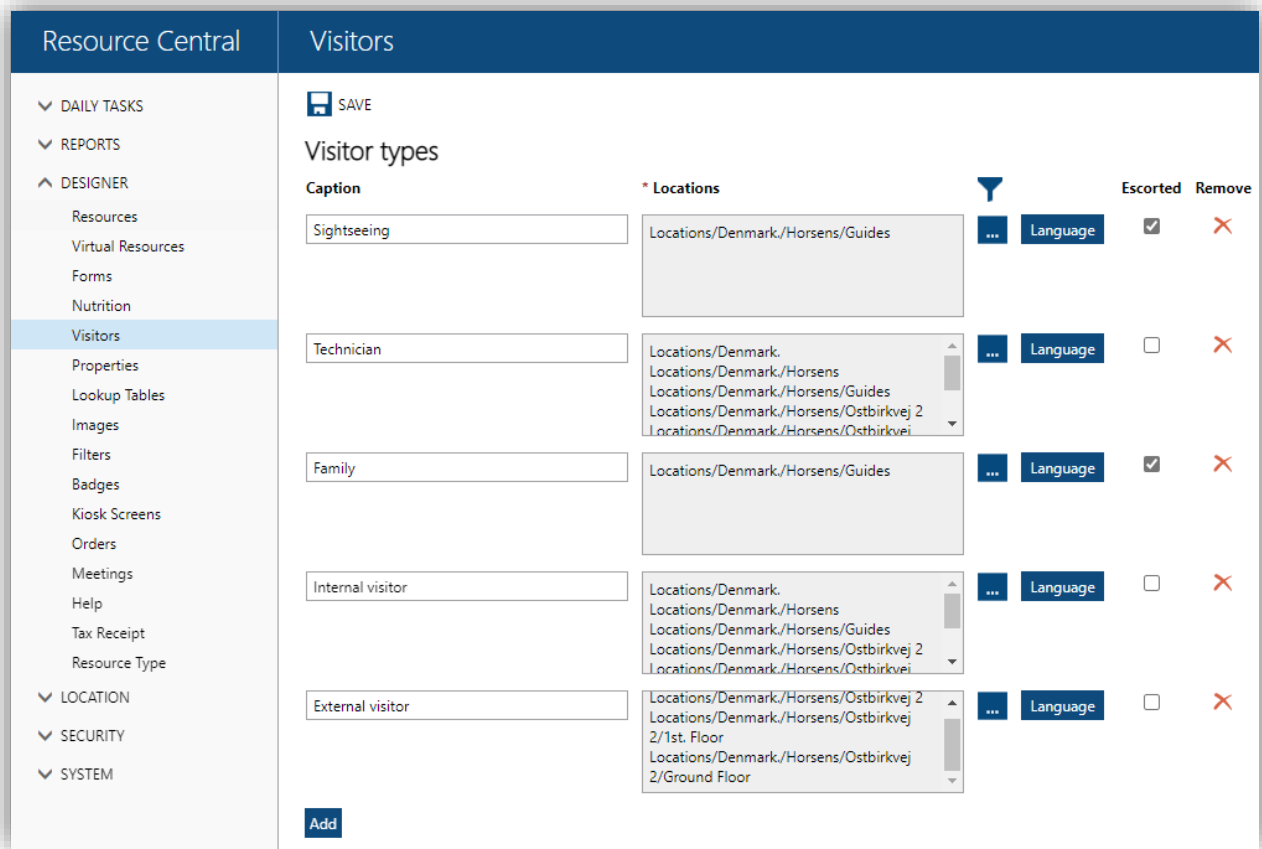

Figure 275. Visitor types

Fields	Description
Caption	The name of visitor type.
Locations	Select the locations that the visitor type is available in.
Language	Translation of visitor type's name in other languages.
Escorted	Check on this option will determine that visitors of this type will require escorts.
Remove	Click to delete the respective visitor type.

This section also includes other settings that affect Visitors in general.

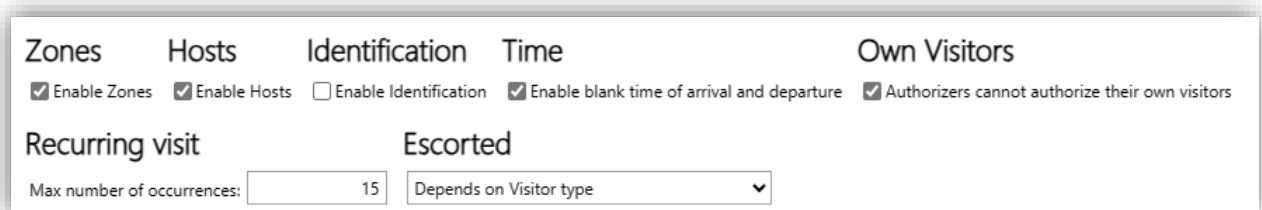
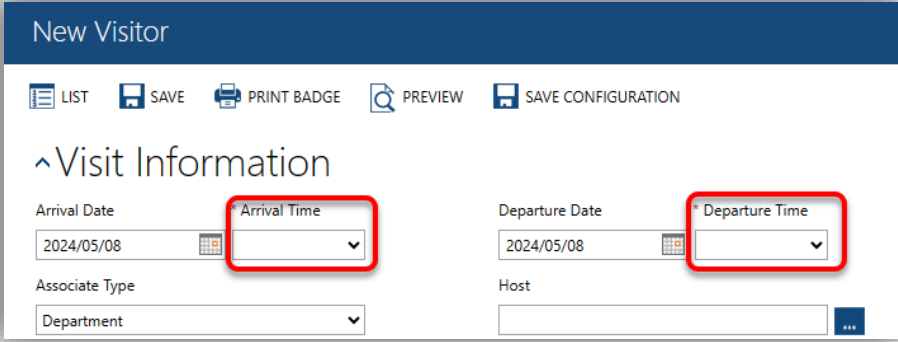

Figure 276. Visitor – general settings

Settings	Description
Recurring visits	Set the maximum number of recurring visits that can be created for every visitor. If the value is blank, visitors can have any number of recurring visits.
Zones	Enable/Disable Zone selection when registering new visitors on ResourceFinder or RC backend. This option also enables/disables ' Zones ' section in RC backend → Location and Zones selection under a Person Details .
Hosts	Enable/Disable Hosts selection when registering new visitors on ResourceFinder or RC backend.
Identification	Enable/Disable Identification section in RC backend → Daily Tasks → Visitors → Visitor Details .
Time	If this option is checked, the Arrival Time and Departure Time fields when adding new visitors are blank. 
Own Visitors	If this option is checked, Authorizers cannot authorize their own visitors.
Escorted	Choose between 5 Escorted options: <ul style="list-style-type: none"> • Escorted feature disabled: disable this feature entirely. The Escorted checkbox no longer appears in 'Visitor type' section. • Default value displayed is Escorted: when creating new visitors, they will be set as 'Escorted' by default. Selecting this option will overwrite all Escorted settings from 'Visitor type' section. • Default value displayed is Unescorted: when creating new visitors, they will be set as 'Unescorted' by default. Selecting this option will overwrite all Escorted settings from 'Visitor type' section. • Blank value: when creating new visitors, their 'Escorted' field will be set as blank. Selecting this option will overwrite all Escorted settings from 'Visitor type' section. • Depends on Visitor type: the Escorted option will be based on 'Visitor type' section.

When you finish configuration, click **[Save]** to finish.

In addition, you can enable the Visitor cleanup feature with the parameter **Visitor.Historical.Deletion.Enable**. When enabled, it will automatically delete visitor data that is older than the time specified by the parameter **Visitor.InfoRetention.Days**.

For more details on the Visitor cleanup feature, please refer to the 2 mentioned parameters in **RC Parameter Guide**.

Visitor Emergency Report

In this section, you can create templates to run as Emergency reports.

Name	Location		
Default location	Locations		
Vietnam	Hanoi		
USA	Texas		
Australia	Perth, Sydney, Resource Delegate, Australia		
Bruxelles (Belgium)	Bruxelles		
København	Danmark		

Add

Figure 277. Emergency report templates

Default Location template is always made for you. You can add new templates as you wish by clicking [Add] and a pop-up window will appear as follows:

Resource Central

SAVE SAVE CONFIGURATION

Report content

* Name

* Location

Group by location

Email (Each address per one line)

* Columns Setting

Ascending
 None
 None
 None
 None
 None

Add a column

Figure 278. Add templates

Fields	Description
Name	The name of report template
Location	Select the location for the report template
Group by location	If this box is checked, the report result will be displayed for each location
Email	The Emails to which the reports are sent NOTE: Each email is written in one line
Column Setting	The fields which will be displayed in the report result. Click [Add a column] to add a field and click X to delete a field. Select Ascending/Descending if you want to sort the result in a specific way

Toolbar Buttons	Description
SAVE	Save the template
SAVE CONFIGURATION	Save the Columns Setting part for future new templates The Column Setting section will be saved so that the next time the user adds a new template, this section will be pre-populated with those saved columns.

Click  to edit a template. Then, click **[Save]** to finish.

To delete a template, click  and a confirmation box as follows will appear:

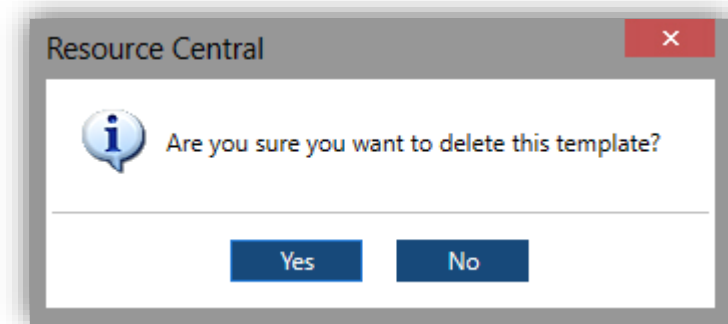

Figure 279. Deleting template confirmation

Click **[Yes]** to confirm, **[No]** to cancel the deletion.

NOTE: For Default template:

- You cannot edit its Location.
- You cannot delete the default template.

Properties

Properties are used for **extending** the order forms with new fields:

Text	No.	Required	Use Status
WiFi access code	RC_Wifi_Access	No	No
Whiteboard	RC_Whiteboard	No	Yes
WBS Element	WBSElement	No	No
Videokonference	Bestillinger.VideoConference	No	No
Use Meeting Door Sign	ModuleXUseMeetingDoorSign	No	No
txt5	field8	No	No
txt4	field7	No	No
txt3	field6	No	No
txt2	field5	No	No
txt1	field	No	No
Test.12345,54321	Test.12345,54321	No	No
Test	Test1	No	No
Tablets	EVENT_AV_Tablets	No	No
Tables	EVENT_Table	No	No

Figure 280. List of Properties

Toolbar Buttons	Description
NEW	Create a New property
DELETE	Delete a selected property
SET USE STATUS	Set all selected properties as Yes or No <ul style="list-style-type: none"> If Yes: the property can now be set with a status in the Order. Also, it will affect Order status calculation. If No: the property cannot be set with a status, and it does not affect Order status.
PRINT	Print all the properties on the screen

Clicking one of the **properties** will show details about it.

NOTE: There are thirteen (13) Properties which are created as part of the system. All these Properties can be modified by the user, but they **cannot be deleted** from the system.

Twelve of these properties are related to the **Resource Central Admin → Daily Tasks → Visitors** section. These properties have their name starting with “VR_” word. All these properties will be available to be used in the Badge designing for Visitors at **Resource Central Admin → Designer → Badges → Edit Badge**.

Property details

Viewing a given property, you can **edit** and **save** it or select **[Roles]** to relate roles.

Figure 281. Details of a Property

Field	Description
Number	Name of the property. This value can be used in your customized order form. It should be unique .
Text	The " friendly " name of the property. This value is used when you insert a field on a sub form and is also used in the order confirmation email
Tip	Value of this field is content of the tooltip which will appear when user rolls the mouse over the field associated with this property on the Order Form
Description	A short description. Max 255 characters
Sent to	Controls who will receive this information: <ul style="list-style-type: none"> • All: Property will be visible in the order form to all persons related to the order. • Specific role: Property will be visible in order form only to roles associated with the property. • None: Property will not be visible to anyone.



Sort Order	Sort order can hold any alphanumeric values and can be used for sorting the properties
Locked	If you select " Yes ", then the responsible role (s) of this property will not be allowed to make any changes to the value of this property, as this property will appear as Disabled at the corresponding interfaces
Use status	Choose either Yes or No <ul style="list-style-type: none"> If Yes: the property can now be set with a status in the Order. Also, it will affect Order status calculation. If No: the property cannot be set with a status, and it does not affect Order status. (Refer to Service Provider handling service orders for further details on this option and its configuration)
Required	If you select " Yes ", you can specify a message which will be displayed to the user when the property is not filled out on the order form
Length	Maximum number of characters that can be entered as value of this property
Format type	Select a format for value of this property. <ul style="list-style-type: none"> None: Value with all format types is accepted. Text: Entered value must be text (e.g., 'car', 'bike') Date: Entered value must be date format (e.g., 15/04/2020) Number: Entered value must be digits (e.g., 25464) E-mail: Entered value must be email address (e.g., johndoe@hotmail.com) Special: Entered value must be a sequence of characters that forms a search pattern following Regular expression definition (e.g., x{5}-g{6})

Toolbar Buttons	Description
LIST	Displays the list of all properties
SAVE	Saves the information in the input fields
ROLES	Displays the list of roles associated with the property
ASSOCIATED FORMS	Open list of Order Forms that use this property
ASSIGNMENTS	Open list of Persons who are assigned with this property

Property details: Roles

The **Roles view** shows you which roles are related to the selected property. Use [**Add Role**] to select from roles to add. Mark the roles with a **checkmark** next to the role and select [**Delete**] to delete the relation or click [**Property**] to return to the property view.

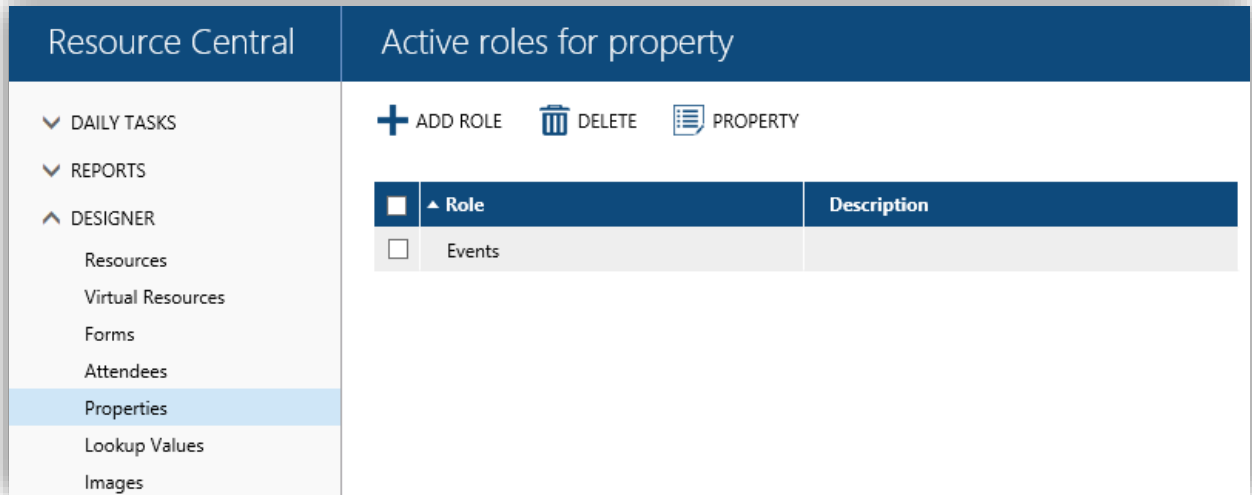

Figure 282. List of Roles for a Property

When a role is added to a property, it will be displayed in the **Active roles for property** list.

A property can have many roles.

For example: Property A has 3 roles: SDK, Info and Host.

Property details: Associated Forms

When clicking [**Associated Forms**] button, a pop-up window shows up with a list of forms in which the property is used. If it is not used in any form, the following message appears:

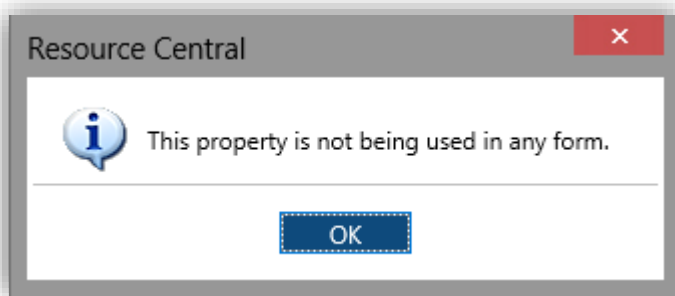

Figure 283. Message: Property not used by any form.

Lookup values

This screen you can define the **lookup values** to be used in a form:

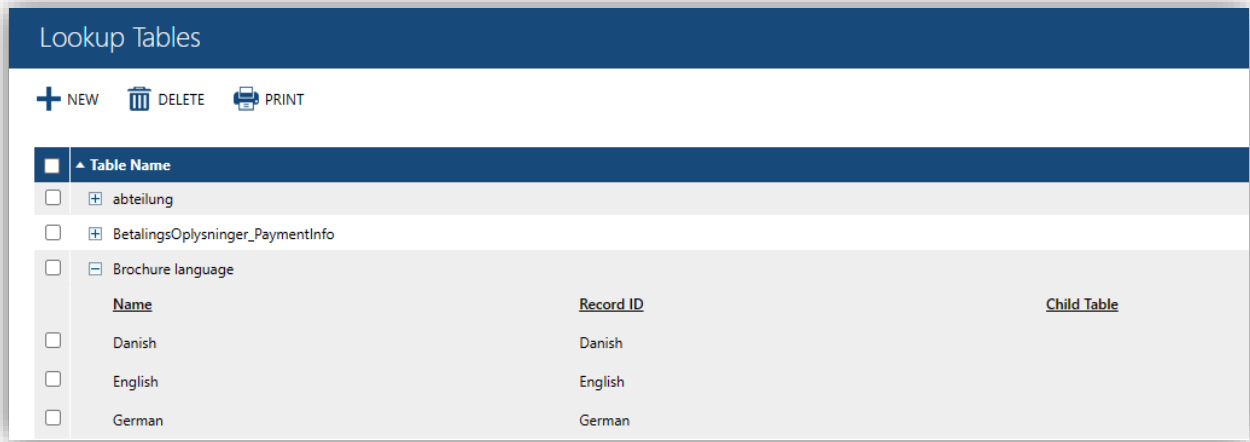

Figure 284. List of Lookup Values

Toolbar Buttons	Description
NEW	Create a New lookup value
DELETE	Delete a selected lookup value
PRINT	Print the table name list on the screen

Clicking one of the lookup values will show details about it.

Lookup value details

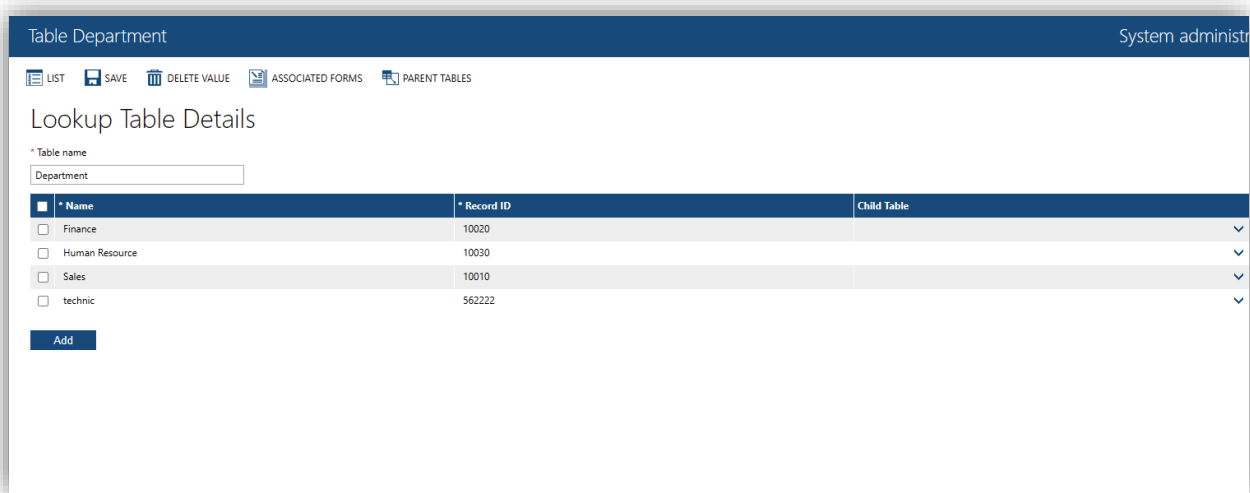

Figure 285. Details of a Lookup Value

Field	Description
Table Name	Value used for grouping lookup values together, typical values are PROJECT, COMPANY, EMPLOYEE etc.
Name	The name of the record
Record ID	The ID of the record

Email	Email address – A text box where you can edit an email address. This field is controlled by the parameter named “ LookupValueMail ”. For more details about this parameter, refer to <i>Resource Central Parameter Guide</i> .
Child table	Add a child table

Toolbar Buttons	Description
SAVE	Saves the information in the input fields
LIST	Displays the list of all the lookup values
ASSOCIATED FORMS	Click on this to see which form this lookup table is assigned to.
PARENT TABLES	Click on this to see the parent tables of this lookup table.

Images

This section is used for **uploading images** to Resource Central. These images can be used in **Forms** and **Resources**.

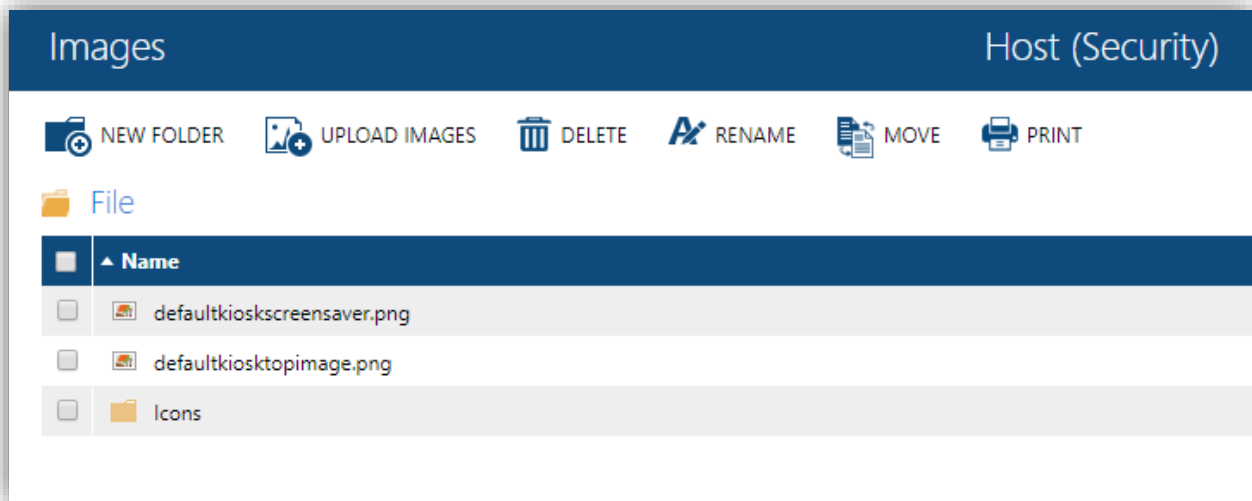

Figure 286. List of Images

Toolbar Buttons	Description
NEW FOLDER	Create new folder/sub-folder.
UPLOAD IMAGES	Upload a New Image
DELETE	Delete a selected Image
RENAME	Select an image/folder to rename
MOVE	Select an image/folder that you want to move to another place
PRINT	Print the screen

Clicking one of the image records will **show details** about it.

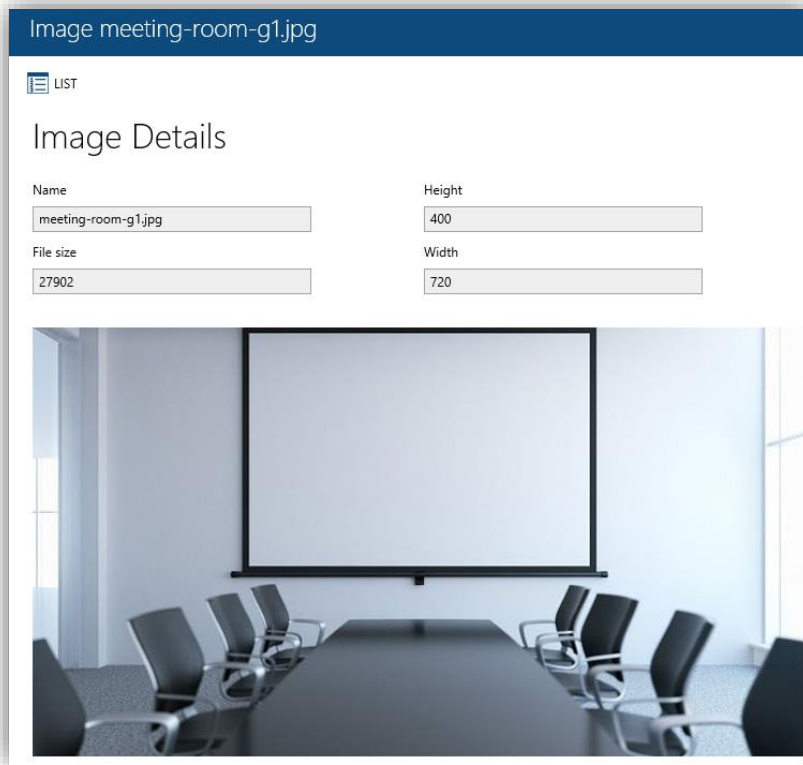

Figure 287. Details of an Image

Upload a new image

You can **Upload New Images** in the system by clicking **[New]** at the **toolbar** which will **display** the control for **uploading new images** in the system.

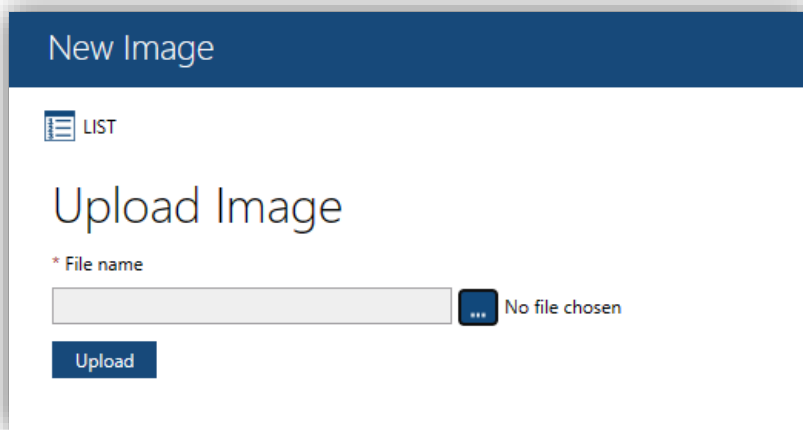

Figure 288. New Image Upload

Field	Description
File name	You can browse the path of a file in your system to be uploaded

Buttons	Description
Upload	It will upload the selected file

Create a new folder/sub-folder

Click on **[New button]** to create a new folder (or a sub-folder inside an existing folder), the following panel shows up:

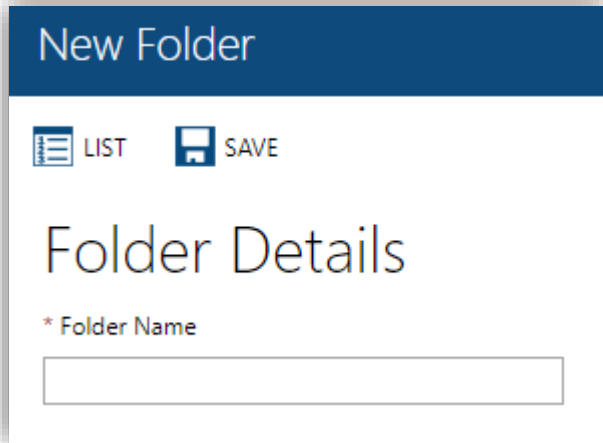

Figure 289. Create a new folder

Fill in the folder name and click **[Save]** to finish.

NOTE: When you move a used image to another folder, the path to this image is automatically changed and you do not have to re-select this image in places where it is used.

Filters

Filters are used for **configuring ResourceFinder** searches and are shown in the Filters section in the ResourceFinder window.

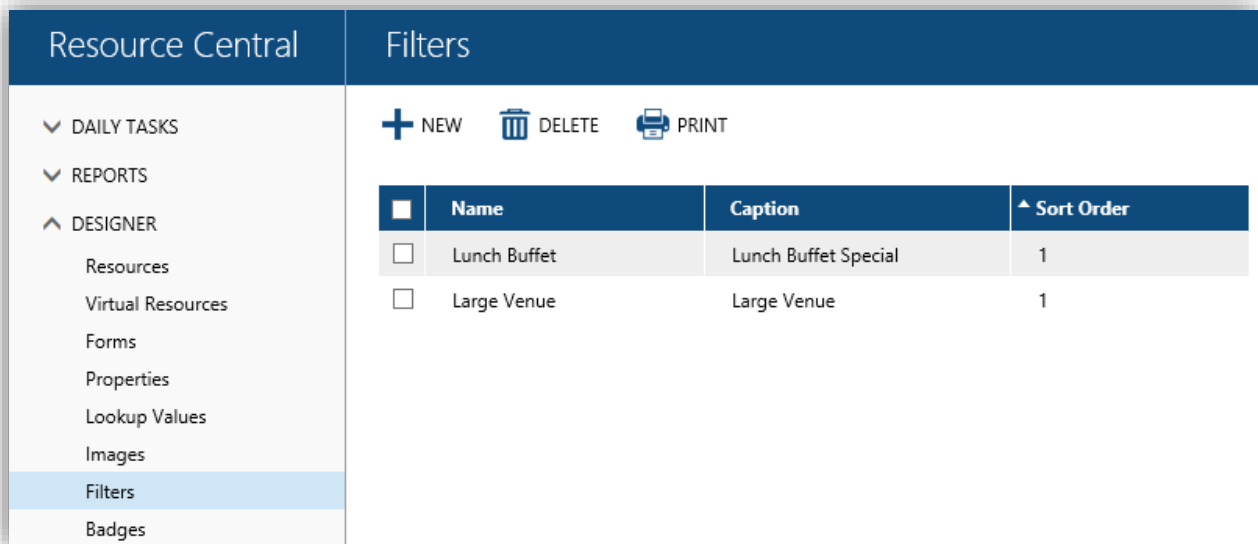

Figure 290. List of Filters

Toolbar Buttons	Description
NEW	Create a New filter
DELETE	Delete a selected filter
PRINT	Print the screen

Clicking one of the filter records will **show details** about it.

The filter records will be shown to you when you click the **FILTER** button in the **ResourceFinder Application**, as shown below:

The screenshot displays the ResourceFinder application interface. On the left, there is a sidebar with sections for 'Date and Time', 'Locations', 'Categories', 'Favorites', and 'Search and Filter'. The 'Date and Time' section includes fields for 'Start time' (12-08-2016, 14:00) and 'End time' (12-08-2016, 14:30), along with a calendar for August 2016. The 'Search and Filter' section has a search bar and fields for 'Resource' and 'Capacity' (set to 'More/ Equal'). A 'Filter' dialog box is open, showing two filter options: 'Lunch Buffet Special' (checked) and 'Large Venue' (unchecked). 'Run' and 'Clear' buttons are at the bottom of the filter dialog. On the right, the 'Resource Overview' table is visible, with columns for 'RESOURCE', 'CAPACITY', and '10:00'. Two rows are highlighted with a red box: 'Meeting Room 001' with a capacity of 5, and 'Meeting Room 002' with a capacity of 10.

RESOURCE	▲ CAPACITY	10:00
<input type="checkbox"/> Meeting Room 001	5	
<input type="checkbox"/> Meeting Room 002	10	

Figure 291. Filters in the ResourceFinder

NOTE: When a filter is run in ResourceFinder, the returned result shows all resources located in the selected location/category and its child level.

Filter details

The screenshot shows a web form titled "Filter Lunch Buffet". At the top left, there are two buttons: "LIST" (with a list icon) and "SAVE" (with a save icon). The main heading is "Filter Details".

The form contains the following fields and controls:

- * Name:** A text input field containing "Lunch Buffet" with a clear (X) button.
- * Tree position:** A dropdown menu currently showing "Categories" and a menu icon (three dots).
- * Caption:** A text input field containing "Lunch Buffet Special".
- Sort order:** A text input field containing "1".
- Description:** A large text area for entering a description.
- Frontpage:** Radio buttons for "Yes" (selected) and "No".

Figure 292. Details of a Filter

Field	Description
Name	A code for identifying the record
Caption	The value displayed in the ResourceFinder Application when FILTER button is clicked
Description	A short description. Max 255 characters
Frontpage	Select yes if you want to show the filter in ResourceFinder Filter section.
Tree position	The place in the " tree " where this search starts
Sort Order	Sort order can hold any alphanumeric values and are used for sorting search options on the front page of ResourceFinder

Toolbar Buttons	Description
SAVE	Saves the information in the input fields
LIST	Displays the list of all the filters

Badges

In order to facilitate you in the Visitor Registration process, Resource Central allows you to define your **own badges**, or you can also **customize** the already created badges. Badges can only contain the specific Visitor Related Properties.

There 5 system badges that are created by default as part of the system. One of them will be set as **Default** (Is Default = 1). You can make any of the defined badges as Default.

Note that the system will not allow you to delete Default badge and System badges.

Each Badge can be designated to specific Locations. This means if you select a badge type for a visitor, you can only select among the badges designated to that visitor's location only.

	Name	Is Default	Location
<input type="checkbox"/>	0 Dubai	0	Locations\Dubai
<input type="checkbox"/>	0 Dubai v1	0	Locations\Dubai\Dubai 1 all blank
<input type="checkbox"/>	0 Dubai v2	0	Locations\Dubai\Dubai 2 all blank ex
<input type="checkbox"/>	0 Private	0	Locations\Private
<input type="checkbox"/>	0.1 Dubai v2	0	Locations\Dubai\Dubai 2 all blank ex
	1 Amsterdam	1	Locations\Netherlands\Amsterdam
<input type="checkbox"/>	1 Draft 24	0	
<input checked="" type="checkbox"/>	1 Dubai	1	Locations\Dubai
	1 Locations/Private/Hamburg H...	1	Locations\Private\Hamburg Hamburg Hamburg Hamburg\Building 16
	1 Locations/Private/Hamburg H...	1	Locations\Private\Hamburg Hamburg Hamburg Hamburg\Building 8
<input checked="" type="checkbox"/>	Badge1	0	Locations
<input checked="" type="checkbox"/>	Badge2	0	Locations
<input checked="" type="checkbox"/>	Badge3	0	Locations
<input checked="" type="checkbox"/>	Badge4	1	Locations\Private\Berlin
<input checked="" type="checkbox"/>	France 1	1	Locations\France
<input type="checkbox"/>	New York Badge	0	Locations\USA\New York
<input type="checkbox"/>	Paris 0	0	Locations\France\Paris

Figure 293. List of Badges

Toolbar Buttons	Description
NEW	Create a New Badge
DELETE	Delete a selected user-defined Badge
PRINT	Print the screen

Clicking on a badge will show its details, as shown in figure below:

The screenshot shows the 'Badge Details' form with the following fields and values:

- Name:** New York Badge
- Width:** 3
- Height:** 1.5
- Unit:** in
- Is Default:** No
- Locations:** Locations\USA\New York, Locations\USA\New York\Building 1, Locations\USA\New York\Building 2

The badge preview includes a silhouette, the following text, and a barcode:

```
Title: xxxxxxxx
Name: xxxxxxxx
Company: xxxxxxxx
Email: xxxxxxxx
ID Document Type: xxxxxxxx
ID Number: xxxxxxxx
```

Barcode: 000000000001

Figure 294. Details of a Badge

Field	Description
Name	Name of the Badge
Width	Allowed width for the badge
Height	Allowed height for the badge
Unit	Select Unit for the Badge width and height. Select 'in' or 'cm' (inches or centimeters)
Is Default	Select Yes to make the current Badge as Default
Locations	Select Locations where the Badge will be applicable to. Only visitors who will arrive at the same locations can be given with this Badge.

Toolbar Buttons	Description
SAVE	Saves all the changes in the Input fields

LIST	Displays the list of Badges
EDIT BADGE	Opens the badge in the Badge Editor

Badge: Edit Badge

Clicking the **[Edit Badge]** at the toolbar opens the current badge in an HTML editor. Within the 'Badge Editor' screen, you are able to configure the layout of the badge by adding different visitor or visit data properties to the badge as well as arrange and adjust them using the HTML editor:

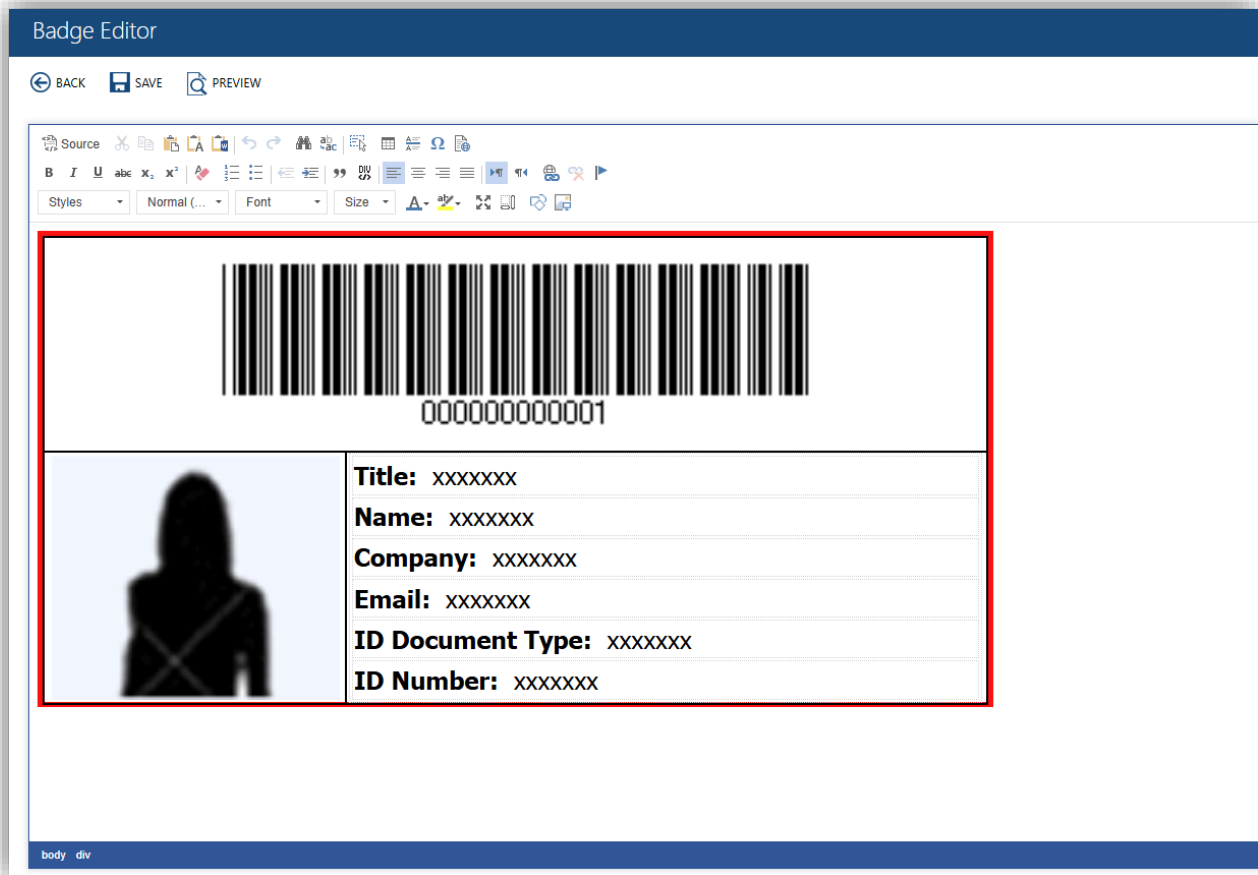

Figure 295. Badge in the Badge Editor

NOTE: There is a red rectangle with the dimensions (Width and Height) set on the 'Badge Details' screen. This red rectangle will define the boundaries of your badge configuration and you should not let your badge extend beyond these boundaries as it can exceed the paper boundaries of the printed badge.

Click the  icon for inserting properties on this form.

When you **insert** property fields into the form, be sure **not to insert** the same properties **twice**.

NOTE: The HTML for the badge should be correct. The values of the properties will not be populated correctly in the badge preview if there are any syntax problems in HTML.

Badge: Inserting properties

Selecting **[Insert Property]** will make an "insert input field dialog" pop up. You can select a property from the list of defined visitor specific properties as shown in figure below:

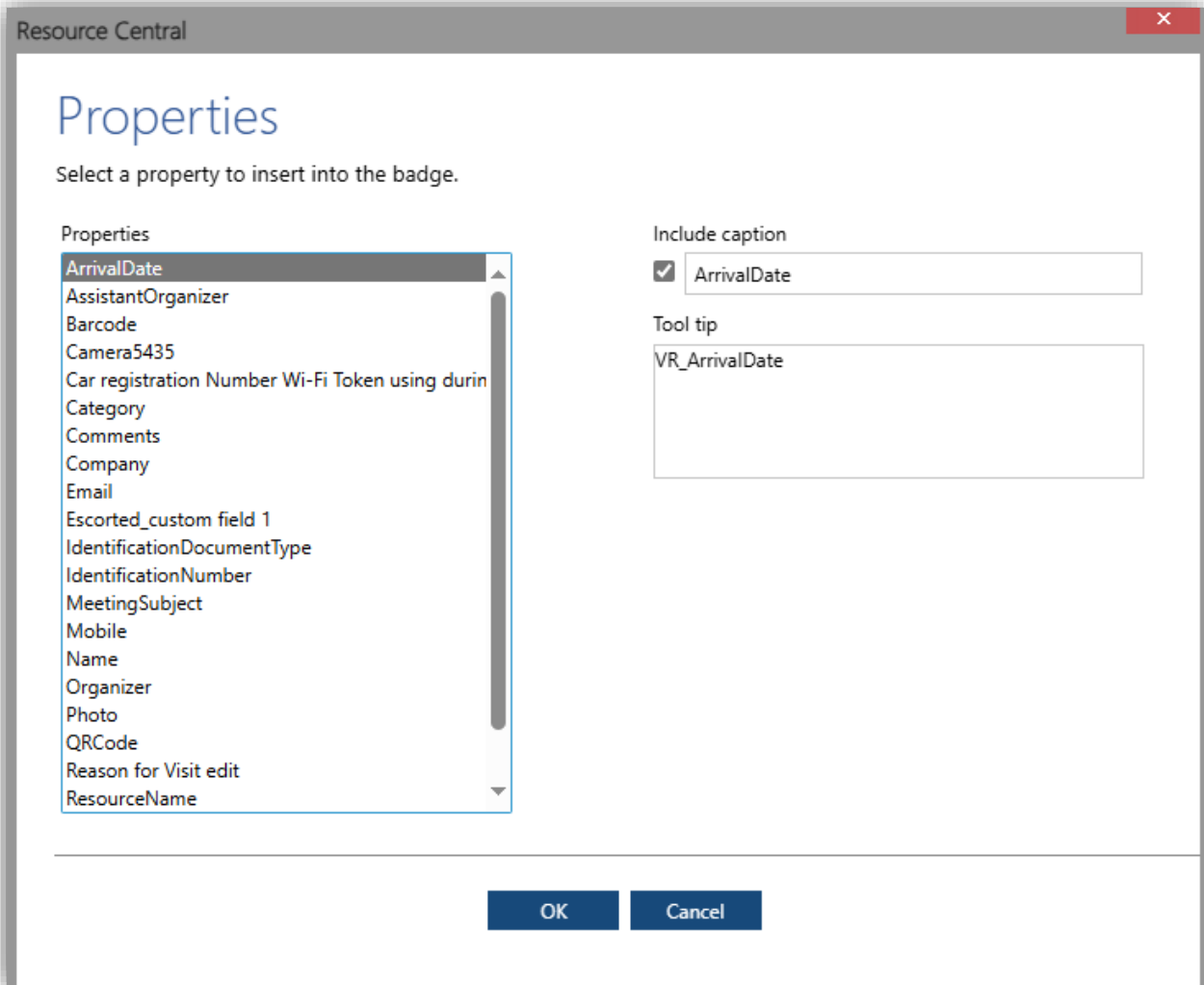

Figure 296. Insert Property Dialog for a Badge

CustomVisitorfield1-5 texts are taken from **Designer → Visitors** section and will be displayed according to your custom configuration of their names.

Field	Description
Properties	All the defined properties in the application
Include caption	A checkbox to include the caption on the form
Group	Group of the property
Tool tip	Enter tool tip which will be shown when you roll the mouse over that property field in the form
Field type	Select the type of control for the selected property
Format	Select the length and the format type for the properties (the format type can be Text/Date/Number/Email/Special)
Dependency	Decide whether fields related to this property are required or not to be filled in on the form

Click **[OK]** to add. Then, use the features on the toolbar button to arrange and adjust the properties. Click **[SAVE]** to finish editing.

Kiosk Screens

Refer to *RC Kiosk Administrator Guide* for more details about this part.

Orders

In this section you can configure notification color for orders, which can be seen in **Daily Tasks/Orders**. Also, the order of the sections in order form can be configured in this section.

The screenshot shows the 'Order Configuration' interface. At the top, there is a 'SAVE' button. Below it, three notification colors are configured: 'Arranged' with hex code #55abe5 (blue), 'Locked' with hex code #b9c0cb (grey), and 'Cancelled/ Declined' with hex code #ce4b28 (red). Under 'Color display', the option 'The entire row' is selected. The 'Active legends' section shows a row of color-coded boxes for 'New' (yellow), 'Changed' (orange), 'Confirmed' (green), 'Transferred' (red), 'Arranged' (blue), 'Locked' (grey), and 'Cancelled/ Declined' (red). The 'Order form sorting' section lists sections with their sorting order: Old order info (1), Reservation info (2), Recurring dates (3), Catering services (5), Visitors (4), and Extra services (6). The 'ResourceFinder Messages' section has a sub-section 'Moving meetings with orders across deadlines' with a text area and a 'Language' button.

Figure 297. Notification Color configuration

Click on the color next to each label to select the color of your preference. This will be applied when you navigate to Daily **Tasks/Orders**.

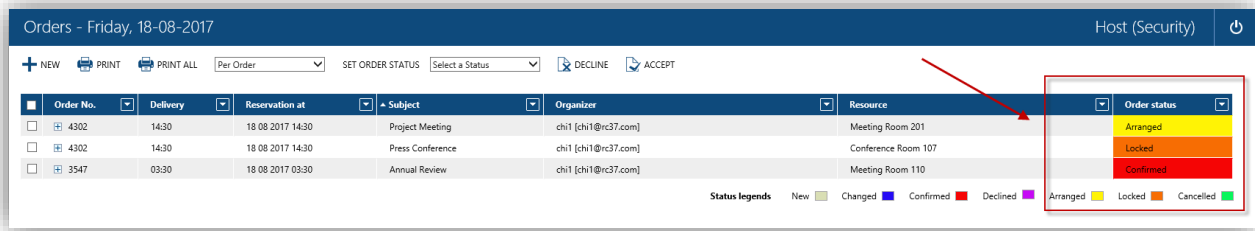

Figure 298. Daily Tasks - Orders

The **Order form sorting** section is where you can set the order of the sections in the order form.

Each heading is established with a number which indicates its position in the order form, ranging from 1 (there are 7 sections at most in the order form, so the maximum number is 7, provided that all sections are enabled). The heading with number '1' will be placed on top, and the heading with the maximum number will be at the bottom of the order form.

In **ResourceFinder Messages**, you can compose a message to be displayed at ResourceFinder (in COM Add-in or Outlook Add-in) or ResourceFinder mini (in Booking Manager) when meeting time is moved to after deadline of the order.

External Order

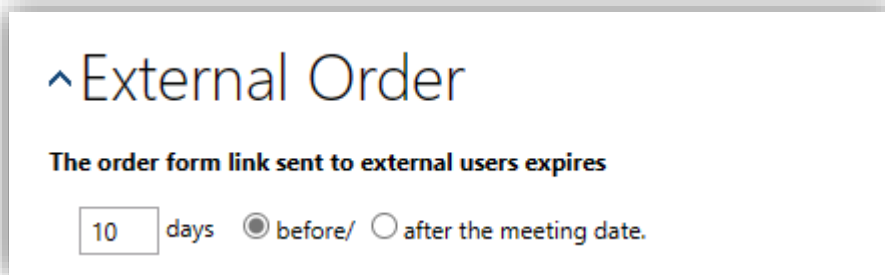

Figure 299. External Order configuration

The External Order configuration is used with the **External User** feature, which determines the time when the order form link for the external users / organizers expires.

For more details on this configuration and the External Users in general, please refer to **External Users Configuration Guide**.

Warnings on deliveries

Figure 300. Orders – Warnings on deliveries

This section allows you to customize a warning message if the delivery of the order is within the specified period. The customizable fields include:

Field	Description
Locations	Select locations that will apply the warning message.
Delivery time from/to	Specify the time period that will applies the warning message if the deliveries are sent .
Warning Message	<p>Enter the warning message.</p> <p>You can also click [Language] to enter translation messages to other languages.</p> <p>To add more warning messages to the same Locations you have selected, click [+] under <i>Remove</i> text.</p> <p>To delete the message, click .</p>

If you want to add new warning messages for different locations, click [**Add**].

When clicking [**Save**], these messages will appear on the Order form if the order’s delivery time is within the time periods specified above. E.g.:

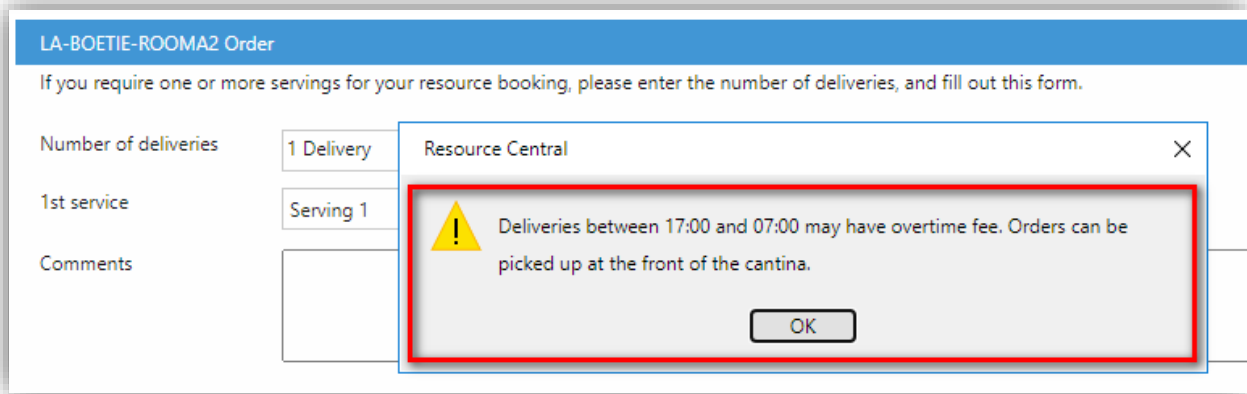

Figure 301. Delivery warning on the Order form

The same message also appears on the New reservation email sent to the organizer, e.g.:

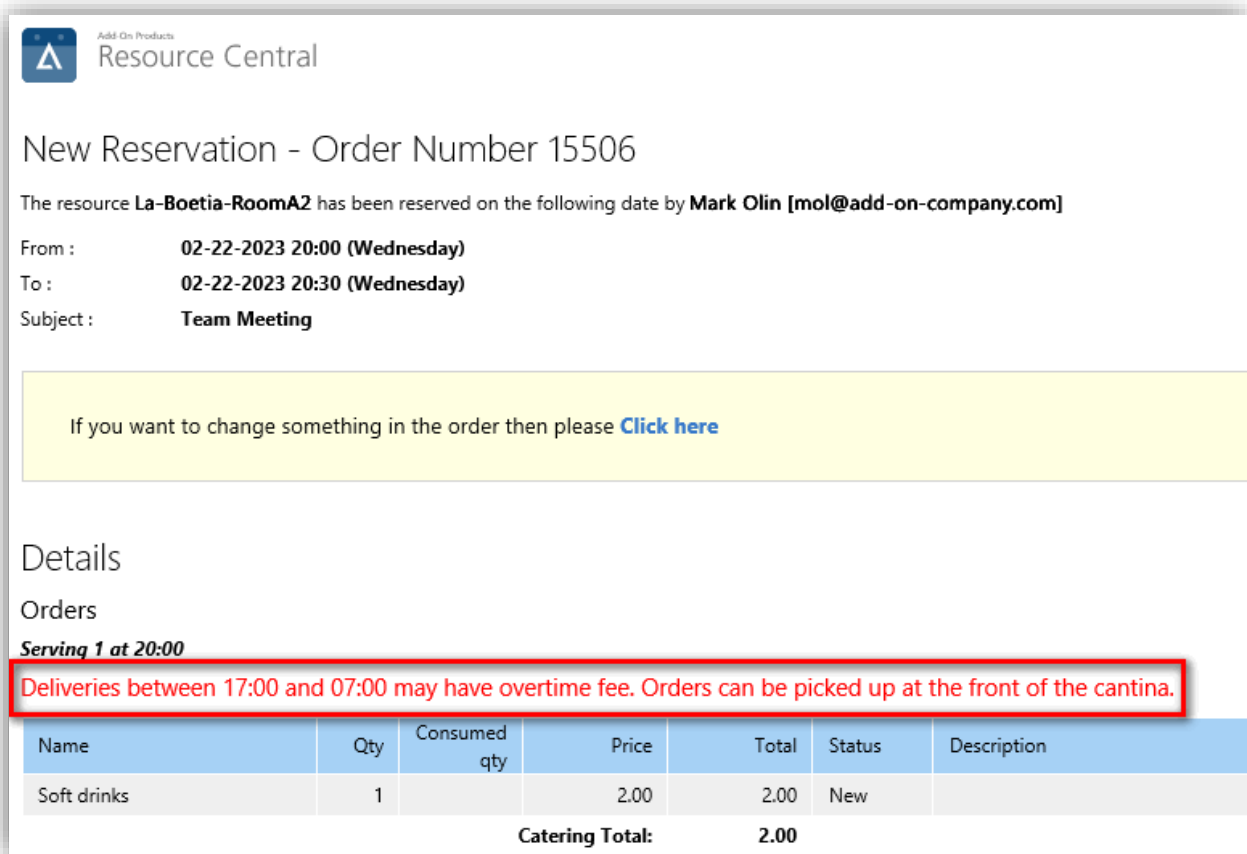

Figure 302. Delivery warning on the New reservation email

Quantity threshold messages

Figure 303. Quantity threshold messages

This section allows you to edit the display messages on the order form and 'New Order' & 'Changed Order' emails. By default, you can customize messages for all locations, specifically:

- **Message for order form:** This message appears when the organizers set an item's quantity that reaches its specified quantity threshold (refer to [Item details](#)) to let the organizers know that their order is now subjected to organization specific rules due to the exceeded quantity threshold. E.g.:

Name	Price	Qty	Quota
1	1220.00	Min. Qty: 5	
Café	3.00	10	37
Green Apple	20.00		780
Hung Item			491
HuyDT01			98
Mineral water			99
Soft drinks			999999966
trang item3			
Trang menu			

Figure 304. Example of the message for order form

You can also check [**Disable**] for *'Message for order form'* which will disable the message box above if e.g. it is only the service provider that should be made aware of the order quantity exceeding the threshold.

- **Message for 'New Order' and 'Changed Order' emails:** This message appears on the *'New Order'* and *'Changed Order'* emails. E.g.:

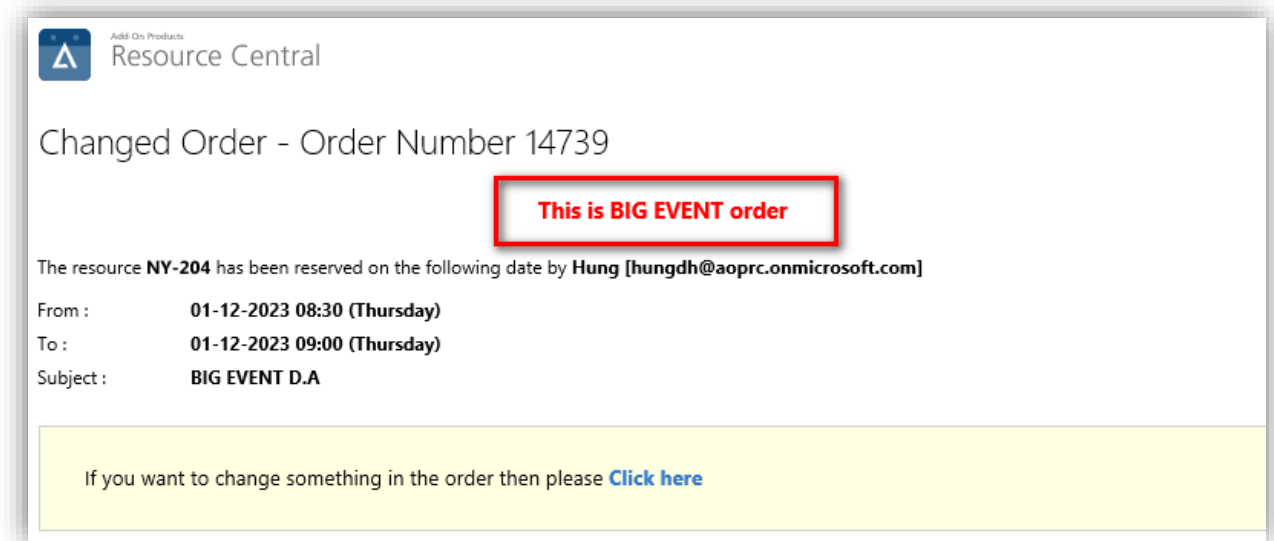

Figure 305. Example of message on Changed Order email

When you click [**Save**], the entered message will be applied to all orders that will be booked in every resource.

By default, the option [**Flag these orders in the Order overview**] is checked, which will mark the items that reaches their quantity threshold on the order overview for service providers and Orders list in RC backend. E.g.:

You can change the parts of the order for which you are responsible. A new order confirmation will be sent to the organizer and other persons concerned.

^ Detailed information about your reservation

^ Order details

Feedback

Serving 1 at 15:30

Name	Qty	Consumed Qty	Quota	Selling price	Sum	Status	Description
Café	2		40	3,00	6,00	New	
Green Apple	102		870	20,00	2040,00	Arranged	
Soft drinks	5		74	2,00	10,00	New	
Total					2056,00		

Add

Order - 14739

LIST PRINT UPDATE UPDATE AND SEND EMAIL RESOURCE LOCATION SEND TAX RECEIPT VIEW LATEST TAX RECEIPT VIEW TAX RECEIPT HISTORY

Project M... John Daniel

^ Order details

If you require one or more servings for your resource booking, please enter the number of deliveries, and fill out this form.

Number of deliveries: 1 Delivery

1st service: Serving 1 10:30

Comments

Serving 1 at 10:30

Name	Qty	Consumed ...	Quota	Sales price	Sum	Status	Description
Café	2		40	3,00	6,00	New	
Green Apple	102		870	20,00	2040,00	Changed	
Soft drinks	5		74	2,00	10,00	New	
Total					2056,00		

Figure 306. Marked item on order overview and RC backend → Orders list

Meetings

In this section you can configure color labels for meetings, which can be seen in **Booking Manager and COM Add-in**. With Meeting Labels, you can divide your meetings into different types, e.g., internal/external meetings, with a visual color marking. That brings about a quick overview and, for example, the booking manager can easily determine whether a meeting can be moved/rescheduled.

Figure 307. Designer/Meetings

Field	Description
Use meeting labels	Select Yes to enable meeting label function
Color in Booking Manager list	Decide how the labels will be applied to meetings (in Booking Manager)
Meeting label caption	Set up the name for meeting label icon to be displayed in ResourceFinder
Force organizer to select meeting label	If Yes is selected, organizer will be asked to select meeting label in ResourceFinder
Add	Click this button to add a new meeting label

After setting this up, you can see how it works in ResourceFinder and Booking Manager.

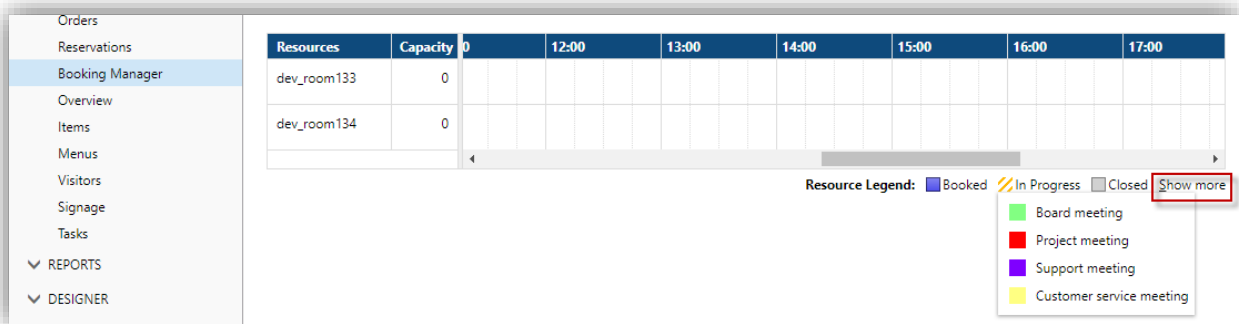
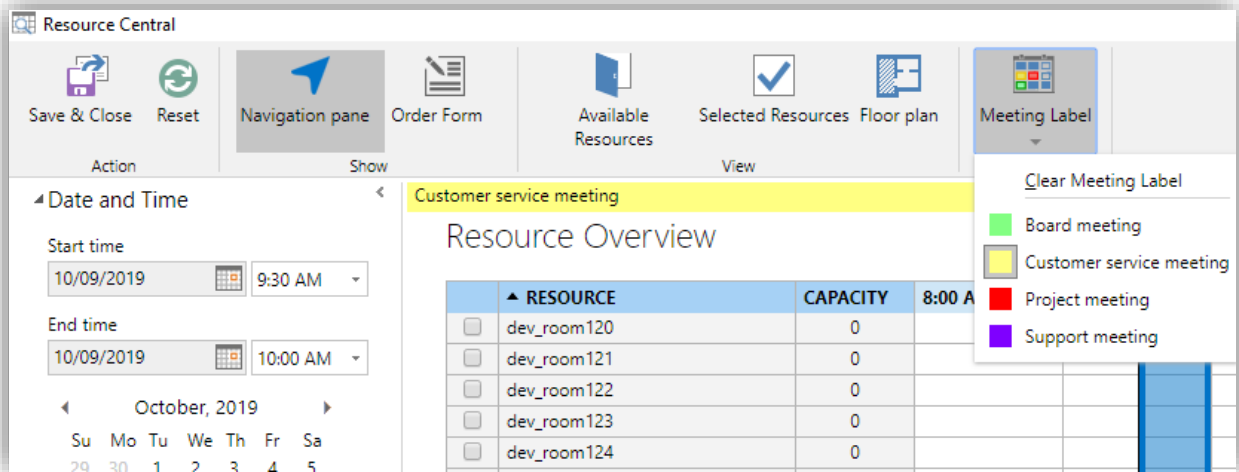

Figure 308. Color coding in ResourceFinder and Booking Manager

Additionally, you can see this in the Order form in ResourceFinder:

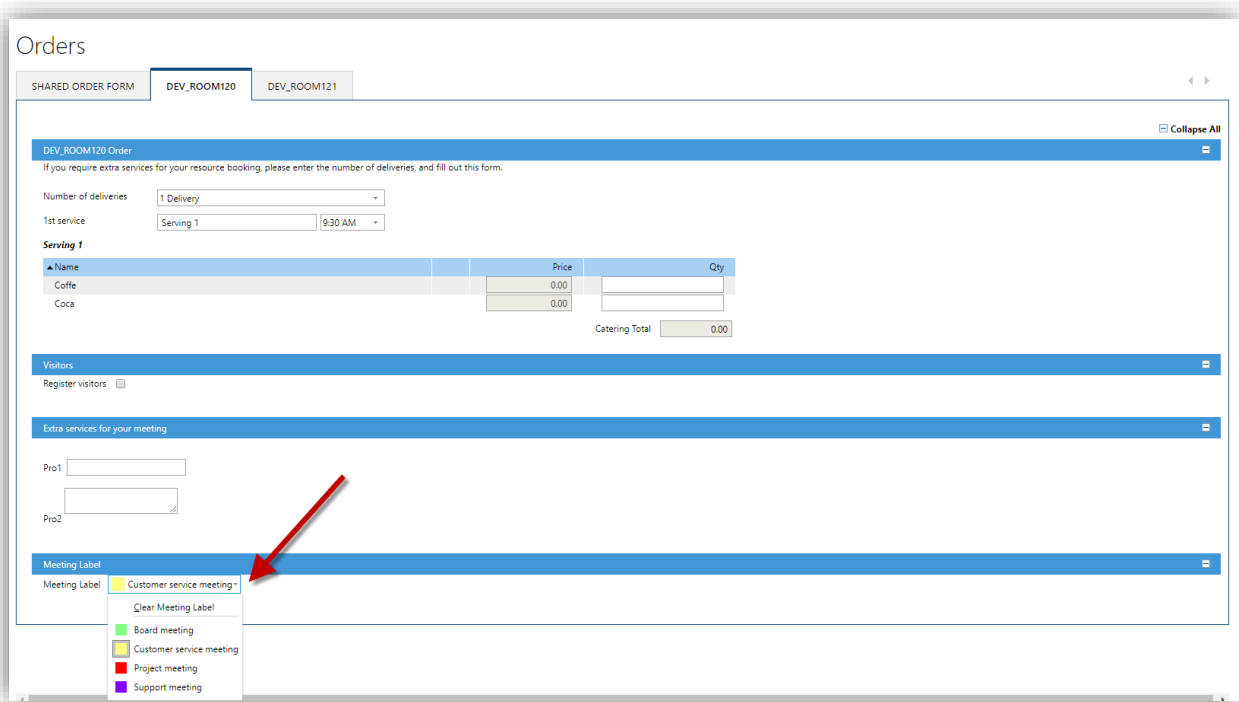

Figure 309. Meeting type in Order Form



NOTE: The color coding only supports Standard Order Form, it has no effect on Shared Order Form.

Resource Type

In this section you can configure labels for resource types, which can be seen in **ResourceFinder Reservations**, **Booking Manager**, and **Resource details**.

SAVE

Resource Type

Room*

Rooms Language

Desk*

Desks Language

Equipment*

Equipment Language

Misc*

Misc Language

Figure 310. Resource Type configuration

Type in the labels of your preferences for four types of resources and the custom languages needed, then click [**Save**] to finish.

A tab is shown when resources are configured to belong to a resource type.

Help

A help function can be configured for different parts of the system. This will allow setting up guides for users to access easily when in need of help. The help function can either be a PDF-document or a link to a webpage. When configured a question mark icon will appear and when pressed it will direct the users to the document or webpage for the relevant sections of Resource Central and ResourceFinder:

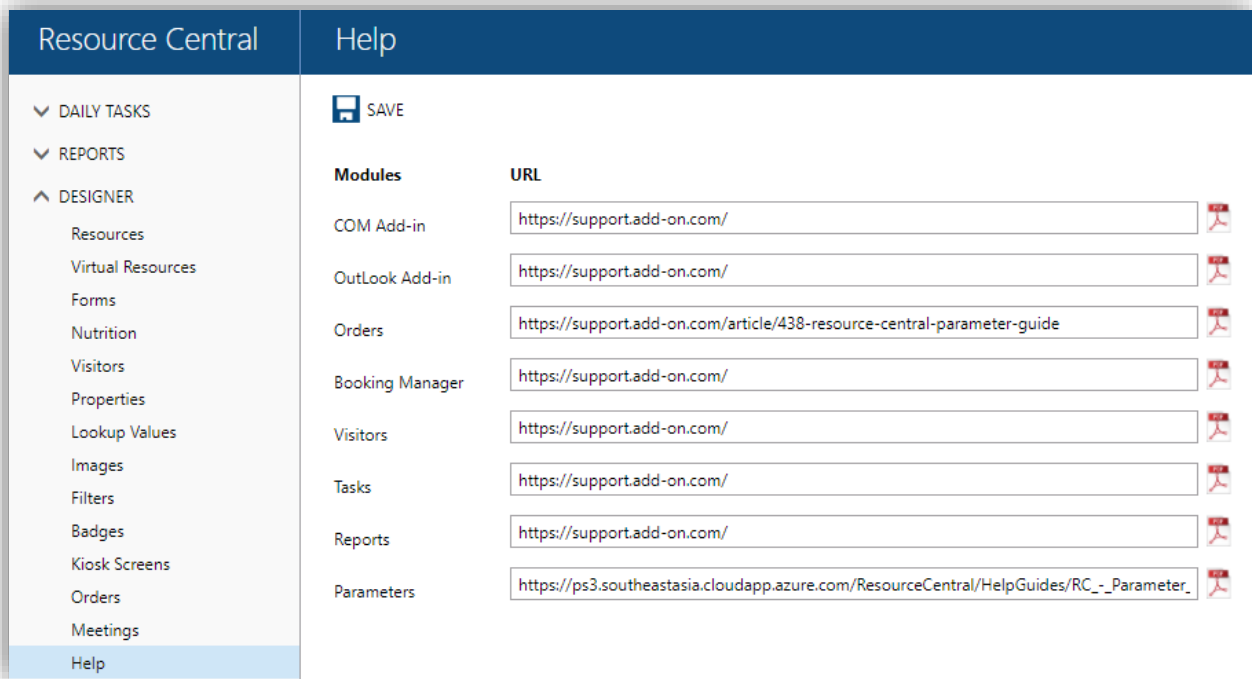



Figure 311. Help Configuration

You can insert a URL to a specific webpage or upload the PDF file to be used by clicking the  button. After uploading, the URL to the uploaded file will be automatically filled in.

Tax Receipt

This section is only available when the parameter **TaxReceipt.Enable** is set to '1', meaning the feature 'tax receipt' is turned on. In this section, you can make all configurations for the tax receipt feature.

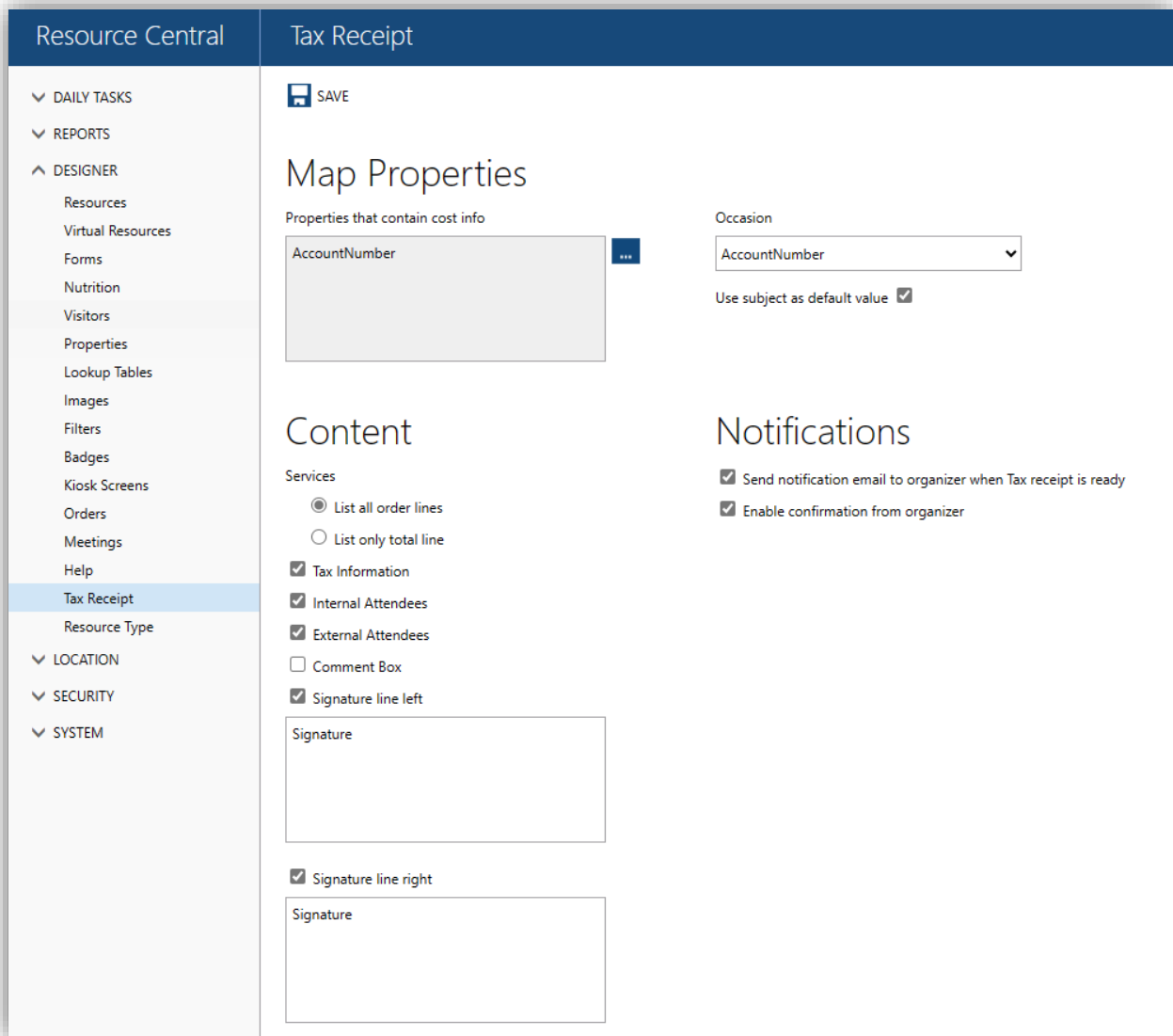

Figure 312. Tax receipt configuration

Field	Description
Map properties	
Properties that contain cost info	Select the properties that contain cost information
Occasion	Select the properties that contain occasion information. This can be filled out with the meeting subject per default by selecting the checkbox under it (Use subject as default value).
Content	This section will allow you to select details that you want to have on the receipt. NOTE: If Internal Attendees is turned off, the textbox for internal attendees will not be displayed in the order form.
Notifications	

Send notification email to organizer when Tax receipt is ready	Organizer will get notified when a Tax receipt draft or a Final Tax receipt has been sent.
Enable confirmation from organizer	When enabled, the organizer will be prompted to confirm or decline the Tax receipt draft. When disabled, the order status will change directly to 'Locked' and only the Final Tax receipt is sent to the organizer.

For detailed information on how the tax receipt feature works, please refer to this [appendix](#).

Location

Locations

When navigating through the **location tree**, you will be able to see related **resources**, **users**, and **items** at the node where they are represented. You can also see how many **resources/users/items** can be found in **sub nodes**. Clicking a **sub node** will expand the **left-hand side tree view** and move the focus to the selected node.

Items/persons at root level of the location tree will be available to all resources in the application. **Items/persons** nearest to a resource position in the location tree will be assigned to that particular resource (in upward direction towards location tree root).

Resource Central	Locations			Host (Security)
<ul style="list-style-type: none"> ▼ DAILY TASKS ▼ REPORTS ▼ DESIGNER ▲ LOCATION <li style="background-color: #e6f2ff;">▲ Locations <li style="padding-left: 20px;">▲ Europe <ul style="list-style-type: none"> France Germany <li style="padding-left: 20px;">▲ Asia <ul style="list-style-type: none"> Japan Korea <li style="padding-left: 20px;">Categories ▼ SECURITY 	▼ Persons	▲ Resources	▲ Items	
	John Smith	Conference Room 0103	Cake	
	Host (Security)	Meeting Room 004	Coffee	
			Tea	

Figure 313. Locations: Persons, Resources and Items at a particular location

Clicking any of the **Persons / Resources / Items** at any level will take you to the details of that entity.

You can also drag a location and move it to combine with another one. This can be applied to both child locations and parent locations. For example, in the above figure you can move the whole **Asia** location to combine with **Germany**. All these changes will be applied to Location tree in Resource Central and ResourceFinder.

Floor plans

To help find the location, you can add an image of a floor plan leading to it or an image of the compound map that can help people locate the destination. To do so, select a location and click **[Floor Plan Configuration]**:

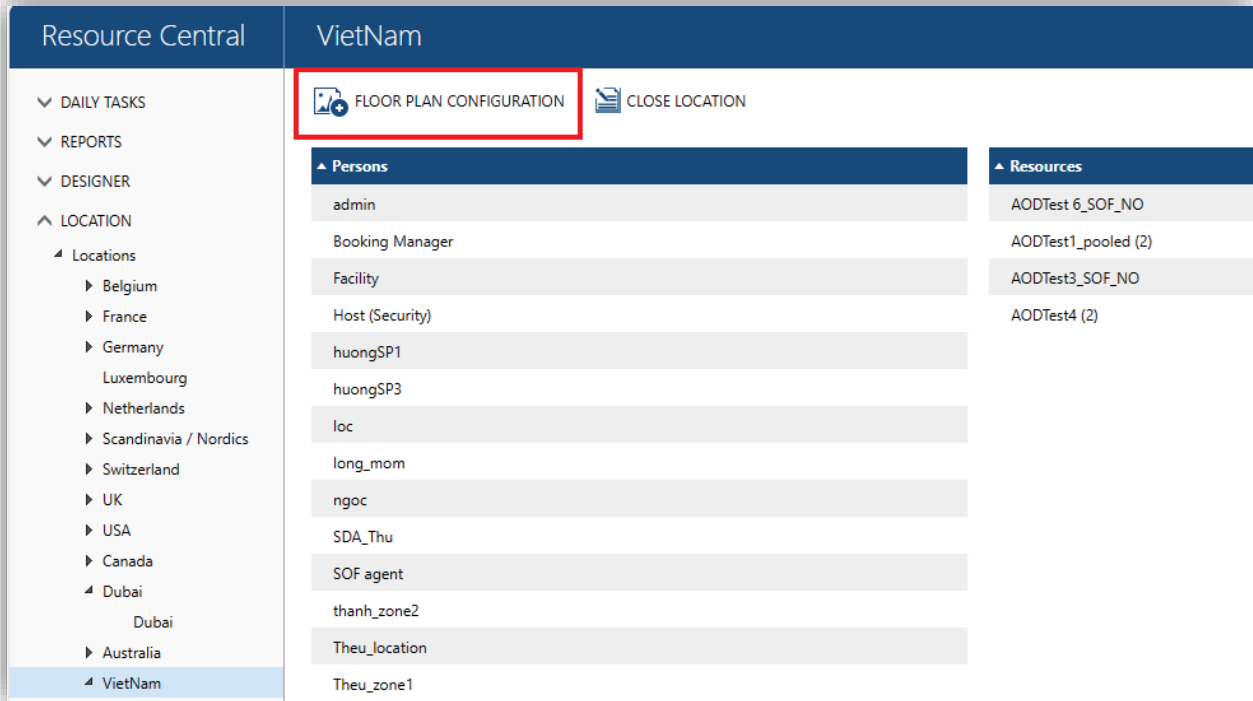

Figure 314. Go to Floor Plan Configuration

On Floor Plan Configuration screen, click **[Select Image]** to pick up the floor plan image from your 'Images' category under **DESIGNER** section.

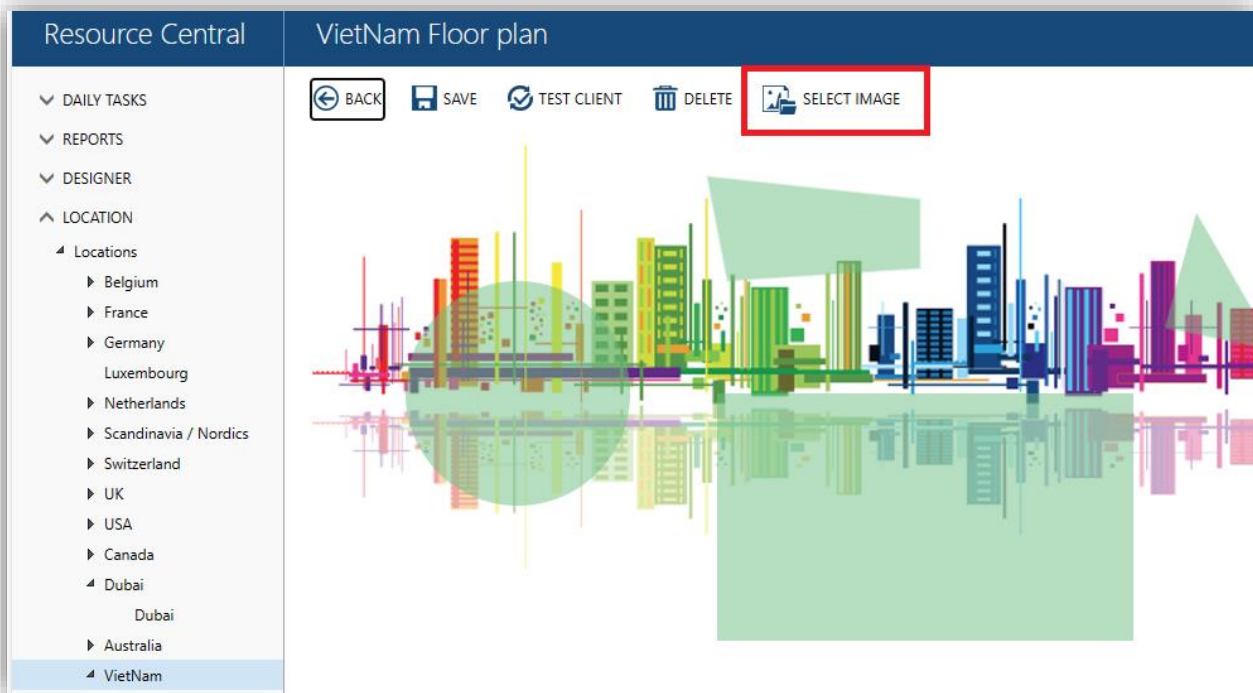

Figure 315. Select image of floor plan

After selecting the image, the floor plan will be shown on this screen in which you can map a resource with a specific location on the floor plan, so that organizer knows better about a resource's location.

NOTE: From RC4.3 SR1, you are supported to set up floor plan for Virtual Resources.

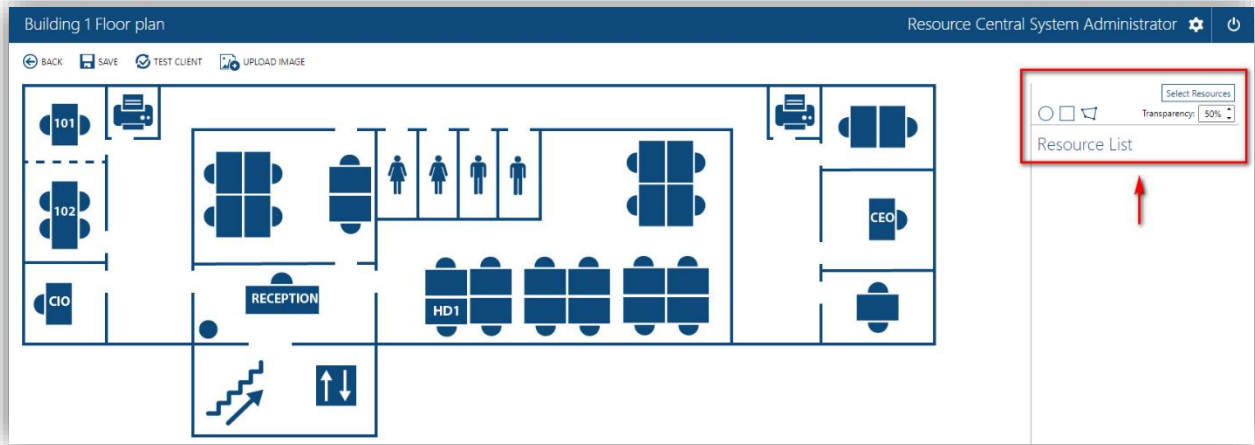
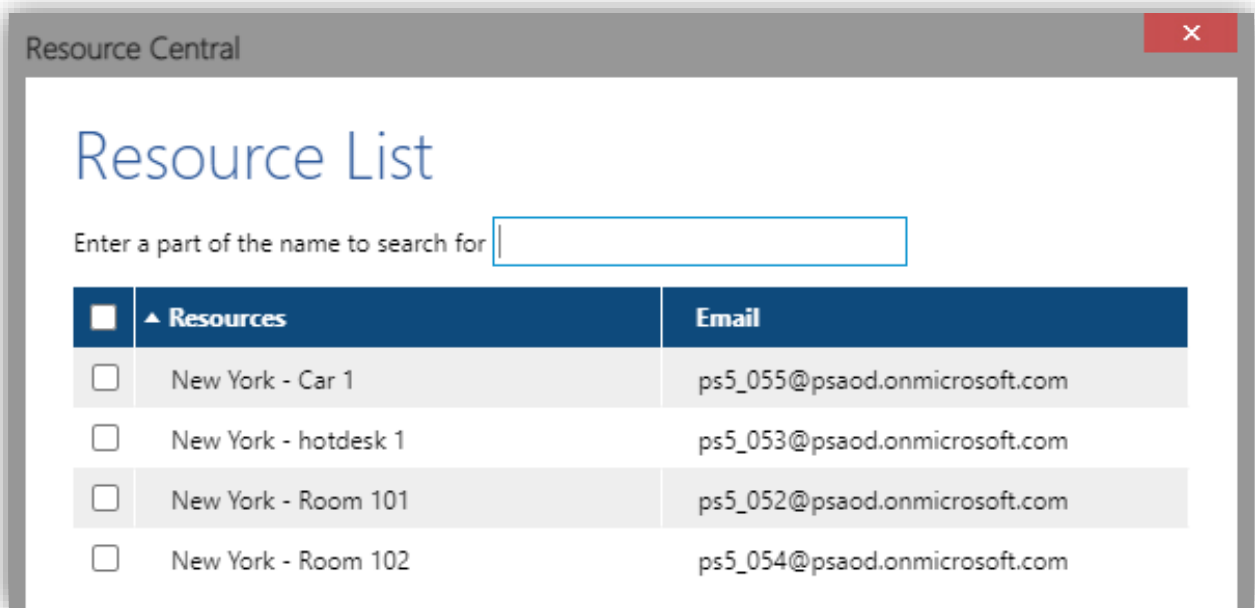

Figure 316. Resource mapping

Click [**Select Resources**] to add a resource to the list. You can search for it from the pop-up window:



After adding all necessary resources, you need to select a resource from the list on the right panel...



...then select a shape...

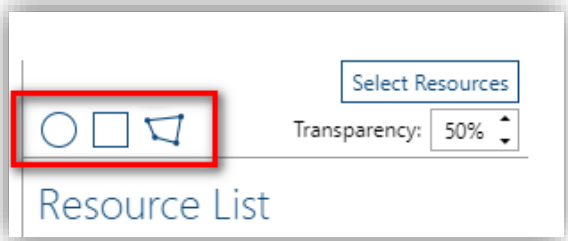

... and put it on the floor plan:

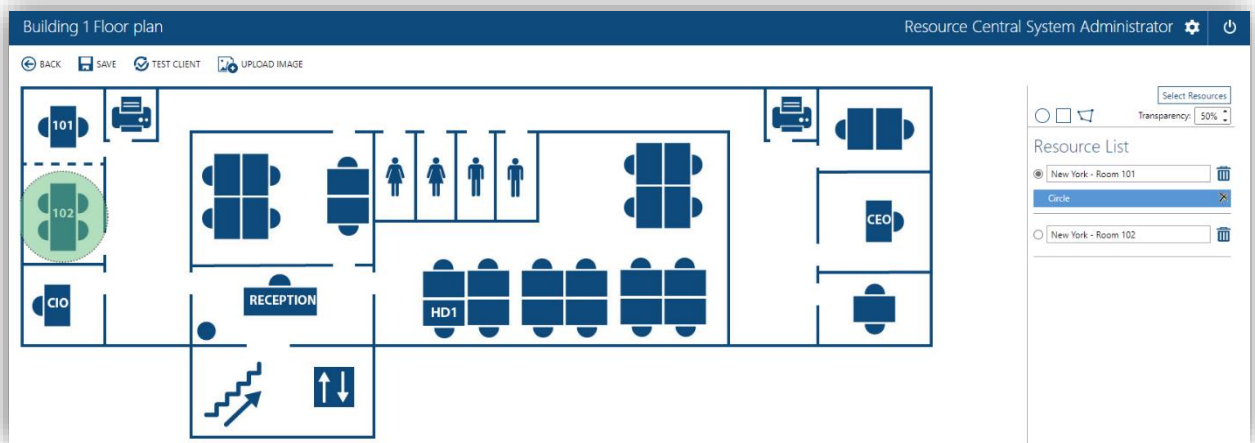

You can see in the above example, the shape [Circle] is selected for the resource 'New York – Room 101', and a circle is put into the floor plan.

You can do the same for the other resource. You might select a similar shape (Circle) or different shape (Rectangle or Polygon), and this is the result:

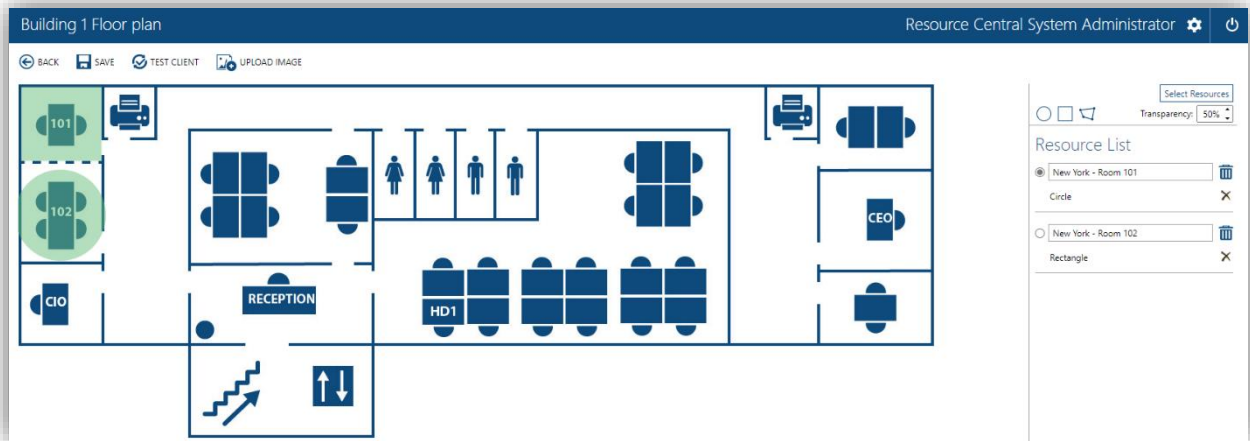

Figure 317. Floor Plan with mapped resources

Then click [**Save**] to finish. You can see the result in [Floor plan](#) section in **ResourceFinder**.

NOTE: Click on [**Test Client**] to know how this feature works on client side.

You can also the name of floor plan image by selecting a location, right-click, and select Properties, which opens the following screen:

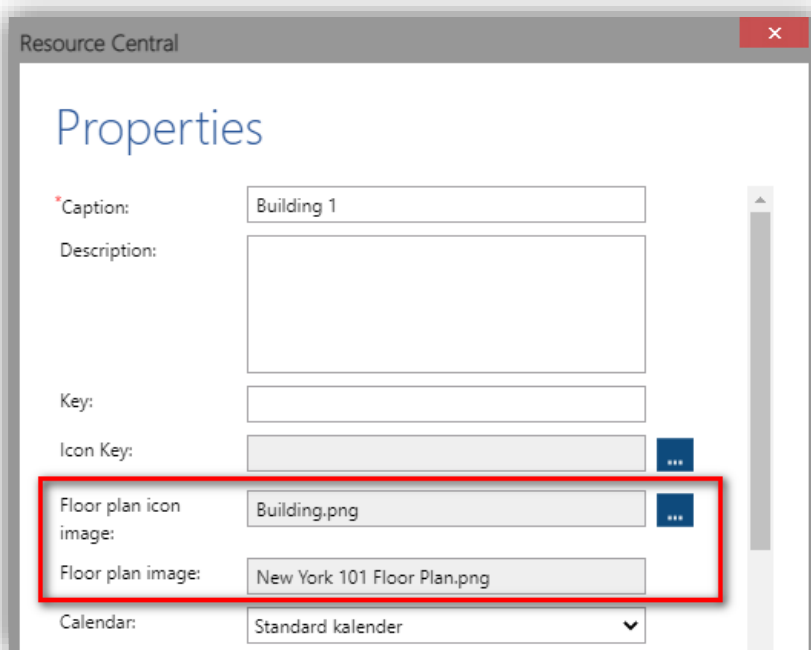
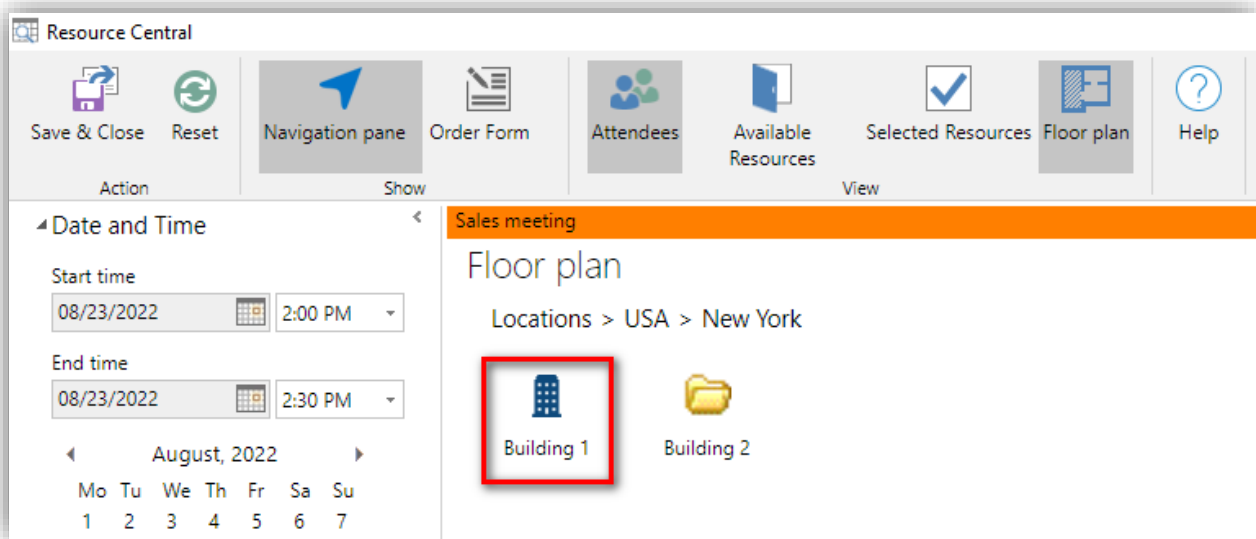

Figure 318. Location's Properties

Here you can see the floor plan image name at 'Floor plan image' field.

Also, you can change the 'Floor plan icon image' by clicking the [...] button of this field, which will prompt an image list so that you can choose an icon for the location.

When you are done, click [**Save**]. The icon will be displayed on **ResourceFinder**, e.g.:



NOTE:

- You can select any image from the list. If you want to upload image to this list, go to **Admin Interface → Designer → Images**.
- Image with size up to 2.5 MB can be uploaded. However, images under 500 KB (or as small as possible) are recommended if there are too many images to be uploaded.

On the Properties screen of a location, you can also configure utilization percentage that will be applied to all resources included in the calculation for that location.

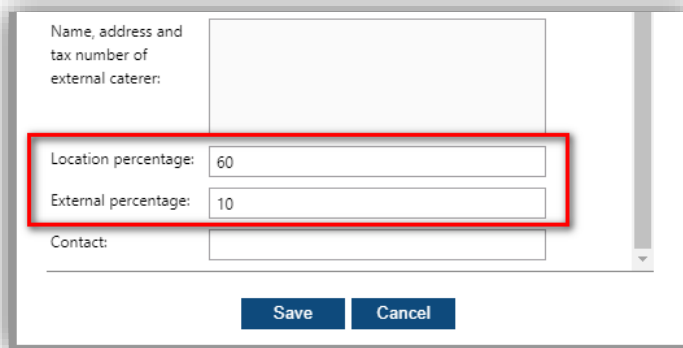

Figure 319. Utilization percentage

Location and external percentages

Location and external percentages can be used to limit the utilization of the total number of desks on a location without having to disable the resources in Exchange.

The feature applies to all license types and is configured on the individual resources by setting the **Include in utilization calculation** option to Yes.

When the utilization percentage is applied to Standard or Light Resources, the capacity of the resource is required to be and is automatically set to 1 for the calculation to work as intended.

This feature is therefore not intended to be used for Rooms or other resources, where you need the capacity to be bigger than one.



NOTE: If the capacity is violated either when organizer uses native Outlook to book excessive capacity or if the one of the percentages is changed leading to overcapacity, organizer will receive decline emails from Exchange with a message from Resource Central on why the resource reservation was declined.

Location percentage

The Location percentage can be used alone or in association with the External percentage.

E.g., if you want to reserve 50% of the desks for employees who are always in the office and make the remaining 50% available for booking by employees that shift between office and home office and therefore do not need a fixed office desk.

When used alone (External percentage is left blank), the Location percentage will control how many of your light resources or Pooled resources can be booked.

The utilization calculation for a location is done per Pooled Resource while Standard/Light are calculated as a total group from which the percentages are deducted to give the available number of resources for that location.

Example 1 - Booking a Pooled Resource:

Conditions:

- Location percentage is set at 50.
- 1 Pooled Resources with capacity of 10

Scenario:

- Organizer A wants to book Desk Pool 1 and will in ResourceFinder see the resource 'Desk Pool 1' showing a capacity of 5 (50% of 10).

Example 2 – Booking Light Resources:

Conditions:

- Location percentage is set at 50.
- 8 Light Resources

Scenario:

- Organizer A wants to book 5 Light Resources and will in ResourceFinder see all the Light Resources with capacity of 1.
- Organizer A can then select up to 4 (50% of 8) and after that prevented from selecting more resources.

External percentage

The external percentage is used if you want to reserve X percent of the resources for certain employees.

E.g., if you have multiple sites with employees going back and forth between the locations, then you can set up the X percent of the desks to be reserved in each site for employees visiting this site on a regular basis. This will give this “visiting” employee a better opportunity to find available seating as the employees normally working at the site cannot take up all available seats.

Or if employees have default workplace on one floor, seats can be reserved for them on other floors in case they cannot find an available seat on their default floor, and they must go to the office.

The calculation of the external utilization is based on where the organizer and the resource are located. This is controlled through the Active Directory where AD groups are mapped on users and resources for later comparison in ResourceFinder. See a more detailed description of this [here](#).

You can configure when the resources are made available for all employees as a number of days. So, if your booking start date does not exceed the number of days, then the resource can be booked by all.



If it is longer, X percentage of the resources are reserved.

This setting is controlled by the parameter **ResourceFinder.ExternalPct.DaysReserved**. Please refer to **RC Parameter Guide** for more details.

Example 3 - Booking a Pooled Resource:

Conditions:

- Location percentage = 50
- External percentage = 20

- Organizer A is in the AD-Group 'IT'.
- Organizer B is **not** in the AD-Group 'IT'.

- The resource 'Desk Pool 1' has a capacity of 10 and is in the AD-Group 'IT'.
- The parameter **ResourceFinder.ExternalPct.DaysReserved** is set to 3.
- 'Today' is the 10th of April.

Scenario:

- Organizer A is creating a booking for 20th of April.
The resource 'Desk Pool 1' will show a capacity of 5 (50% of 10) because 'Organizer A' is in the same AD-Group as the resource.

- Organizer B is creating a booking for 20st of April.
The resource 'Desk Pool 1' will show a capacity of 2 (20% of 10) because 'Organizer B' is **not** in the same AD-Group as the resource.

Example 4 – Booking a Pooled Resource:

Conditions:

- Location percentage = 50
- External percentage = 20

- 'Organizer A' is in the AD-Group 'IT'.
- 'Organizer B' is **not** in the AD-Group 'IT'.

- The resource 'Desk Pool 1' has a capacity of 10 and is in the AD-Group 'IT'.
- The parameter **ResourceFinder.ExternalPct.DaysReserved** is set to 3.
- 'Today' is the 10th of April.

Scenario

- Organizer A is creating a booking for 12th of April.
- The resource 'Desk Pool 1' will show a capacity of 7 (50%+20% of 10) because Organizer A is in the same AD-Group as the resource and the date of the booking is inside the window defined by the **ResourceFinder.ExternalPct.DaysReserved** parameter.

Different rules to be aware of

When using the percentages and Pooled resources together, the organizer can still book for other employees, but whether the organizer is considered as part of the location or external percentage set on the location will dictate the booking rules.

If the organizer is part of the utilization percentage, all attendees will be the same even though some of them might be included in the external percentage if booking the resource themselves and vice versa.



If the organizer or one of the attendees already have booked the same Pooled Resource on the same day, they will only be counted once. Therefore, they will not take up several of the available desks.

Team leaders can book for teams, but if they do not need to use the resource themselves, they need to book through one of the team members' calendars.

When the system administrator lowers the percentages, future reservations exceeding the new capacity levels will be declined by Resource Central. It cannot be controlled which reservations will be declined.

NOTE: In the case when you are changing an existing room with capacity higher than one to be included in the utilization calculation, Resource Central will automatically set the capacity to one at Save and will delete all future reservations on this resource where the bookings exceed a capacity of one.

Location that requires visitor authorization

Certain locations may require authorization to allow visitors to come in. In this case, you can enable those locations to require visitor authorization.

To do so, right click on a Location and click [**Properties**]. You will see the following checkbox:

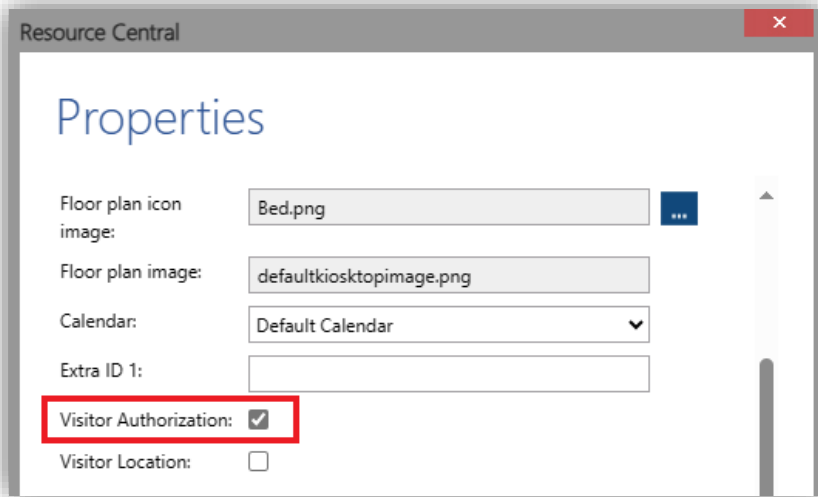

Figure 320. Location Properties – Visitor Authorization

If the 'Visitor Authorization' option is checked, visitors in this location will need authorization before they can be checked in (for more details on the visitor authorization process, please refer to [this section](#)).

The person(s) who is in charge of authorization process are specified in **Security → Persons** and **Security → Roles**.

If the 'Visitor Authorization' option is unchecked, the visitors in this location can be checked in as usual without the need of authorization.

Visitor location feature

This feature controls the ability to select specific locations when registering visitors in My Meetings or in the Visitor Module. The default value of this field is "Enabled" (checked).

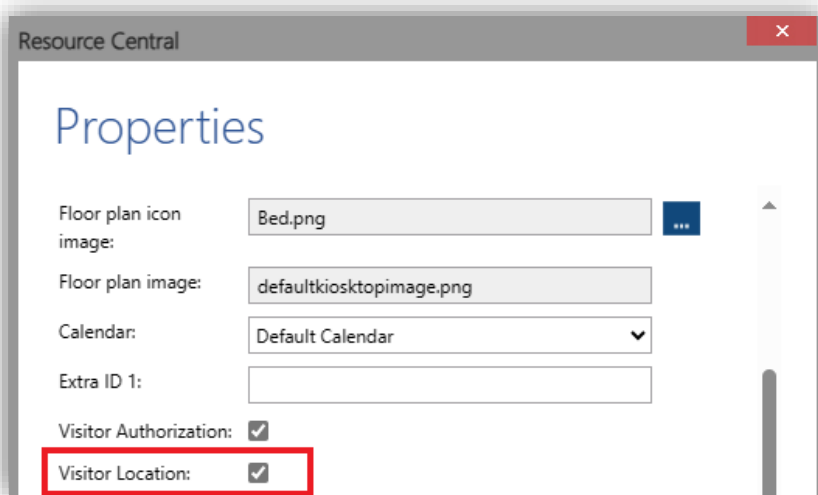

Figure 321. Location properties – Visitor Location

- If the 'Visitor Location' option is checked, the location will be available to be chosen when registering new visitors.
- If the 'Visitor Location' option is not checked, the location will be grayed out and crossed out which means it cannot be selected when registering new visitors.

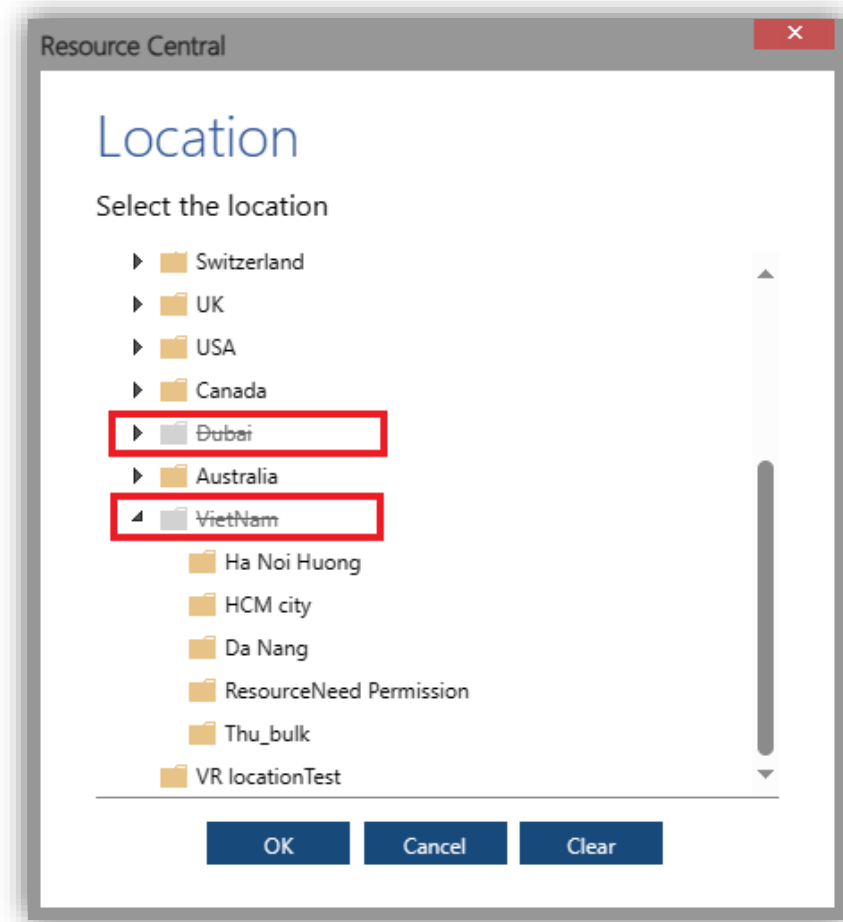

Figure 322. Visit Location feature disabled

Visitors booked in for meetings in a resource under an unchecked Visitor location will still appear under this location.

Close Location

In some cases, a location may need to be closed for various purposes. This feature will allow you to set a closing period for the location. Setting a closing period for a location will apply to all resources belonging to it, meaning these resources cannot be booked in the specified period.

This feature is available when the parameter **RC.ClosedPeriod** is set to '1', meaning the feature is turned on (refer to **Resource Central Parameter Guide** for more details).

To close a location, select a location and click **[Close Location]**:

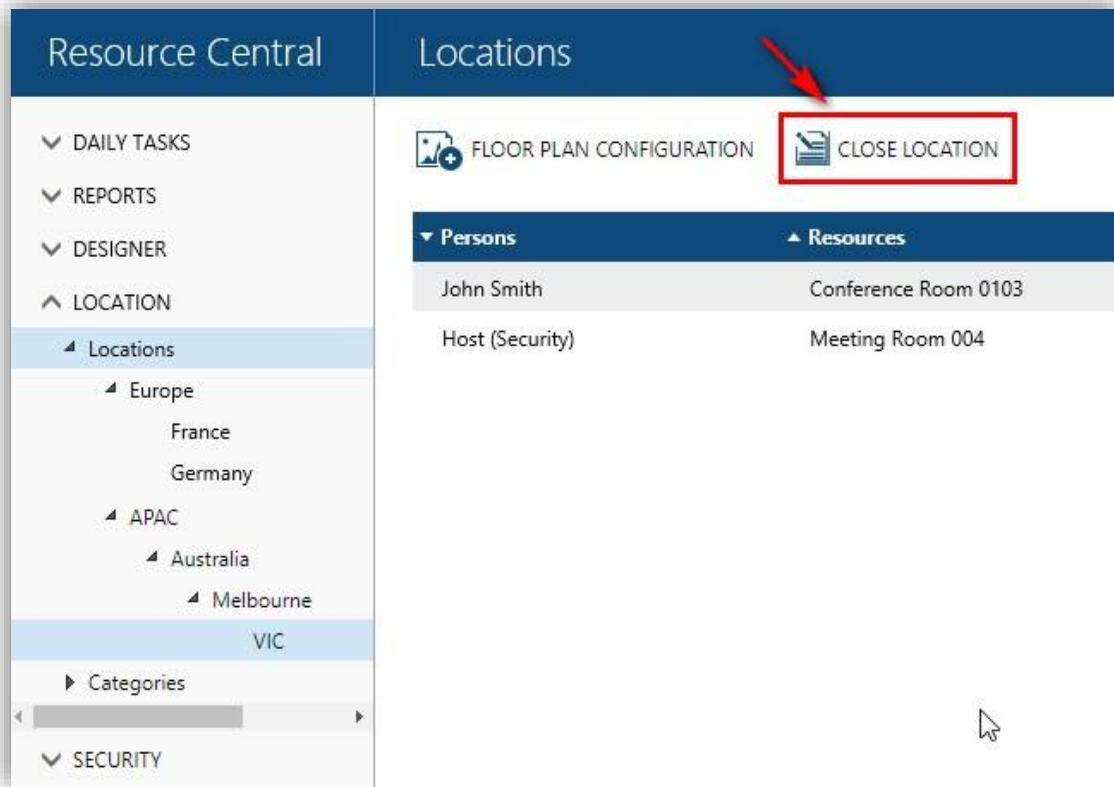

Figure 323. Close location

The Close Location panel is as follows:

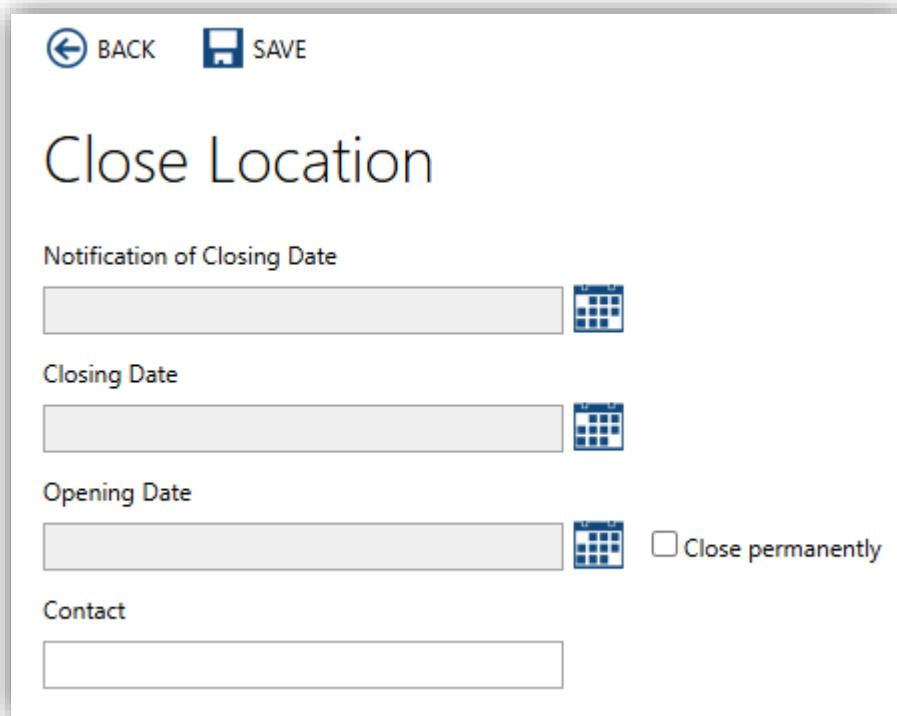

Figure 324. Close Location interface

Field	Description
Notification of Closing Date	The date to send email to organizers notifying beforehand that resources in the location are going to be closed. And start showing in ResourceFinder that the location and its resources are going to be closed.
Closing Date	The start date when resources in the location become closed (unavailable).
Opening Date	The date when resources in the location become opened (available again).
Contact	This Contact information will be included in the notification email that warns organizers about the closing schedule. Enter e.g., email address or phone number of the Contact person.

Checkbox	Description
Close permanently	If you check on this option, the location will be closed permanently from the Closing Date.

Click [**Save**] on toolbar to save the changes.

On ResourceFinder, warning icons will be shown for resources that have closing and opening dates:

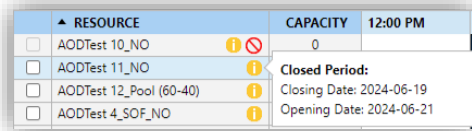

Figure 325. Warning before closing date

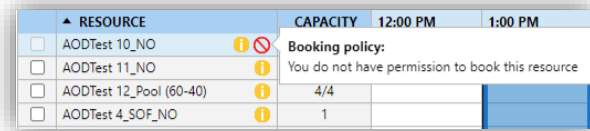

Figure 326. Warning within closing & opening date

If the location is closed permanently as of the Closing Date, warning icons will be shown for its resources as follows:

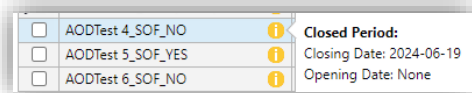

Figure 327. Warning before closing date



Figure 328. Warning within closing

In RC backend → **Locations**, you can either:

- Edit the Close Location fields of a location. Then all resources belong to it will follow the edited dates.
- Click [**Delete**] button (only appears if previous close dates are saved). With close dates deleted, all resources in the location will become available again.

NOTE:

1. If the closed location has child locations, the child locations and their resources will NOT be affected by the closure of the location.
2. If a location has set closure period, its respective resources will follow that closure period. Also, those resources cannot set closure period individually (refer to [Resource Closure](#)).
3. If a resource change to a new location, there are two possible scenarios:
 - New location has its own closure period: the resource will follow its new location's closure period.
 - New location does not have closure period: the dates set on the resource will be removed.

If there are resources already booked within the closure period, clicking [**Save**] will prompt the following message:

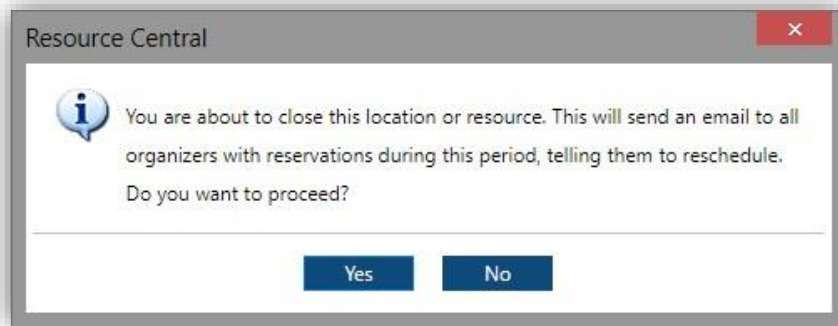

Figure 329. Closure prompt

Confirming [**Yes**] will send the following email to the organizer:

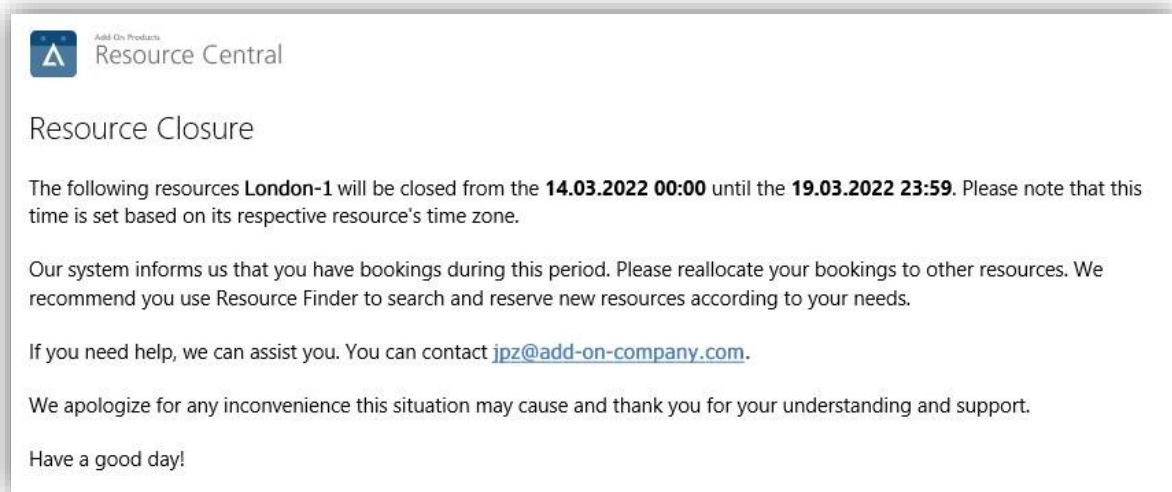

Figure 330. Resource closure email

This email will be sent following the “Notification of Closing Date”. If no Contact information specified in the Close Location page, this email will not include any contact information.

This will not cancel the meeting, giving the organizer time to change to another resource or select a different meeting date that is outside the closed period.

For more details on **meeting/reservation cancellation scenarios**, please refer to [this section](#).

Categories

The categories are created in order to tag Resources according to their different attributes. This will make it easier for the organizers when searching for resources that should fulfill specific needs for a meeting. E.g., being a room being teleconference-enabled or an office desk with docking station for a day at the office.

In the root categories, you can establish default categories to be displayed when organizers open ResourceFinder for the first time:

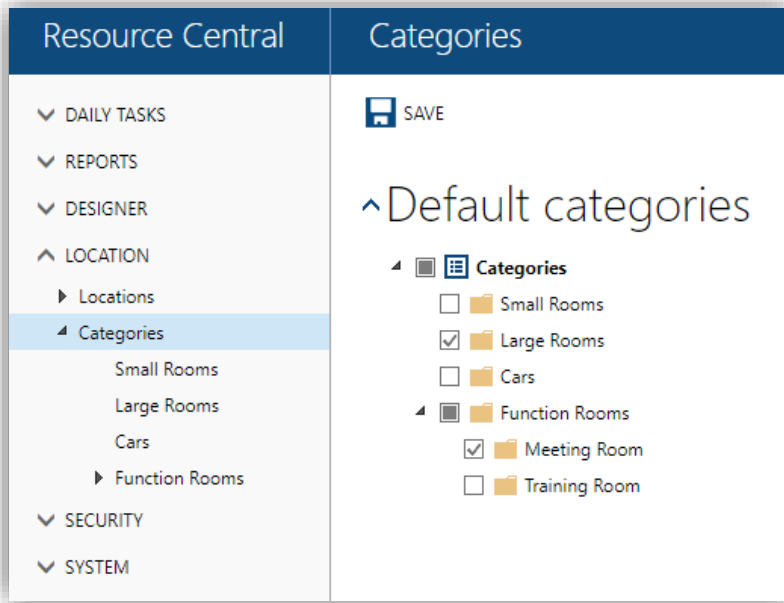

Figure 331. Set up default categories

It can also be established in each category's properties:

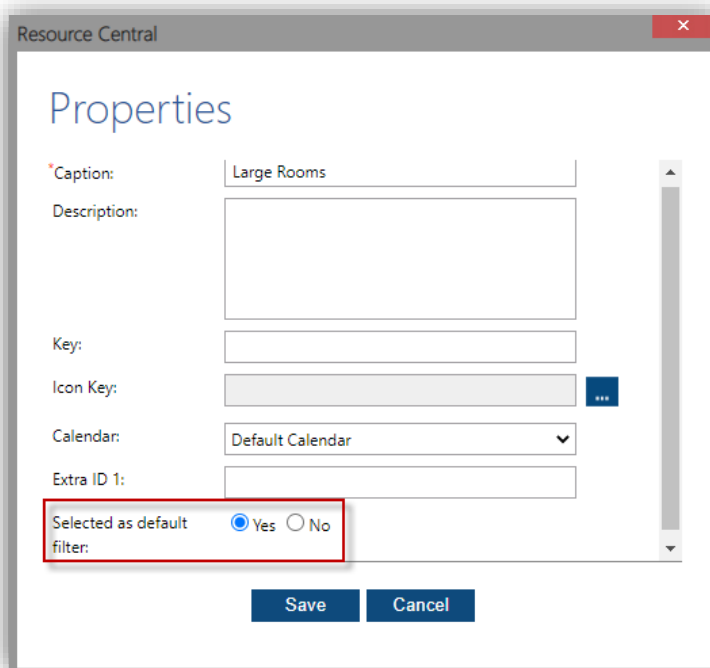

Figure 332. Category's properties: Set up default filter

The selection made in this menu will be reflected in ResourceFinder of both COM Add-in and Outlook Add-in. Organizers can make their own default filter by going to ResourceFinder/Settings/Default Filter.

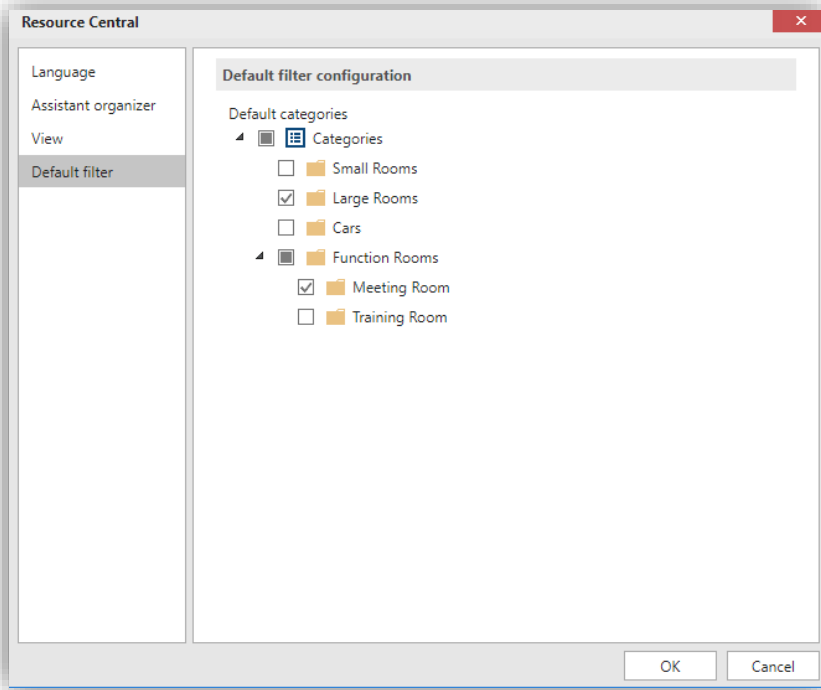

Figure 333. Settings: COM Add-in

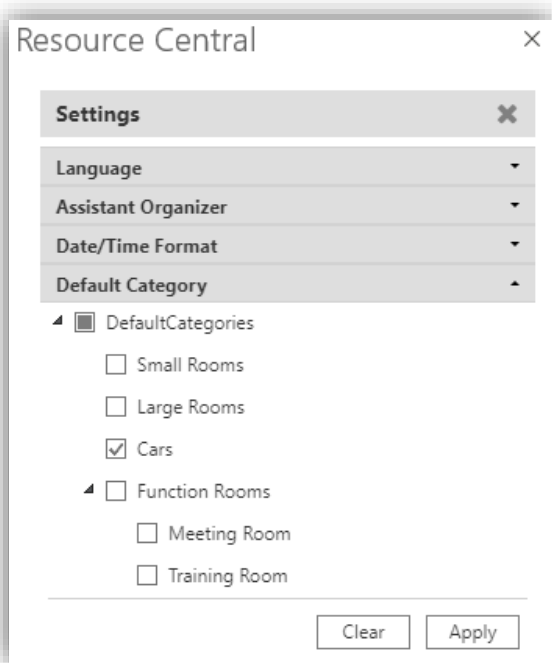

Figure 334. Settings: Outlook Add-in

New and updated default settings made from the backend will be available for all users, until they start making their own adjustments to their filter.

Zones

NOTE: This section only appears if the **Enable Zones** option is checked in Visitors section (refer to [Other Visitor settings](#)).

You can create a zone that includes multiple locations as well as persons who are in charge of them.

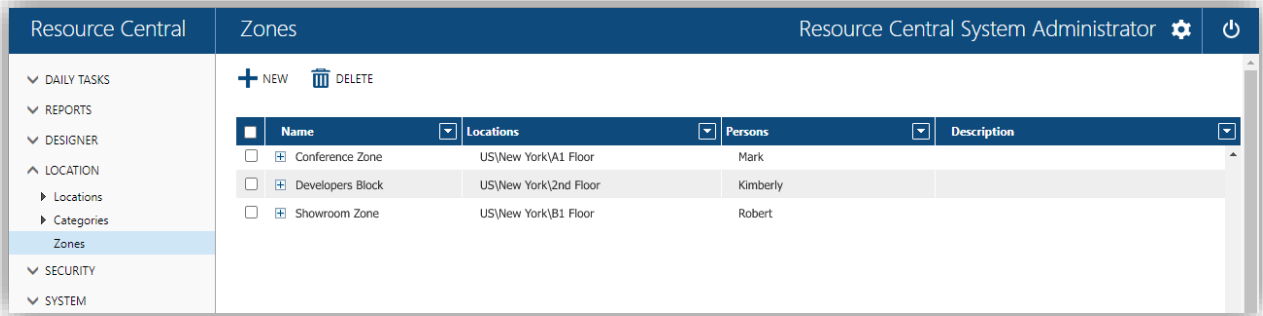

Figure 335. Zones list

Toolbar Buttons	Description
NEW	Create a new Zone
DELETE	Delete the selected zone(s)

Clicking on a zone will show **details** about it.

Zone details

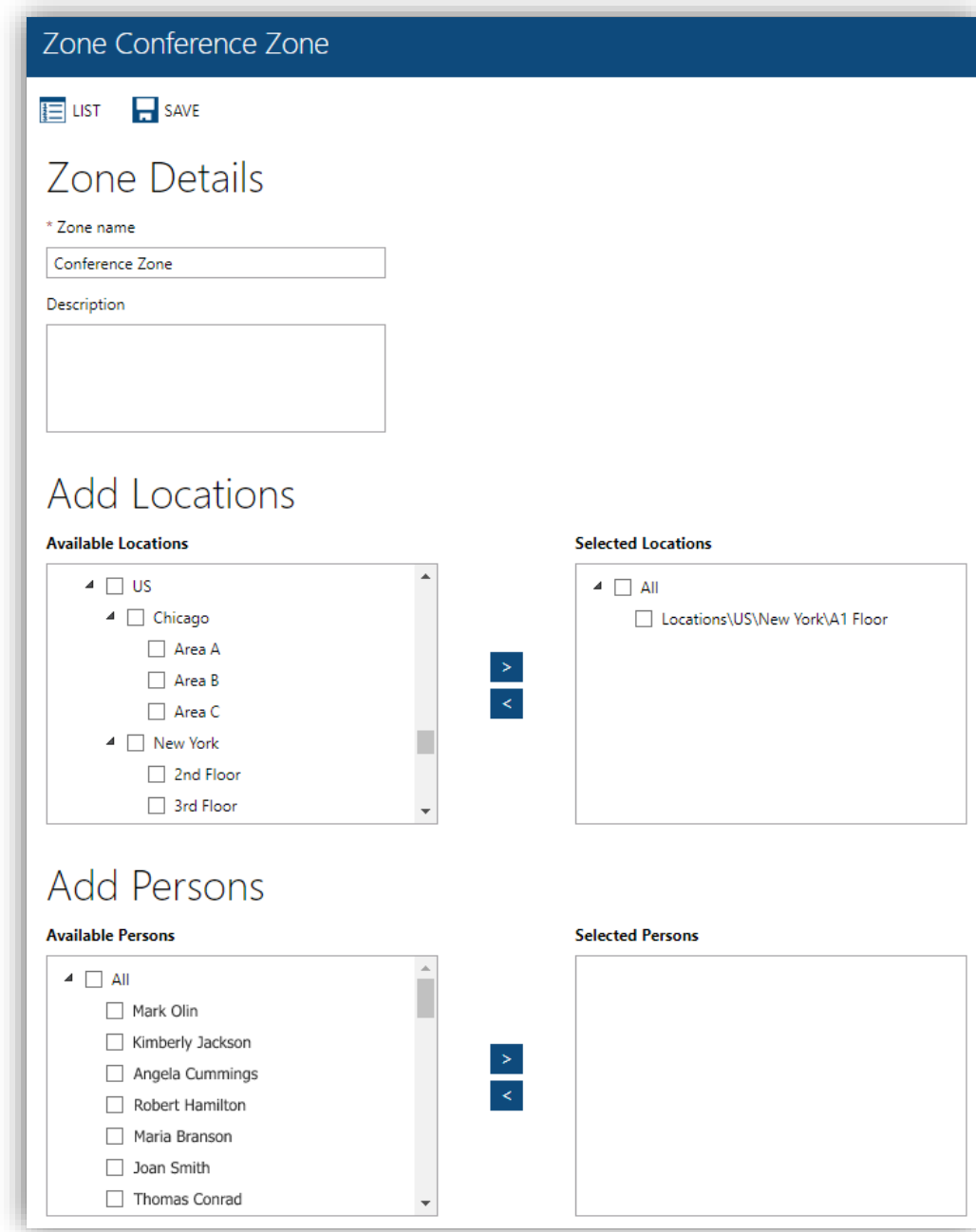

Figure 336. Zone details

Field	Description
ZONE DETAILS	
Zone name	Name of the zone.
Description	Description of the zone.
ADD LOCATIONS	
Available Locations	Select among available locations to add to the zone. To add selected locations, click [>] and they will be moved to the 'Selected Locations'.
Selected Locations	Show the locations that are added to the zone.

	To remove them from the zone, select those locations and click [<].
ADD PERSONS	
Available Persons	Select among available persons who would be in charge of the zone. Also, added persons with visitor-approval roles will be able to decide visitor status for those who would visit the zone where added persons are in charge. To add selected persons, click [>] and they will be moved to the 'Selected Persons'.
Selected Persons	Show the persons that are in charge of the zone. To remove them from the zone, select those persons and click [<].

Toolbar Buttons	Description
LIST	Return to the zone list.
SAVE	Save changes made to the zone.

Security

Persons

It contains person definitions of all the persons defined in the Resource Central

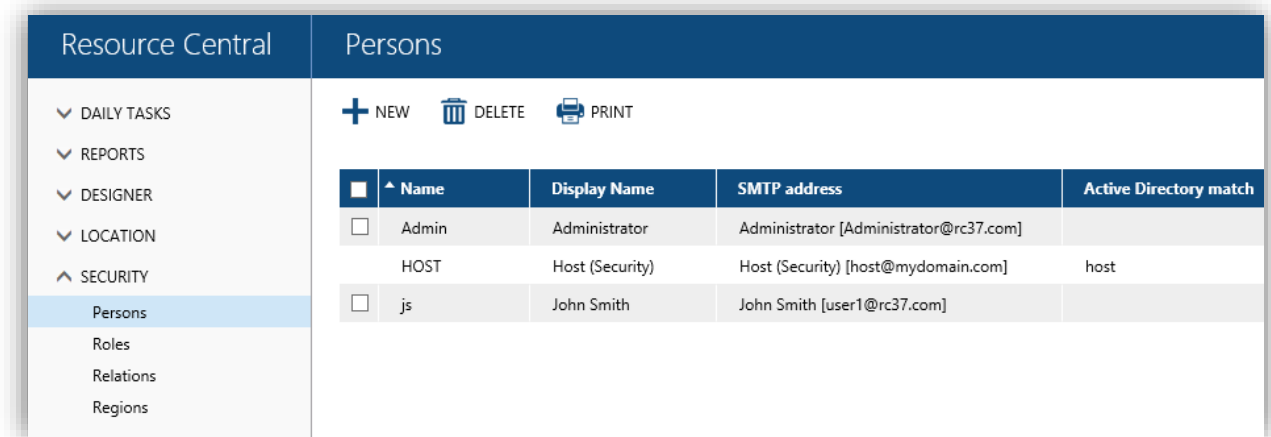

Figure 337. List of Persons

Toolbar Buttons	Description
NEW	Create a New person
DELETE	Delete the selected person(s)
PRINT	Print the screen

Clicking one of the user records will show **details** about it.

Person Details

Viewing a given person record, you can **edit** and **save** changes, or use **[Roles]** to maintain the **view** and **edit** the **role relation** for the person. Use **[Assignments]** to see the **Role/Resource relation** and use **[Set Password]** to set the password for the person.

NOTE: A person whose password is not set cannot log into the Resource Central Admin application.

Figure 338. Details of a Person

Field	Description
Login Name	Name used for login to Resource Central
Display Name	Name shown in reports
SMTP Address	The SMTP address of the person
Description	A short description. Max 255 characters
Active Directory match	Value corresponding to the ASP server variable value " AUTH_USER " - used for integrated login to Resource Central
Language	Language for this person. Once a language is specified, all the application interfaces and emails sent to this person will be in that language.
Locations	Locations that this person has responsibility for. These locations must be defined in Location tree under Locations node. If RBAC option (located in SYSTEM → Authentication → Person Authorization – RBAC) is NOT enabled, the Person's locations will be prioritized over his/her Role's locations. If RBAC option is enabled, the Person's locations will be overwritten by his/her Role's locations instead.

	<p>3. (For more details on RBAC feature, refer to this article)</p> <p>NOTE: When a person who will play the role of a service provider for Shared Order 1.0 feature is created, Location must be defined as ROOT location.</p>
Zones	<p>Select zones in which this person will be designated to.</p> <p>This field will not appear if the Enable Zones option is unchecked under Designer → Visitors (refer to Other Visitor settings)</p>
Authorization	<p>List of the Location(s) requiring visitor authorization that is designated to this person.</p> <p>Zones added in 'Zones' field above will also be shown in the list.</p> <p>NOTE: You need to click [Save] on toolbar to actually see the changes to this field when you edit 'Zones' & 'Locations' fields.</p>
Time Zone	<p>Time Zone of the person (user). The reservation & serving times are displayed according to person's Time Zone (This field is not mandatory)</p>
Time Format	<p>Time format to be followed across all the emails (in the Order Processing in RC Application) sent to this person.</p> <p>If the value is not specified in this field, then the value defined in the Basic Parameter will be used.</p>
Date Format	<p>Date format to be followed across all the emails (in the Order Processing in RC Application) sent to this person.</p> <p>If the no value is not specified in this field, then the value defined in the Basic Parameter will be used.</p>
Date Separator	<p>Date Separator to be used in the dates across all the emails (in the Order Processing in RC Application) sent to this person.</p> <p>If the value is not specified in this field, then the value defined in the Basic Parameter will be used.</p>
RBAC User	<p>This option cannot be checked manually. It is automatically checked when the user is synced with Azure AD.</p> <p>When checked, the user becomes a RBAC user whose information and app role are synced with RC role, based on the user's Access token claims from AAD.</p> <p>For more details on RBAC feature, refer to this article.</p>

Toolbar Buttons	Description
Save	Saves the information edited in the Input fields
List	Displays the list of Persons
Roles	Displays the list of roles assigned to this Person (see details below)
Assignments	Displays the assignments of this person (see details below)
Set Password	Displays the controls for setting up password (see details below)
Save Configurations	The values in all of the fields will be saved so that the next time when you click NEW to create a new person, all of the fields will be pre-populated with those saved values. (Value in the 'Login Name' & 'SMTP Address' fields will not be saved)

Person: Roles

This will show the roles associated with the person. To add roles from a list for the person select **[Add Role]**. Mark the **check box** in front of the role and select **[Delete]** to delete that role. Click on **[Person]** to go back to **Person detail view**.

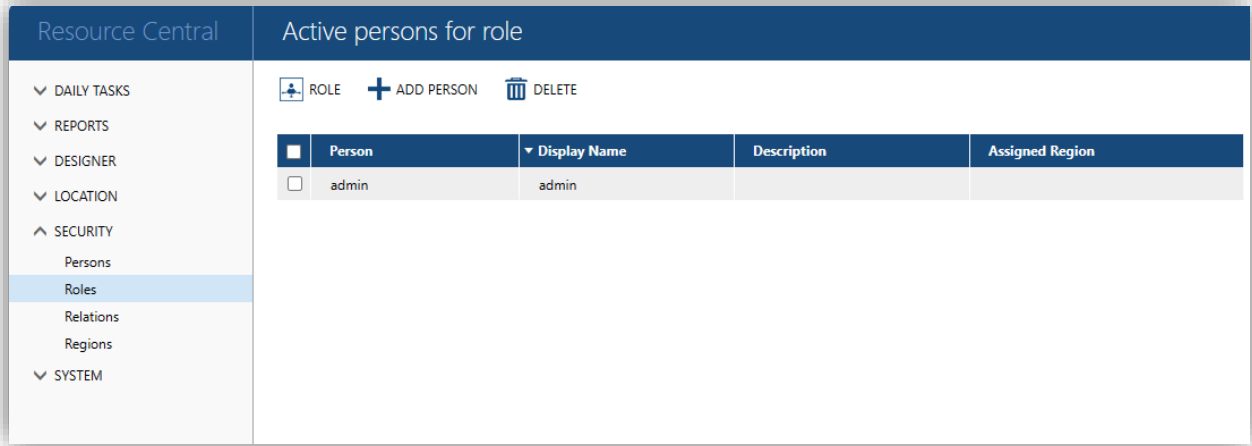

Figure 339. Roles of a Person

Toolbar Buttons	Description
Person	Takes you to the Person’s details screen
Add Role	Add a role from the list of all roles
Delete	Remove a role

Person: Assignments

This view shows the different associations for Resource and Role.

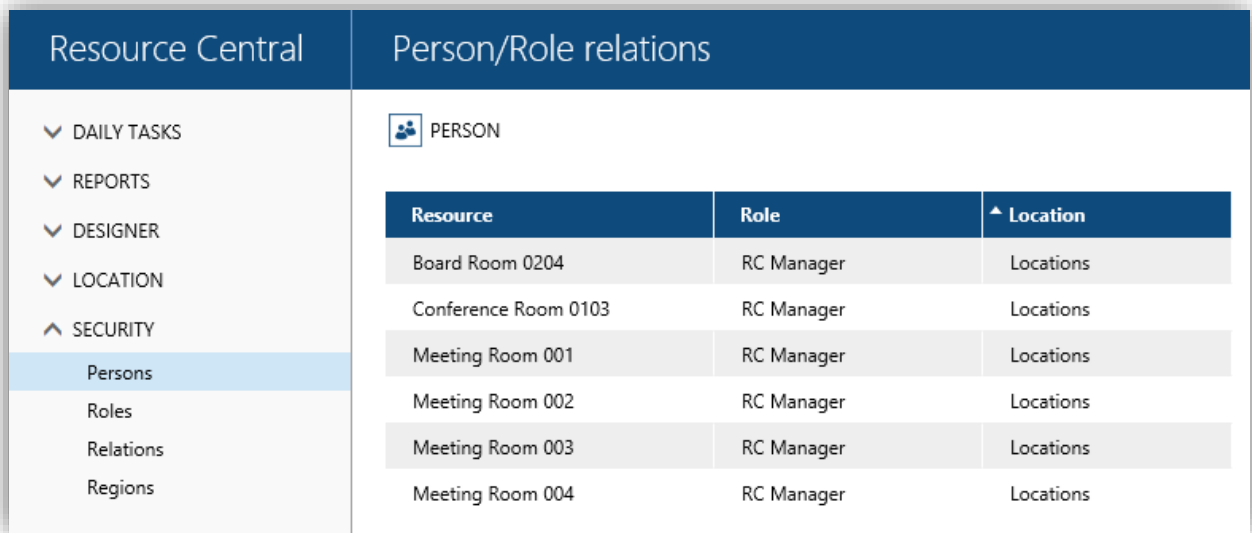

Figure 340. Assignments of a Person

Person: Set Password

This view is used to set password for the user. Remember that persons with **Blank** passwords are **not allowed** to log in the application.

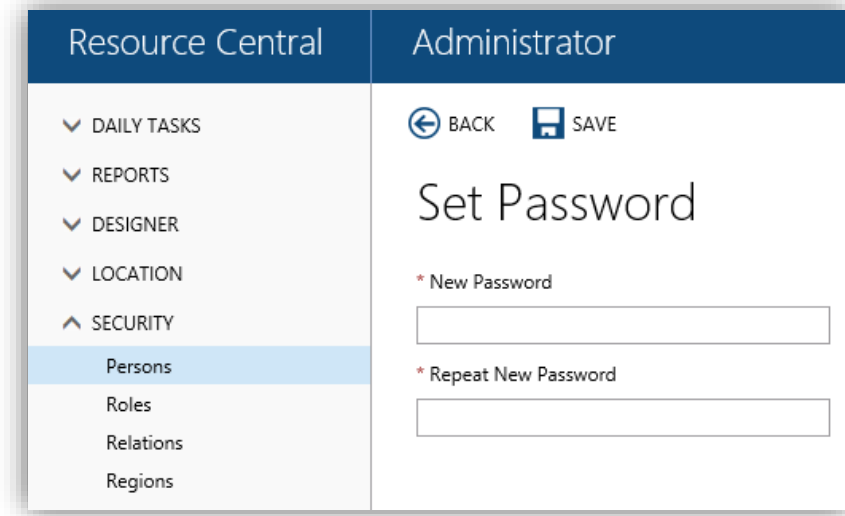

Figure 341. Set Password for a Person

Fields	Description
New Password	Enter a password for the user
Repeat New Password	Repeat the same password to confirm

Roles

This view shows all roles created in the system.

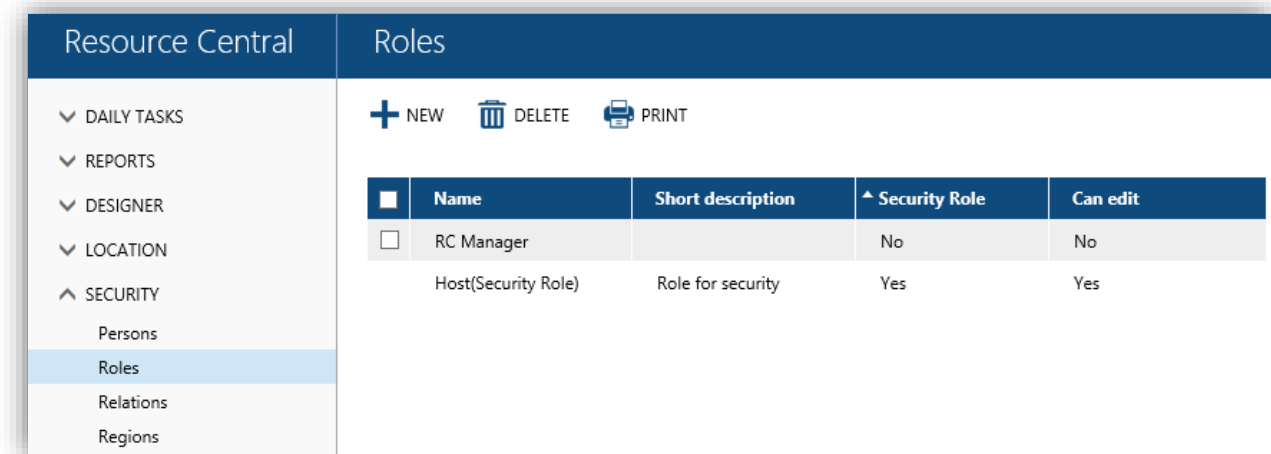

Figure 342. List of Roles

Toolbar Buttons	Description
NEW	Create a new role
DELETE	Delete the selected role
PRINT	Print the screen

Clicking one of the role records will **show details** about it.

Role details

Viewing a given role, you can **edit** and **save** it, or **maintain** person, item, and property relations. Using **[Assignments]** you can get a view of the **person/resource** relation to the role.

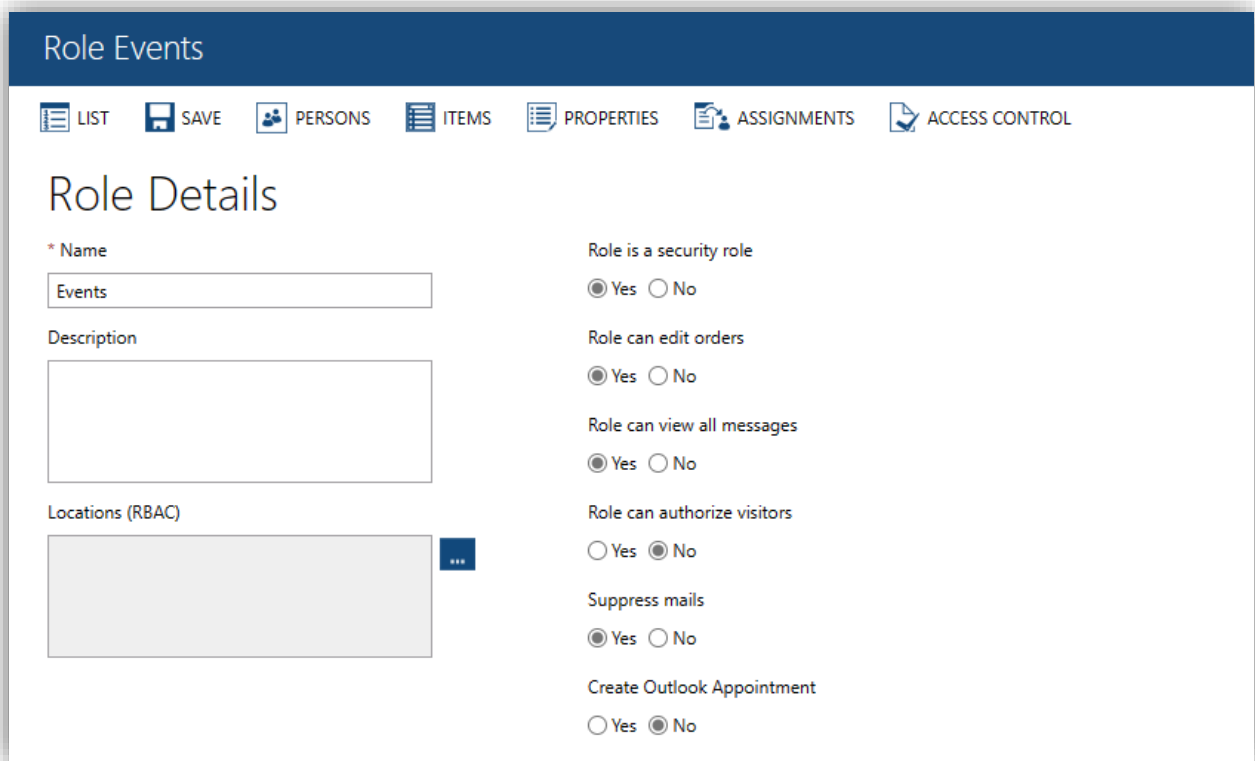

Figure 343. Details of a Role

Fields	Description
Name	A code to identify the record
Description	A short description. Max 255 characters
Location (RBAC)	Default locations that Persons of this Role are responsible for. These locations must be defined in Location tree under Locations node. NOTE: If RBAC option is NOT enabled, the Person’s locations will be used instead of the Role’s locations. If RBAC option is enabled, the Role’s locations will overwrite its Persons’ locations instead. (For more details on RBAC feature, refer to this article)
Role is a security role	When ‘Yes’ is selected, the role type is security
Role can edit orders	When replying to messages sent to the Responsible Role, this role can edit the items it is responsible for
Role can authorize visitors	When ‘Yes’ is selected, this role type can authorize registered visitors Default value of this field is “No”
Role can view all messages	This role is allowed to view all messages when logged in the application
Suppress mails	When sending messages to Persons, mails can be suppressed if this flag is set to ‘Yes’

Create Outlook Appointment	Select 'Yes' to enable creation of an appointment in service provider's calendar. You can set a reminder to be activated at a specific moment before the meeting start time
-----------------------------------	---

This is how **Create Outlook Appointment** option works in association with **Suppress mails** option:

Create Outlook Appointment	Suppress mails	How it works in RC
Yes	No	<ol style="list-style-type: none"> 1. If Organizer books a meeting with order, this meeting will be displayed in Service Provider's calendar. 2. Service Provider will be notified (by email) of any changes from the Organizer and RC backend (create/update/delete meeting) 3. In case of any changes made by the Service Provider, appointment created in the Service Provider's calendar will be updated.
Yes	Yes	Service Provider will NOT be notified (by email) of any changes from the Organizer and RC backend (create/update/delete meeting), but these changes will be updated in Service Provider's calendar.

This feature also works in collaboration with the parameter **RetryFunction.Enable**. For more details, please refer to **RC Parameter Guide**.

With this feature, each resource's order is relevant to an appointment in Service Provider's calendar.

A Service Provider can make changes to the appointment by opening it in the calendar:

- If this appointment is opened in Outlook on the web, click the **[Edit]** button:

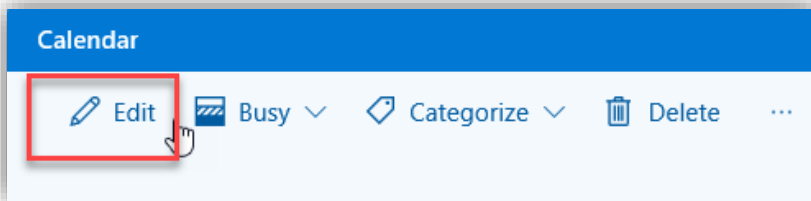

- If this appointment is opened in Outlook desktop app, the cursor is on top of the body content. Service Provider can make comments in this area (or at the bottom of the body content).

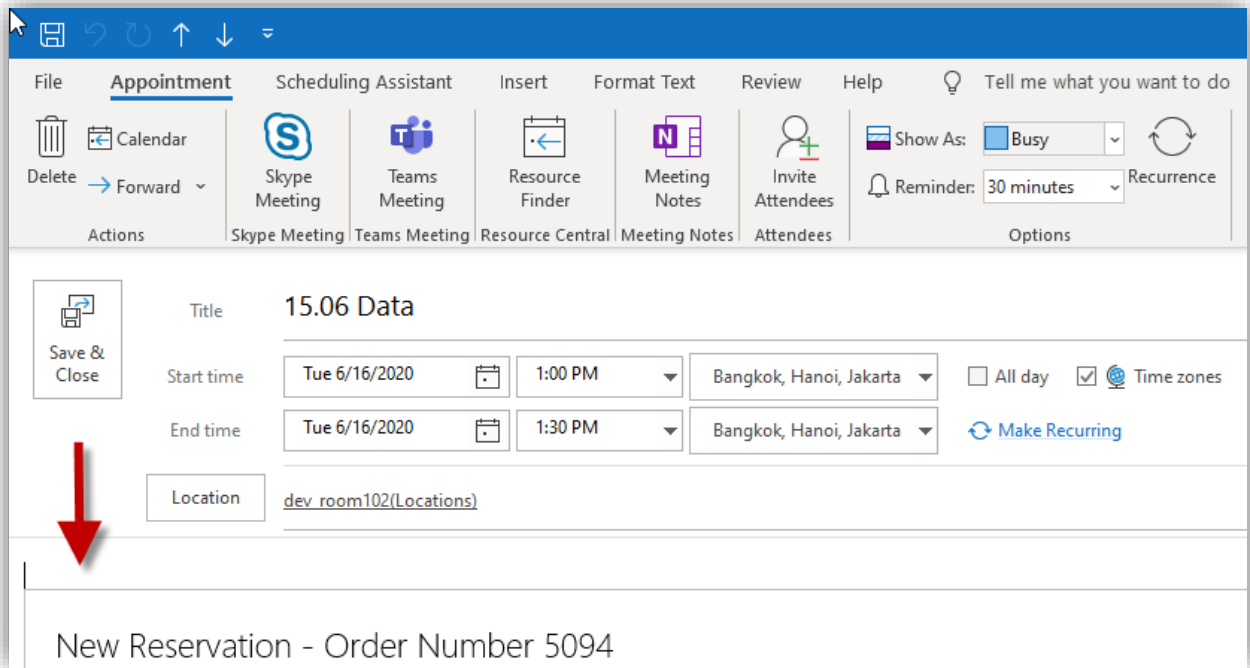

The Service provider can click on the link in the appointment to make changes to the order.

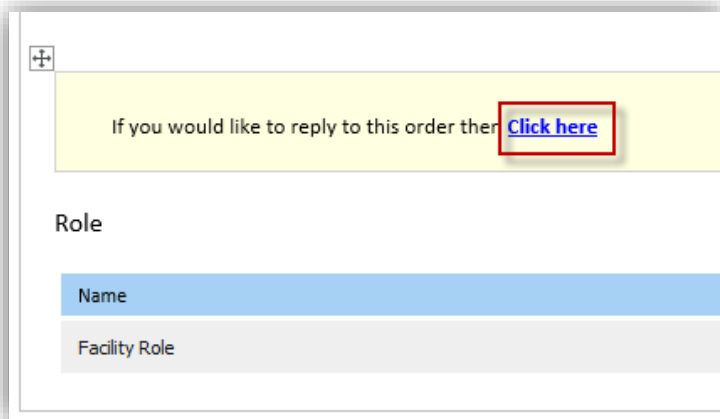

Click **[Save & Close]** to finish.

NOTE:

- Changes made to the order details (in the appointment body) by Service Provider will NOT be kept when organizer changes the order.
- Time changes made to the appointment by Service Provider are only applied to his calendar. These changes will NOT have any influence on the meeting of the Organizer.
- Comments made by Service Provider (on top or bottom) of the appointment will always be kept.

Role / Persons

This function will **run through the location tree** and assign the **person/role relation** to all resources.

This view shows the persons associated with this role. To add persons from a list for the role, select **[Add Person]**. Mark the **check box** in front of the person and select **[Delete]** to remove. Click **[Role]** to go back to **Role detail view**.



Figure 344. Persons assigned to a Role

Toolbar Buttons	Description
ROLE	Takes you back to the Role Details
ADD PERSON	Add a person from the list of all the persons
DELETE	Remove the selected persons

NOTE: If RBAC feature is enabled, the [Add Person] and [Delete] button will be removed from this toolbar. (For more details on RBAC feature, refer to this [article](#))

Role / Items

This view shows the items managed by this role. Items can be **added** from the list by using [Add Item]. Each item can either be set role type as 'Assignable' or 'Informative' (refer to [Service Provider handling service orders](#)). You can also set role type in bulk by selecting multiple items (marking the checkbox) and use [Set Role Type].

To delete item(s), select the item(s) and click [Delete]. Click [Role] to go back to **Role detail view**.

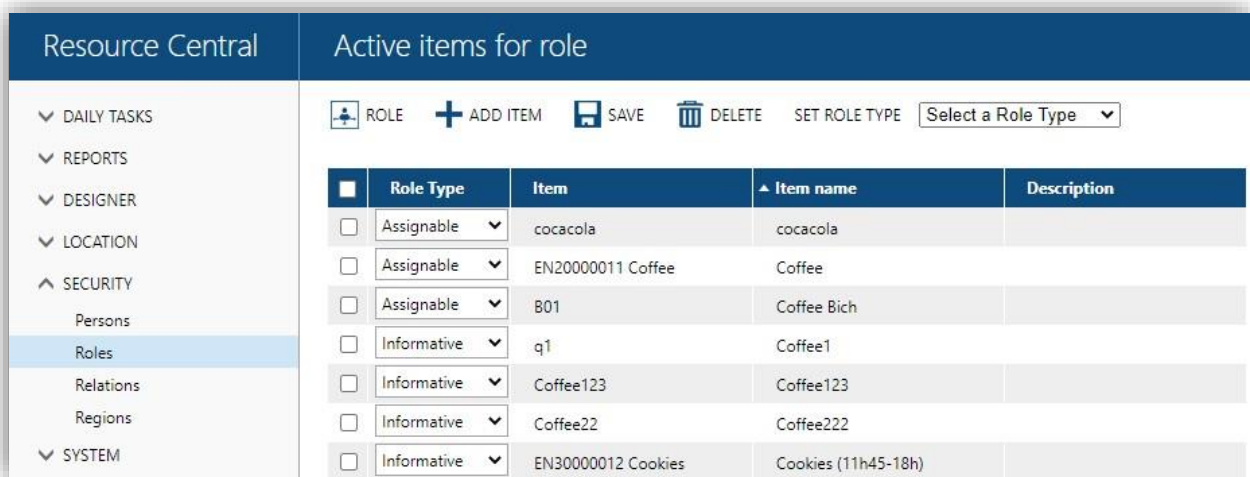

Figure 345. Items assigned to a Role

Toolbar Buttons	Description
ROLE	Take you back to the Role Details
ADD ITEM	Add an item from the list of all the items
SAVE	Save changes that have been made
DELETE	Remove the selected items
SET ROLE TYPE	Change role type in bulk when you select multiple items

Role / Properties

This view shows the properties managed by this role. Property can be added from the list by using **[Add Property]** button.

Each item can either be set role type as **'Assignable'** or **'Informative'** (refer to [Service Provider handling service orders](#)). You can also set role type in bulk by selecting multiple items (marking the checkbox) and use **[Set Role Type]**.

To delete a property, select the property and click **[Delete]**. Click **[Role]** to go back to **Role detail view**.

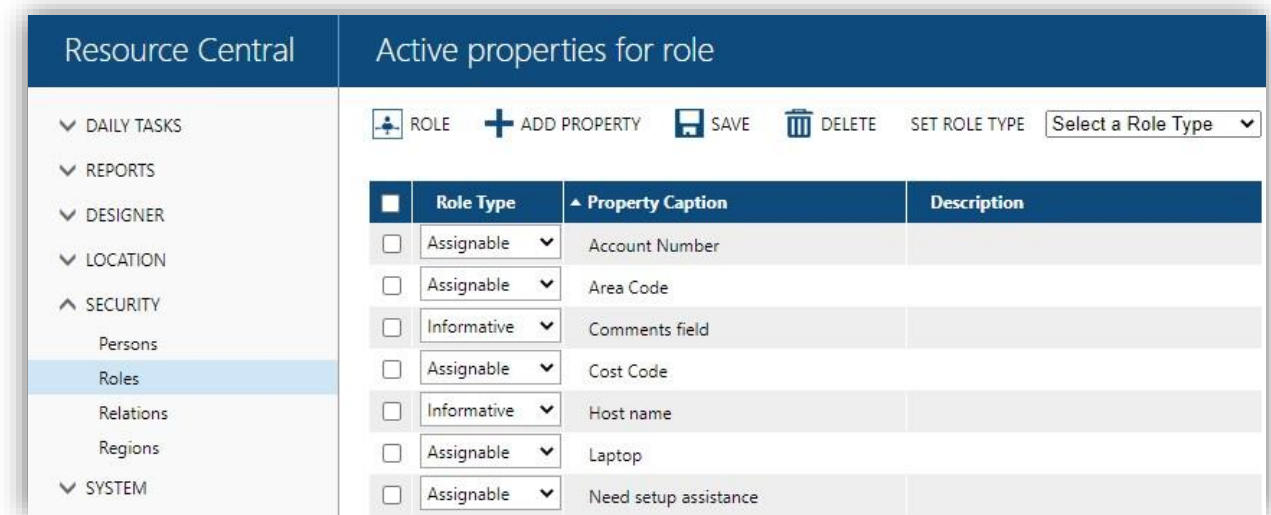

Figure 346. Properties assigned to a Role

Toolbar Buttons	Description
ROLE	Takes you back to the Role Details
ADD PROPERTY	Add a property from the list of all the properties
SAVE	Save changes that have been made
DELETE	Remove the selected properties
SET ROLE TYPE	Change role type in bulk when you select multiple properties

Role / Assignments

This view shows the different **combinations/associations** for Resource and Person.

Resource Central	Person/Role relations																							
<ul style="list-style-type: none"> ▼ DAILY TASKS ▼ REPORTS ▼ DESIGNER ▼ LOCATION ▲ SECURITY <ul style="list-style-type: none"> Persons Roles Relations Regions 	<div style="border: 1px solid #ccc; padding: 5px;">  ROLE </div> <table border="1" style="width: 100%; border-collapse: collapse; margin-top: 10px;"> <thead> <tr> <th>Resource</th> <th>Person</th> <th>Location</th> </tr> </thead> <tbody> <tr> <td>Board Room 0204</td> <td>Admin</td> <td>Locations</td> </tr> <tr> <td>Conference Room 0103</td> <td>Admin</td> <td>Locations</td> </tr> <tr> <td>Meeting Room 001</td> <td>Admin</td> <td>Locations</td> </tr> <tr> <td>Meeting Room 002</td> <td>Admin</td> <td>Locations</td> </tr> <tr> <td>Meeting Room 003</td> <td>Admin</td> <td>Locations</td> </tr> <tr> <td>Meeting Room 004</td> <td>Admin</td> <td>Locations</td> </tr> </tbody> </table>			Resource	Person	Location	Board Room 0204	Admin	Locations	Conference Room 0103	Admin	Locations	Meeting Room 001	Admin	Locations	Meeting Room 002	Admin	Locations	Meeting Room 003	Admin	Locations	Meeting Room 004	Admin	Locations
Resource	Person	Location																						
Board Room 0204	Admin	Locations																						
Conference Room 0103	Admin	Locations																						
Meeting Room 001	Admin	Locations																						
Meeting Room 002	Admin	Locations																						
Meeting Room 003	Admin	Locations																						
Meeting Room 004	Admin	Locations																						

Figure 347. Assignments of a Role

Role / Access Control





Role Security					
 SAVE  ROLE					
Node	View	Own	Add	Change	Delete
▲ Daily Tasks					
Orders	Deny	Deny	Deny	Deny	Deny
Reservations	Allow	Allow	Deny	Deny	Allow
Booking Manager	Deny	Deny	Deny	Deny	Deny
Overview	Deny	Deny	Deny	Deny	Deny
Items	Allow	Deny	Allow	Allow	Allow
Menus	Deny	Deny	Deny	Deny	Deny
Visitors	Allow	Allow	Allow	Deny	Deny
Signage	Deny	Deny	Deny	Deny	Deny
Tasks	Allow	Allow	Deny	Deny	Deny
▼ Reports					
▼ Designer					
▲ Location					
 Categories	Deny	Deny	Deny	Deny	Deny
 Locations	Deny	Deny	Deny	Deny	Deny
▲ Security					
Persons	Allow	Allow	Allow	Allow	Deny
Roles	Deny	Deny	Allow	Allow	Deny
Relations	Deny	Allow	Allow	Allow	Deny
Regions	Deny	Allow	Allow	Allow	Deny

Figure 348. Role's Access Control

This view lets you configure permissions of this role in different nodes in RC backend, including **Daily Tasks**, **Reports**, **Designer**, **Location**, and **Security**.

There are 5 permission types that you can allow or deny in each node, specifically:

- **View:** The role can see the node along with its details and items.
- **Own:**
- **Add:** The role can add new items in the node.
- **Change:** The role can edit the items in the node.
- **Delete:** The role can delete items in the node.

Relations

Matrix view of **person/role**, **property/role** and **item/role relations** is shown in Relations section, as shown below:

Roles	admin	Booking Man...	Catering	Events	Facility	HostSecurity...	Reception	SOF role	Tickets
Persons									
admin	<input checked="" type="checkbox"/>	<input type="checkbox"/>	<input checked="" type="checkbox"/>	<input checked="" type="checkbox"/>	<input checked="" type="checkbox"/>	<input type="checkbox"/>	<input type="checkbox"/>	<input type="checkbox"/>	<input type="checkbox"/>
Booking Manager	<input type="checkbox"/>	<input checked="" type="checkbox"/>	<input type="checkbox"/>	<input type="checkbox"/>	<input type="checkbox"/>	<input type="checkbox"/>	<input type="checkbox"/>	<input type="checkbox"/>	<input type="checkbox"/>
Catering	<input type="checkbox"/>	<input type="checkbox"/>	<input checked="" type="checkbox"/>	<input type="checkbox"/>	<input type="checkbox"/>	<input type="checkbox"/>	<input type="checkbox"/>	<input type="checkbox"/>	<input type="checkbox"/>
Facility	<input type="checkbox"/>	<input type="checkbox"/>	<input type="checkbox"/>	<input type="checkbox"/>	<input checked="" type="checkbox"/>	<input type="checkbox"/>	<input type="checkbox"/>	<input type="checkbox"/>	<input type="checkbox"/>
Host (Security)	<input checked="" type="checkbox"/>	<input checked="" type="checkbox"/>	<input checked="" type="checkbox"/>	<input checked="" type="checkbox"/>	<input checked="" type="checkbox"/>	<input checked="" type="checkbox"/>	<input checked="" type="checkbox"/>	<input checked="" type="checkbox"/>	<input checked="" type="checkbox"/>
Marketing	<input type="checkbox"/>	<input type="checkbox"/>	<input type="checkbox"/>	<input checked="" type="checkbox"/>	<input type="checkbox"/>	<input type="checkbox"/>	<input type="checkbox"/>	<input type="checkbox"/>	<input type="checkbox"/>
Reception	<input type="checkbox"/>	<input type="checkbox"/>	<input type="checkbox"/>	<input type="checkbox"/>	<input type="checkbox"/>	<input type="checkbox"/>	<input checked="" type="checkbox"/>	<input type="checkbox"/>	<input type="checkbox"/>
SOF agent	<input type="checkbox"/>	<input type="checkbox"/>	<input checked="" type="checkbox"/>	<input type="checkbox"/>	<input type="checkbox"/>	<input type="checkbox"/>	<input type="checkbox"/>	<input checked="" type="checkbox"/>	<input type="checkbox"/>
Items									
Properties									
abenraaDepartment	<input type="checkbox"/>	<input type="checkbox"/>	<input type="checkbox"/>	<input type="checkbox"/>	<input type="checkbox"/>	<input type="checkbox"/>	<input type="checkbox"/>	<input type="checkbox"/>	<input type="checkbox"/>
ArrivalDate	<input type="checkbox"/>	<input type="checkbox"/>	<input type="checkbox"/>	<input type="checkbox"/>	<input type="checkbox"/>	<input type="checkbox"/>	<input checked="" type="checkbox"/>	<input type="checkbox"/>	<input type="checkbox"/>
Artskonto	<input type="checkbox"/>	<input checked="" type="checkbox"/>	<input type="checkbox"/>	<input type="checkbox"/>	<input type="checkbox"/>	<input type="checkbox"/>	<input type="checkbox"/>	<input type="checkbox"/>	<input type="checkbox"/>
Barcode	<input type="checkbox"/>	<input type="checkbox"/>	<input type="checkbox"/>	<input type="checkbox"/>	<input type="checkbox"/>	<input type="checkbox"/>	<input type="checkbox"/>	<input type="checkbox"/>	<input type="checkbox"/>
Betaler	<input type="checkbox"/>	<input checked="" type="checkbox"/>	<input type="checkbox"/>	<input type="checkbox"/>	<input type="checkbox"/>	<input type="checkbox"/>	<input type="checkbox"/>	<input type="checkbox"/>	<input type="checkbox"/>
betalingsansvarlig	<input type="checkbox"/>	<input type="checkbox"/>	<input type="checkbox"/>	<input type="checkbox"/>	<input type="checkbox"/>	<input type="checkbox"/>	<input type="checkbox"/>	<input type="checkbox"/>	<input type="checkbox"/>
Brochure Ariadne - number	<input type="checkbox"/>	<input type="checkbox"/>	<input type="checkbox"/>	<input checked="" type="checkbox"/>	<input type="checkbox"/>	<input type="checkbox"/>	<input type="checkbox"/>	<input type="checkbox"/>	<input type="checkbox"/>
Brochure Ariadne language	<input type="checkbox"/>	<input type="checkbox"/>	<input type="checkbox"/>	<input checked="" type="checkbox"/>	<input type="checkbox"/>	<input type="checkbox"/>	<input type="checkbox"/>	<input type="checkbox"/>	<input type="checkbox"/>
Brochure DSS - number	<input type="checkbox"/>	<input type="checkbox"/>	<input type="checkbox"/>	<input checked="" type="checkbox"/>	<input type="checkbox"/>	<input type="checkbox"/>	<input type="checkbox"/>	<input type="checkbox"/>	<input type="checkbox"/>
Brochure DSS language	<input type="checkbox"/>	<input type="checkbox"/>	<input type="checkbox"/>	<input checked="" type="checkbox"/>	<input type="checkbox"/>	<input type="checkbox"/>	<input type="checkbox"/>	<input type="checkbox"/>	<input type="checkbox"/>
Brochure EC - number	<input type="checkbox"/>	<input type="checkbox"/>	<input type="checkbox"/>	<input checked="" type="checkbox"/>	<input type="checkbox"/>	<input type="checkbox"/>	<input type="checkbox"/>	<input type="checkbox"/>	<input type="checkbox"/>
Brochure EC language	<input type="checkbox"/>	<input type="checkbox"/>	<input type="checkbox"/>	<input checked="" type="checkbox"/>	<input type="checkbox"/>	<input type="checkbox"/>	<input type="checkbox"/>	<input type="checkbox"/>	<input type="checkbox"/>
Brochure MFC - number	<input type="checkbox"/>	<input type="checkbox"/>	<input type="checkbox"/>	<input checked="" type="checkbox"/>	<input type="checkbox"/>	<input type="checkbox"/>	<input type="checkbox"/>	<input type="checkbox"/>	<input type="checkbox"/>

Figure 349. Relations

Toolbar Buttons	Description
PRINT	Print the screen
SAVE	Saves the changes that have been made
FILTER	Displays the filter controls
ASSIGNMENTS	Displays all the assignments of the application

Using this view you can **view** and **edit** the **role relations** across several **persons**, **items** and **properties** simultaneously.

Relations / Filter

Using Filter, the results can be refined by mentioning **specified criteria** as shown below.

Relations

Filters

Role	Person	Item	Property
From	From	From	From
A	A	A	A
To	To	To	To

Apply Filter

Clear Filter

Figure 350. Filter applied on the Relations' screen

Specify criteria and then click **[Apply filter]**, the Matrix view of **person/ role, property/role** and **item/role relations** changes accordingly.

Relations / Assignments

This view shows the **relations between the different resources, roles and persons.**

Person/Role relations

RELATIONS

Resource	Role	Person	Location	Region
Board Room 0204	Host(Security Role)	HOST	Locations	
Board Room 0204	Host(Security Role)		Locations	
Board Room 0204	RC Manager	Admin	Locations	
Conference Room 0103	Host(Security Role)	HOST	Locations	
Conference Room 0103	Host(Security Role)		Locations	
Conference Room 0103	RC Manager	Admin	Locations	
Meeting Room 001	Host(Security Role)	HOST	Locations	
Meeting Room 001	Host(Security Role)		Locations	
Meeting Room 001	RC Manager	Admin	Locations	
Meeting Room 002	Host(Security Role)	HOST	Locations	

First Page Previous 1 / 2 Next Last Page Go

Figure 351. All the Assignments in the system

Regions

This task is only available when the Share Order 1.0 is enabled. In order to enable it, please refer [to this section](#).

A list of regions created in the system is shown at “**Regions**” section:

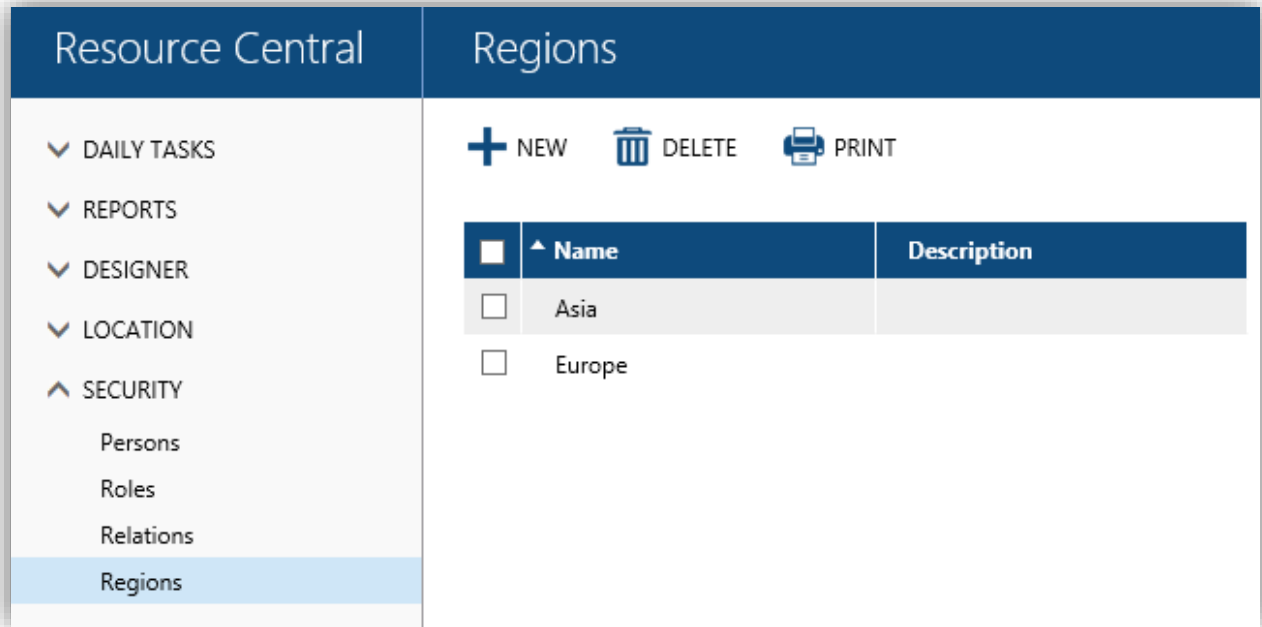

Figure 352. List of regions

Toolbar Buttons	Description
NEW	Create a new region
DELETE	Delete a selected region
PRINT	Print the screen

Clicking a region will show its details.

Region details

Viewing a given region, you can **edit** and **save** it.

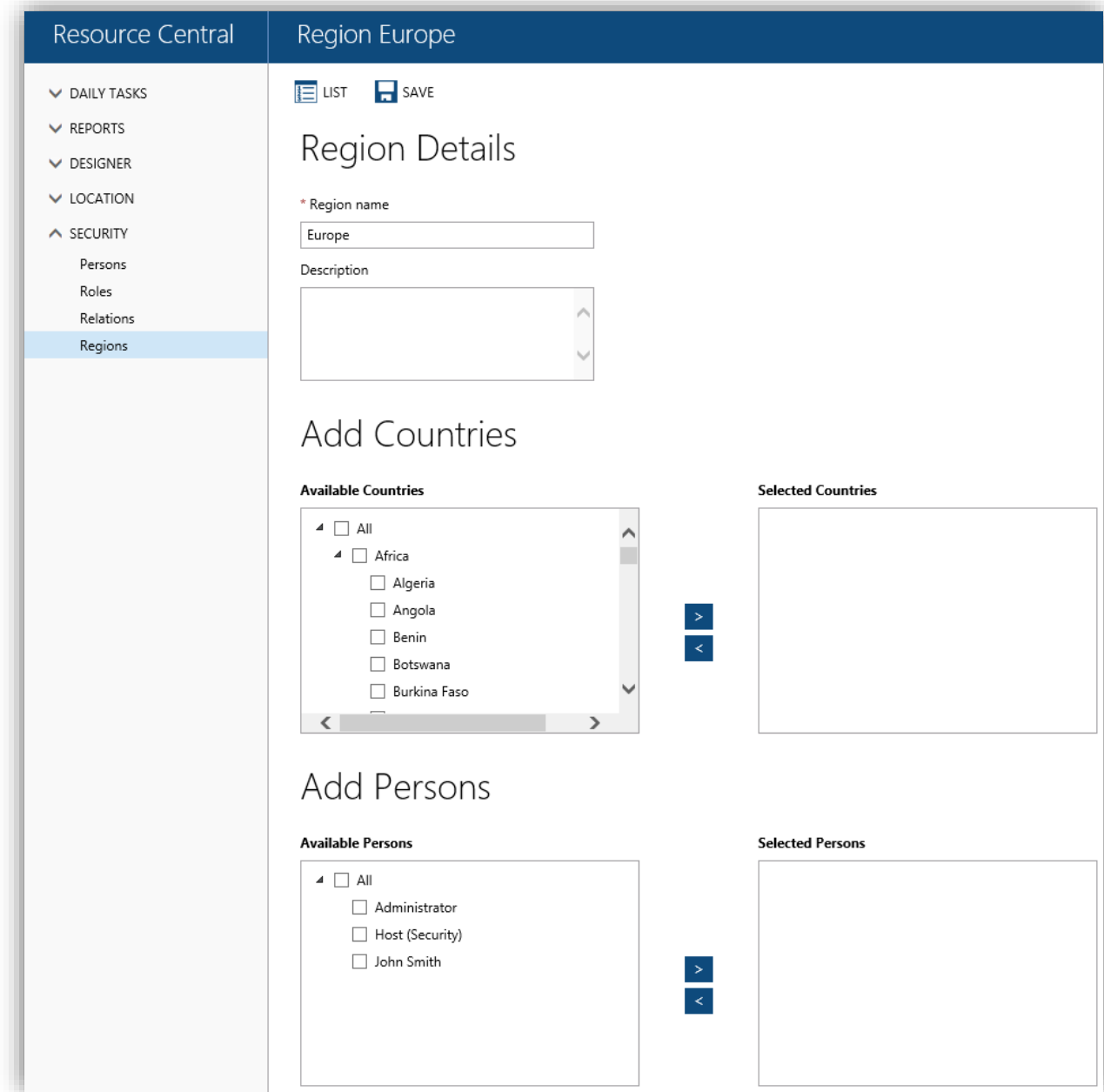

Figure 353. Region details

You can add a country into the region by selecting country name in the “**Available countries**” list and using arrow button to move it to “**Selected countries**” list.

Adding a country is not mandatory. When no countries are added to a region, the organizer will always be prompted for a region when he is using a shared order form.

You can also add a person to this region by selecting from “**Available persons**” list and moving it to “**Selected persons**” list.

NOTE: If a person is selected for a region, it cannot be selected for any other region.

System

This section is divided into the following areas:

- [Parameters](#)
- [Manifest Files](#)
- [Client Apps](#)
- [SMS Configuration](#)
- [Languages](#)
- [Calendar](#)
- [Mail log](#)
- [SQL](#)
- [Database Cleaner](#)
- [License](#)
- [Authentication](#)
- [Resource Data Synch](#)
- [GDPR](#)
- [Information](#)

Parameters

Parameters are used for system configuration. Every parameter has its own functionality.

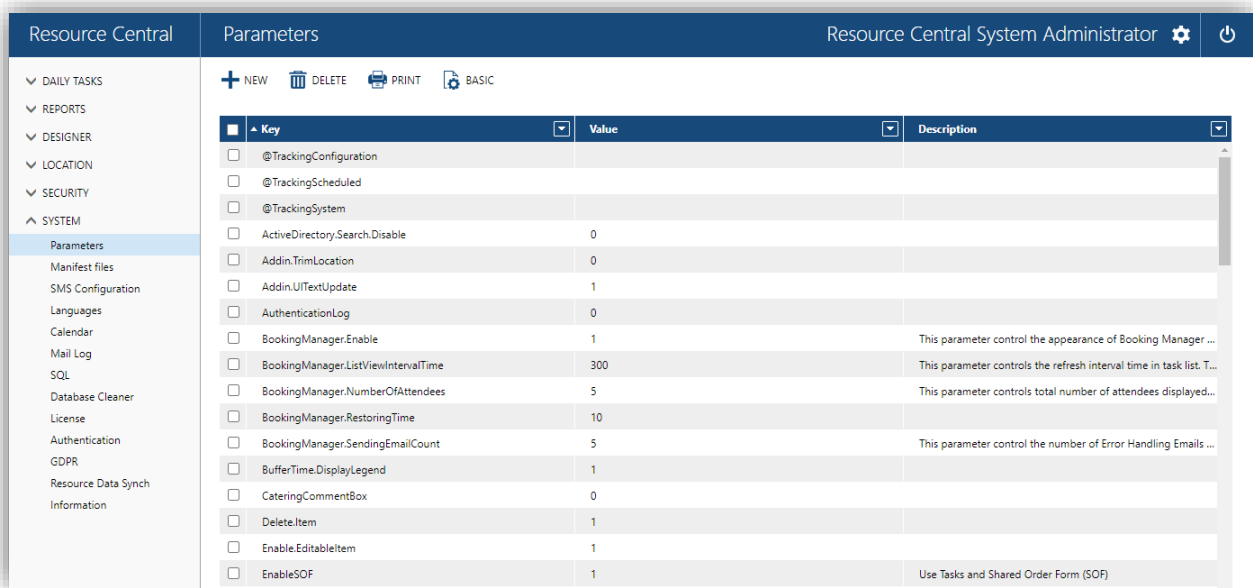

Figure 354. Parameters - List

Toolbar buttons	Descriptions
NEW	Clicking [New] button will display the detail view of Parameters with blank values in all the fields given. User can create a new parameter from there.
DELETE	Clicking [Delete] button after selecting a parameter will display a delete confirmation message. On selecting OK, the parameter whose check box is checked/clicked/selected is deleted.
PRINT	Clicking [Print] button will show Print dialog window.
BASIC	Clicking [Basic] button will show the Basic Parameters Details.

There are two types of parameters as described below.

Advanced Parameters

When the application is accessed for the first time, there are some core parameters created automatically by system with the corresponding default values:

Parameters	Value
FavouriteList.NoOfMostUsedResources	10
Addin.TrimLocation	0
Visitor.ArrivalAlert	1
SendEmailCheckbox	1
ResourceFinder.ShowSelectedResource	1
RC.WeekStartDay	0
ResourceFinder.FavouriteList	1
ResourceFinder.PriorBooking	0
ResourceFinder.From	7
ResourceFinder.To	17
ResourceFinder.PageSize	40
ResourceFinder.MsgForNoOrder	0
ResourceFinder.EnableLocationCheckbox	0
ResourceFinder.PriorBookingTime	10
OrderForm.SendOrderAlignment	1
MyMeeting.DirectAccess	0
Delete.Item	1
Item.Price	1
WeeklyHolidays	6, 0
ReservationEmail.ShowDetail	0
ResourceFinder.ReservationList.ShowCapacityColumn	1
Filter.AndOr	0
Show.CheckBoxAvailableResources	1
StandardReport.IncludeTentativeMeeting	1
ExtraServicesReport.PropertyList	-1
WeekPlanner.TimePeriod	60
Addin.UITextUpdate	1
BookingManager.RestoringTime	10
BookingManager.Enable	0
BookingManager.NumberOfAttendees	5
BookingManager.ListViewIntervalTime	300
BookingManager.SendingEmailCount	5

However, the user (system) can create other parameters to customize the system as desirable. The list of these parameters and their functionality detail is given in the **Parameters Guide**.

Basic Parameters

These kinds of parameters are automatically created by the system when RC is installed. However, user (system) can change their values afterward. (See **Resource Central Manager → General → Parameters → Basic** section for details).

Parameters – Details

Clicking on any parameter will display its details. The detail view of the Parameters shows the values for each parameter field. User can **edit & save** the parameter.

Figure 355. Details of a Parameter

Field	Description
Key	Name of the parameter, used for unique identification of the parameter.
Value	Value of the parameter.
Description	Short description of the parameter.

Toolbar button	Description
Save	Changes in the Input fields are saved
List	Displays the list of all Parameters

Parameters - Basic

Basic Parameters screen can be accessed by clicking 'Basic' button on the toolbar or by accessing the initial setup screen once the application is installed. This screen shows the list of basic parameters and their values. However, user can **change** the values, **save** them, and **re-configure** the application according to new values as shown in the figure below:

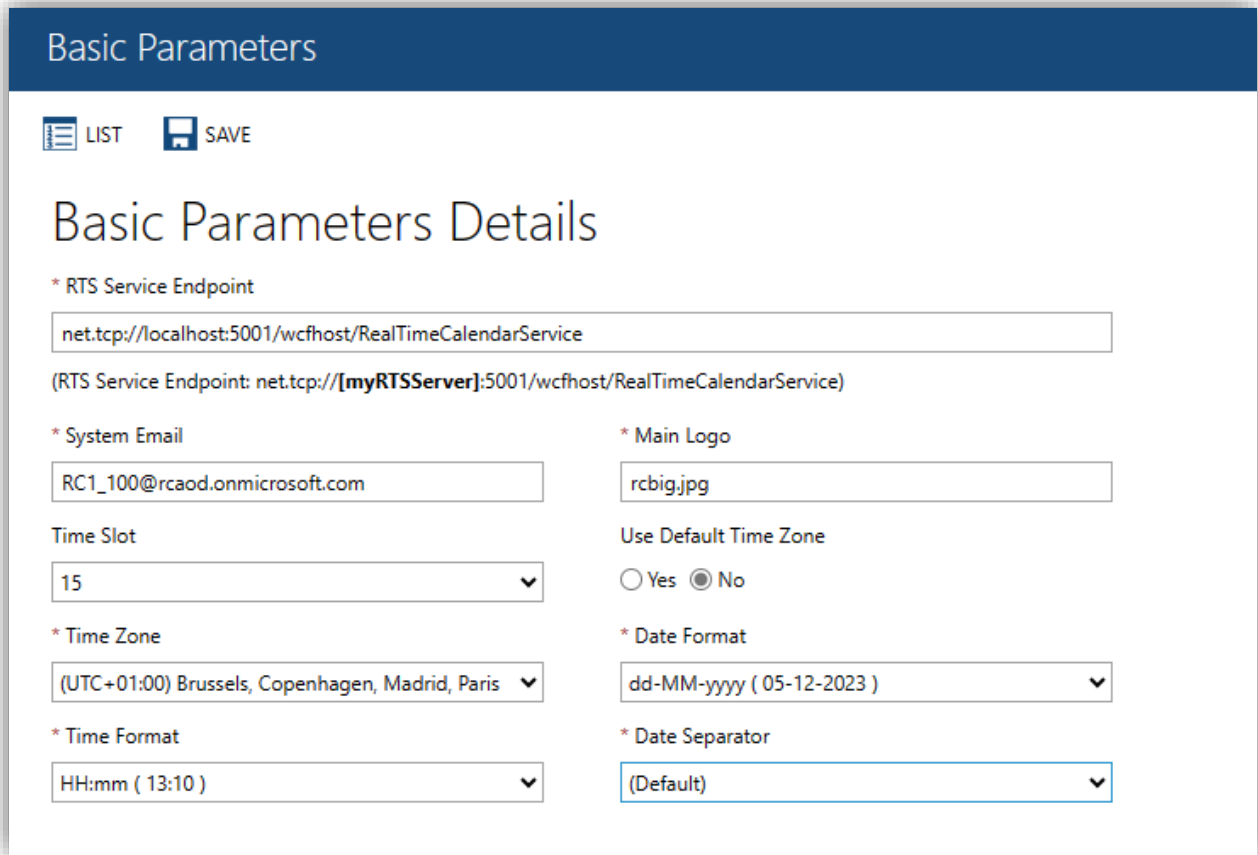

Figure 356. Basic parameters

Field	Description
RTS Service Endpoint	This parameter establishes the EndPoint address of RTS Calendar Service through which RC calls RTS WCF to interact with Exchange and Active Directory. Value of this parameter is the path to the end point address.
System Email	Email address used by RC when sending out confirmation emails from Virtual Resources, Shared Orders Forms, Booking Manager, RC Reminder, Visitor, KIOSK or Signage.
Time Slot	This is to choose the time interval that you want the application to use. The effect of its value could be seen at ResourceFinder and Resource's details screen. + Time Slot = 60: Number of minutes > 30: Rounded up (e.g.: 04:31 → 05:00) Number of minutes < 30: Rounded down (e.g.: 04:29 → 04:00) Number of minutes = 30: Hour is even number: Rounded down (e.g.: 02:30 → 02:00) Hour is odd number: Rounded up (e.g.: 01:30 → 02:00)

	<p>+ Time Slot = 30: Number of minutes > 15: Rounded up (e.g.: 04:16 → 04:30) Number of minutes ≤ 15: Rounded down (e.g.: 04:14 or 04:15 → 04:00)</p> <p>+ Time Slot = 15: Number of minutes > 7: Rounded up (e.g.: 04:10 → 04:15) Number of minutes ≤ 7: Rounded down (e.g.: 04:06 or 04:07 → 04:00)</p>
Time Zone	Time Zone value for the entire application. All the date/time values being used across the RC application will be displayed/manipulated according to the selected time zone value.
Time Format	Time format to be followed across all the emails in Order Processing in the RC Application.
Main Logo	This is name of the image file, which will be displayed on front page of Resource Central web application. The file must exist in the 'Images' folder of the application's virtual directory on Web server.
Use Default Time Zone	<p>If Yes, selected Time Zone value will be applicable to entire application, ignoring the individual Time Zone values of Person, Resource and/or Client machine (if applicable)</p> <p>By default, the selected value is "Yes"</p> <p>If the value is "No", selected Time Zone value will not be applicable on entire application. In this case, the individual Time Zone values of Person, Resource and/or Client machine will be applicable.</p>
Date Format	Date format to be followed across all the emails in Order Processing in the RC Application.
Date Separator	Date Separator to be used in the dates across all the emails in Order Processing in the RC Application.
Toolbar button	Description
SAVE	Saves the values entered by the user in the fields in database. All the fields are mandatory.
LIST	Takes you to Parameters screen.

Manifest Files

In this section, you can download the manifest used for the Outlook Add-in or for Teams deployment. Click the download link to get the file.

You can download the manifest files and save them to your computer. For how to use these manifest files for Outlook Add-in or Microsoft Teams, please refer to ***RC Outlook Add-in - Installation Guide*** or ***Microsoft Teams Integration Guide***.

The section will be available as long as the new Outlook Add-in has not been installed.

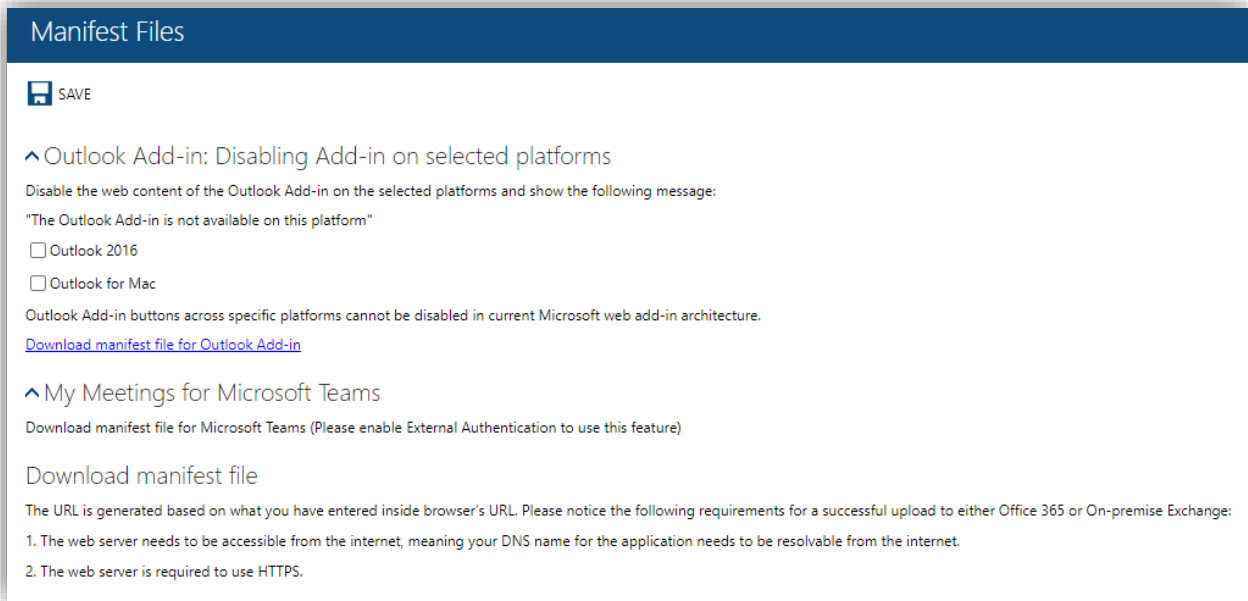

Figure 357. Manifest files

You can disable the Outlook Add-in on some platforms if you only want it enabled on Outlook for Web. Select the platform by checking on the checkbox next to it. Then click **[Save]** to finish.

Client Apps

Client Apps replaces the Manifest Files section when you have Client Apps installed on the RC server.

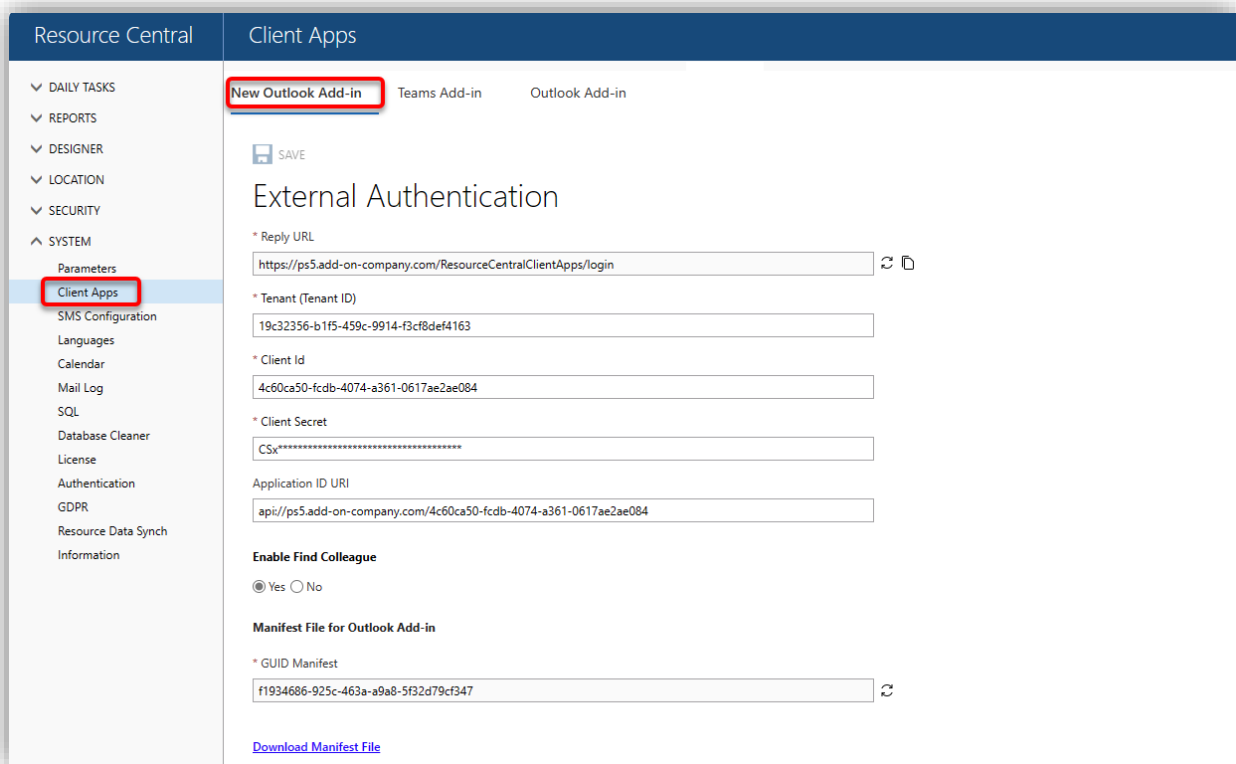

Figure 358. Client Apps

For information about how to install Client Apps to RC backend, please refer to **RC Client Apps Installation Guide**. To configure “External Authentication” for Client Apps, refer to **KnowledgeBase Article - How to configure Entra ID Application for the New Outlook Add-in** on our support site. You can then download the manifest file to your computer and use it for Outlook Add-in deployment.

SMS Configuration

In this section, you can configure the function of sending SMS to organizers and assistant organizers to inform them whenever a visitor checks in.

SMS Configuration

Enable configuration
 Yes No

Message

Please be informed that [VISITOR_NAMES] has arrived.

Where?
 Location name: [LOCATION]

Kiosk name: [KIOSK_NAME]

When?
 Arrival Time: [ARRIVAL_TIME]

For?
 Meeting subject: [MEETING_SUBJECT]

* Provider name
 Computopic SMS

Computopic SMS Configuration

URL https://smssys.dk/sms	Short code
User name	Category
Password	Category description
Sender alias	Charset

Figure 359. SMS Configuration

Select Yes to enable all other fields to be edited.

The message content can be composed under the Message heading. If you want the data to be automatically transmitted to the message, the square brackets, and the content inside them must remain.

The provider can be selected from the drop-down list. Each provider will open up a section for configuration. Fill all necessary details and click **[Save]** to finish.

Refer to [KB0244 - How to configure SMS sending using Computopic account](#) for instructions on how to configure SMS sending per vendor.

Toolbar button	Description
SAVE	Saves the values entered by the user in the fields
TEST	Test the input data

Languages

In order for you to configure the language used in the system, this section is created.

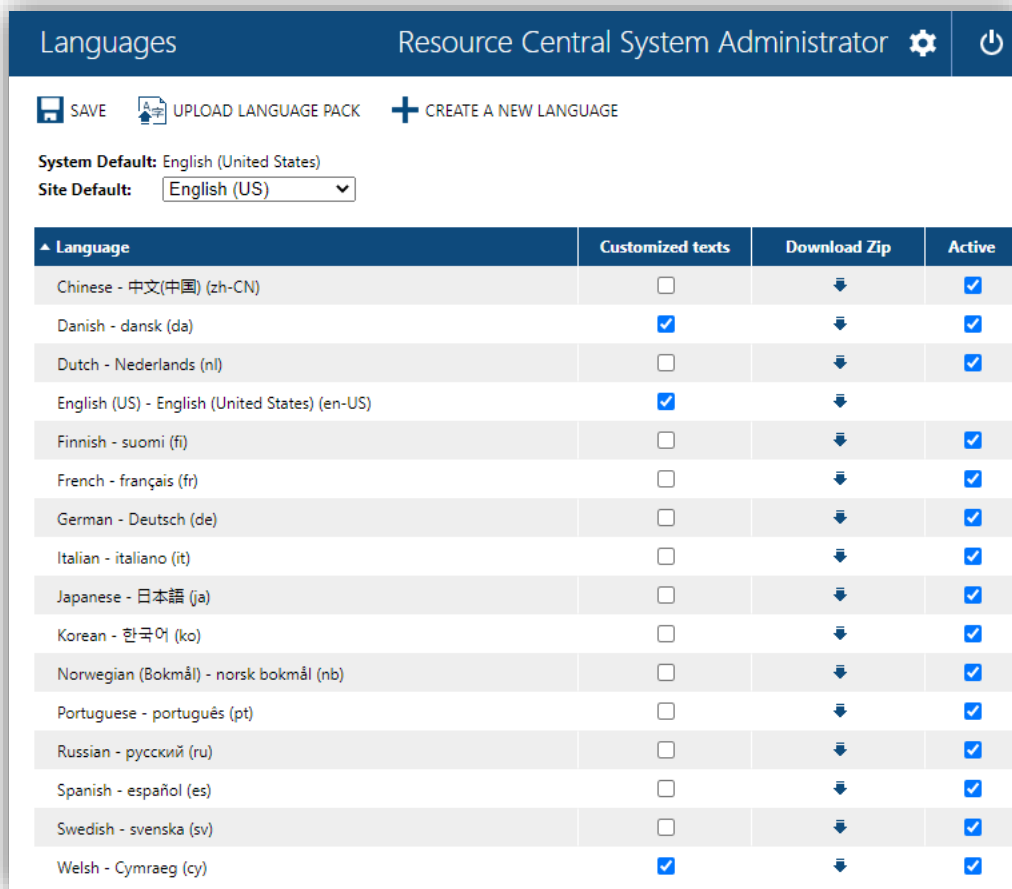

Figure 360. Languages section

This language page lists all languages installed in the system:

- Each language has a **Download Zip** link that, if clicked, will initiate the download of a Language Package. By extracting this zip file, you can have a PO file listing all localized texts of a language. You can make changes to it if you want, then upload to the system.
- Each language has a checkbox (in **Active** column) that if unchecked the language will be disabled (e.g., in the Language selection of **ResourceFinder**).

NOTE:

- All lists of languages in RC system reflect the list of languages in this page.
- When a language is disabled and user is using that language, the language specified in “Site Default” field will be used.

Upload Language Package

If you want to install a new language using a Language Pack that was provided by AOP or update the translation of an instance of RC (e.g., the package contains the new translations you made to the PO file), click [**Upload Language Pack**] button on the toolbar, the following panel appears:

Figure 361. Upload a new language package

Click [**Submit**] button to upload the package. After that, the language package you have submitted will be applied in the entire system.

Create a new language

If you want to request AOP to support a new language or to create a localized version of a language, click [**Create New Language**] button on the toolbar, the following panel appears:

Figure 362. Create a new language

For example: You want to create **British-English** version based on the **American-English** version (en-US) in RC, make your selection as shown in the figure below:

Figure 363. Create a new language

After clicking [**Save**] button, the new language you want to create shows up in the language list:

Language	Customized texts	Download Zip	Active
Chinese - 中文(中国) (zh-CN)	<input type="checkbox"/>	↓	<input checked="" type="checkbox"/>
Danish - dansk (da)	<input type="checkbox"/>	↓	<input checked="" type="checkbox"/>
Dutch - Nederlands (nl)	<input type="checkbox"/>	↓	<input checked="" type="checkbox"/>
English (United Kingdom) - English (United Kingdom) (en-GB)	<input type="checkbox"/>	↓	<input checked="" type="checkbox"/>
English (US) - English (United States) (en-US)	<input type="checkbox"/>	↓	<input type="checkbox"/>
Finnish - suomi (fi)	<input type="checkbox"/>	↓	<input checked="" type="checkbox"/>
French - français (fr)	<input type="checkbox"/>	↓	<input checked="" type="checkbox"/>
German - Deutsch (de)	<input type="checkbox"/>	↓	<input checked="" type="checkbox"/>

Figure 364. List of language

If you want to perform **custom localization**, please refer to this [Appendix](#).

Calendar

In order to extend the Resource Central Calendar functionality, the manager can define a custom calendar which behaves as the normal calendar and can be associated with locations and persons to use it throughout the application or customize the already created calendar.

Its main purpose is to define holidays in the calendar on which only **Reservation** can be placed but **Order** will not be allowed. If the user tries to place the order, system will display the message on clicking “Send Order” that ‘the order cannot be placed on a holiday’:

Figure 365. Order cannot be placed on holiday message

'Calendars' screen lists all calendars. You can add/update/delete a calendar from this view.

By default, a calendar entry '**Default Calendar**' would always be created, and it cannot be deleted. However, it can be updated. By default, it is associated with all existing/new locations in the system.

If you delete a calendar, all of its corresponding associations with Location(s) will be automatically removed. In that case the calendar whose 'Is default' value is set to 'Yes' will be associated with all locations and their child locations where the deleted calendar was associated.

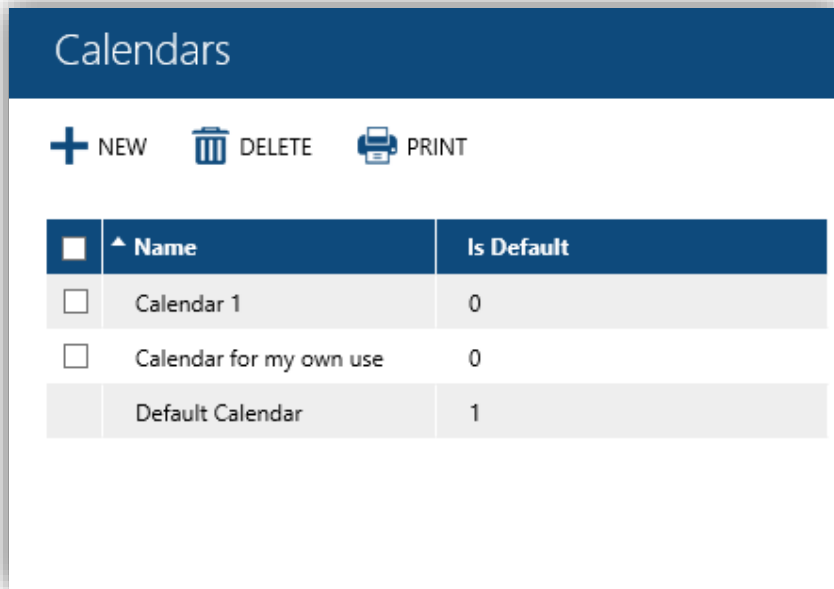

Figure 366. List of Calendars

Toolbar Buttons	Description
NEW	Create a New Calendar
DELETE	Deletes a selected Calendar
PRINT	Print the screen

Clicking one of the calendars will show its details.

Calendar Detail

From the calendar detail view, you can edit and save the record, enter/edit name of the calendar and can make this calendar default by selecting 'Yes' from the dropdown against 'Is Default'. If this is the case, then the 'Default Calendar' will no longer be default and its 'Is Default' value will set to 'No' automatically because at a time only one calendar can be set as default.

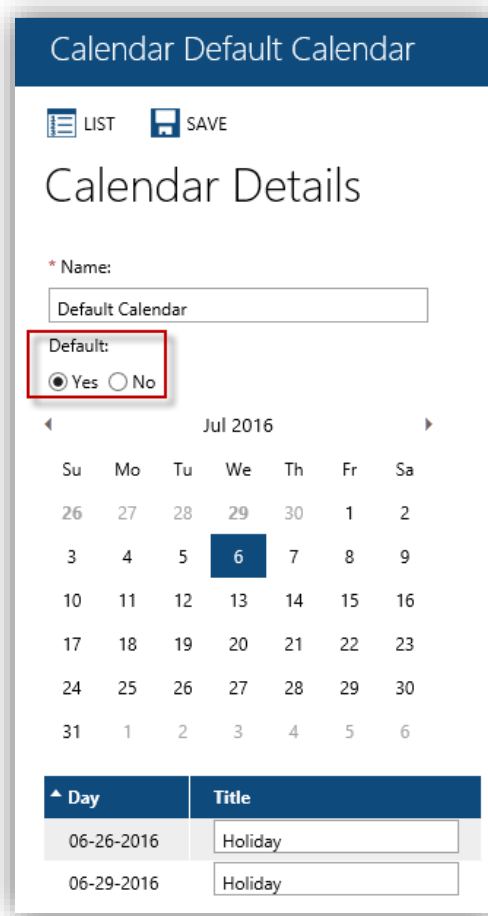

Figure 367. Choose Default Calendar Option

Field	Description
Name	A friendly name for the Calendar. (Mandatory field)
Is Default	Select 'Yes' if you want to make this calendar as default (at a time only one calendar can be default).
Day	Selected date as a holiday by the user.
Title	Title of the holiday (This will be displayed as tooltip on the respective defined holidays of the calendar across the RC application)

You have the option to define the Normal Working Days/Holidays. You can specify holidays at whatever date you want to. This can be achieved with a single click on a date, and you can give a title for that holiday and then click Save. On subsequent single clicks, you can select/de-select a date i.e., mark it as a holiday/working day accordingly.

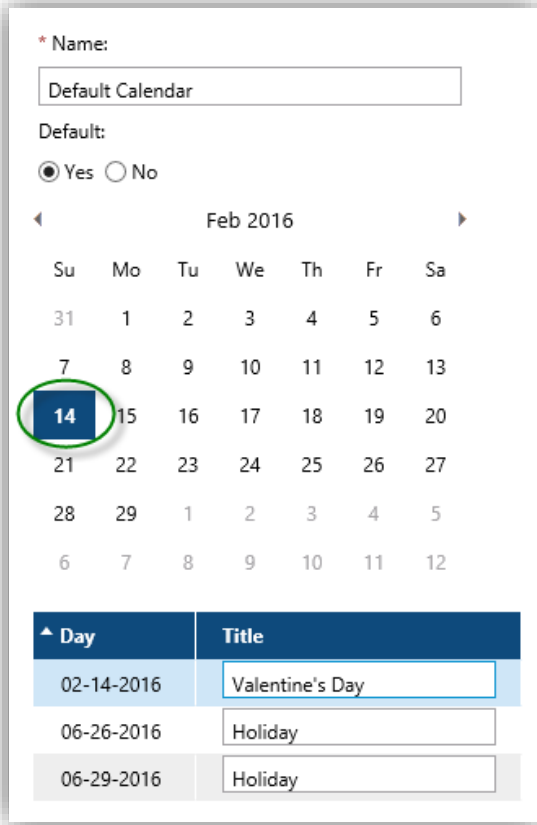

Figure 368. Choose Holiday

Holiday is a day where reservation can be placed but order cannot be.

User is provided with monthly view of the calendar only with the current day and month selected. When user clicks on the month and year of the calendar, a list of months in that year is displayed where he can select the month and its calendar is shown. Same is true for the year. When the user clicks on the year, a list of years is displayed, and the user can select the year.

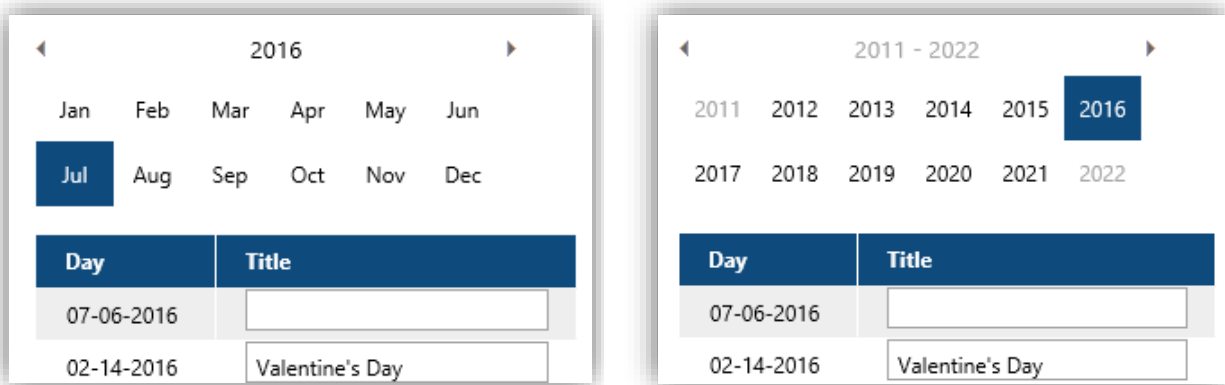

Figure 369. Details of a Calendar

SAVE	Saves the data in the Input fields
LIST	Takes you to the list of Calendars

Calendar Location Association

When the application is installed for the first time, a 'Default Calendar' is already created.

While defining a new location manually or modifying the properties of an already created location from Locations screen, you will have to specify the Calendar in Location properties. Calendar is a drop down, with the calendar whose 'Is default' value is set to 'Yes' selected by default. You have the option to apply the properties of this calendar to the location and all of its child location(s) as well.

If you have explicitly associated any other calendar at a child location, then the impact of the Parent Location calendar will be ignored.

As a calendar has been associated with a location, it will be directly bound with all of the resource(s) at that location.

Below is the Properties window of location where calendar dropdown is available for calendar selection.

Figure 370. Location properties

Calendar Person Association

In **Security → Persons** screen, Location field is mandatory. At least one location field must be filled. The selected location's calendar properties will be associated with the person and that calendar will be applied throughout the application who logs in the system.

Calendar Order Association

You will not be allowed to place an order over such a date that has already been defined as a Holiday in that particular associated Location Calendar (even From Email link, My Meetings, RC Admin → Reservations).

However, you are allowed to place/change/delete reservations on those dates. If such a reservation for which an order has been already placed is changed such that its new date is a Holiday, then the organizer will not be able to change the details of that order from any of the interfaces (Email link, My Meetings, RC Admin → Orders, and Reservations).

Mail Log

You can view **log** of all **mails** routed through Resource Central. You can **view contents** of the **mail** by clicking on it. You can also **reply** to the **mail** and initiate any change in the workflow.

Filtering of mails can be done based on calendar. The days displayed bold in the calendar are the ones with mails sent on that day. Mail log contains mails of New Reservation, Changed Reservation, New Order, Changed Order, Accept Order, Decline Order, Visitor Arrival Email and Cancelled Reservation & Cancelled Order.

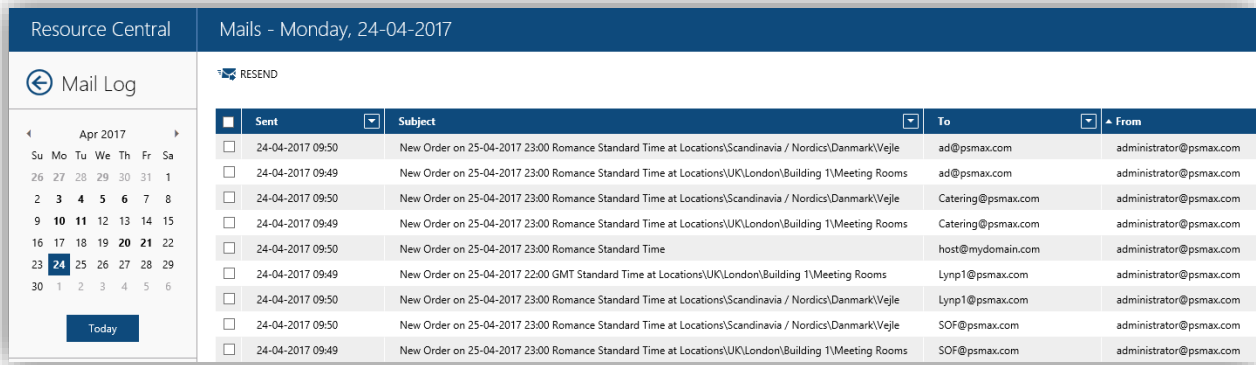

Figure 371. Mail Log

Toolbar button	Description
RESEND	Resends the selected mail(s)

SQL

This interface is provided for advanced level data management. Through this view, you can execute SQL statements directly on Database and view their result in form of a table.

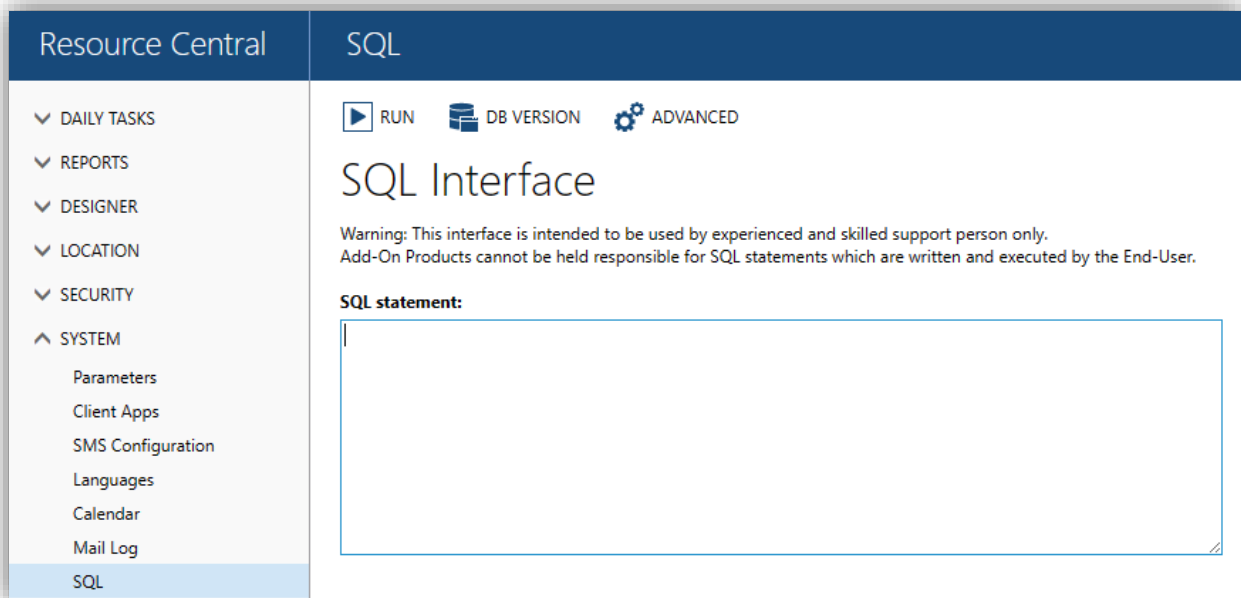

Figure 372. Database – SQL Design

If you click on the **[DB version]**, the database version in use will be displayed:

SQL statement:

```
SELECT
  IF(CHARINDEX('\', @@SERVERNAME) = 0, @@SERVERNAME, LEFT(@@SERVERNAME, CHARINDEX('\',
  @@SERVERNAME) - 1)) AS ServerName
  ,CASE WHEN @@servicename = 'MSSQLSERVER' THEN 'NULL' ELSE @@servicename END AS
  InstanceName
  ,DB_NAME() AS DataBaseName
  ,system_user as DataBaseUser
  ,(select value from DBVersion where property='applicationurl') AS 'RC URL'
  ,(select value from DBVersion where property='dbversion') AS 'RC DB Version'
  ,LEFT(@@VERSION, 55) AS SQLVersion
```

ServerName	InstanceNa...	DataBaseN...	DataBaseUser	RC URL	RC DB Versi...	SQLVersion	SQLBuild	Broker Status
RC1	NULL	RC	sa	https://rc1...	4.3.0006.0...	Microsoft ...	15.0.2000...	true

RC URL	Endpoint
ResourceServiceURL	https://rc1.add-on-company.com/ResourceCentralGateway/resource-api
ApplicationURL	https://rc1.add-on-company.com/ResourceCentral
ReservationServiceURL	https://rc1.add-on-company.com/ResourceCentralGateway/reservation-api
LocalReservationServiceURL	http://localhost/ResourceCentralGateway/reservation-api
NotificationServiceURL	https://rc1.add-on-company.com/ResourceCentralGateway/notification-api
VisitorServiceURL	https://rc1.add-on-company.com/ResourceCentralGateway/visitor-api

Figure 373. Show DB version

The following screen is the advanced mode of **SQL** which is accessed by clicking on **[Advance]** button. Through this interface you can download the result of **SQL** queries on your own machine. You can also execute the update query.

NOTE: It is strongly recommended that this interface must be used by experienced support personnel, who should be proficient in writing/using SQL statements and well aware of the Resource Central Database design. Incorrect use of this interface may halt the Resource Central System or may permanently destroy the data.

SQL

SQL Interface

Warning: This interface is intended to be used by experienced and skilled support person only.
Add-On Products cannot be held responsible for SQL statements which are written and executed by the End-User.

Download CSV file
 Download Text file
 Execute update query

SQL statement:

Figure 374. Advanced mode of SQL

Toolbar button	Description
RUN	Click this button to execute the query.
DB VERSION	Show Database version
ADVANCED	Advanced mode of SQL

Database Cleaner

This interface is provided for advanced level data management. Through this view, you can delete all the records of the reservations physically from the Database.

When you click the **Database Cleaner** node, the following screen will be displayed:

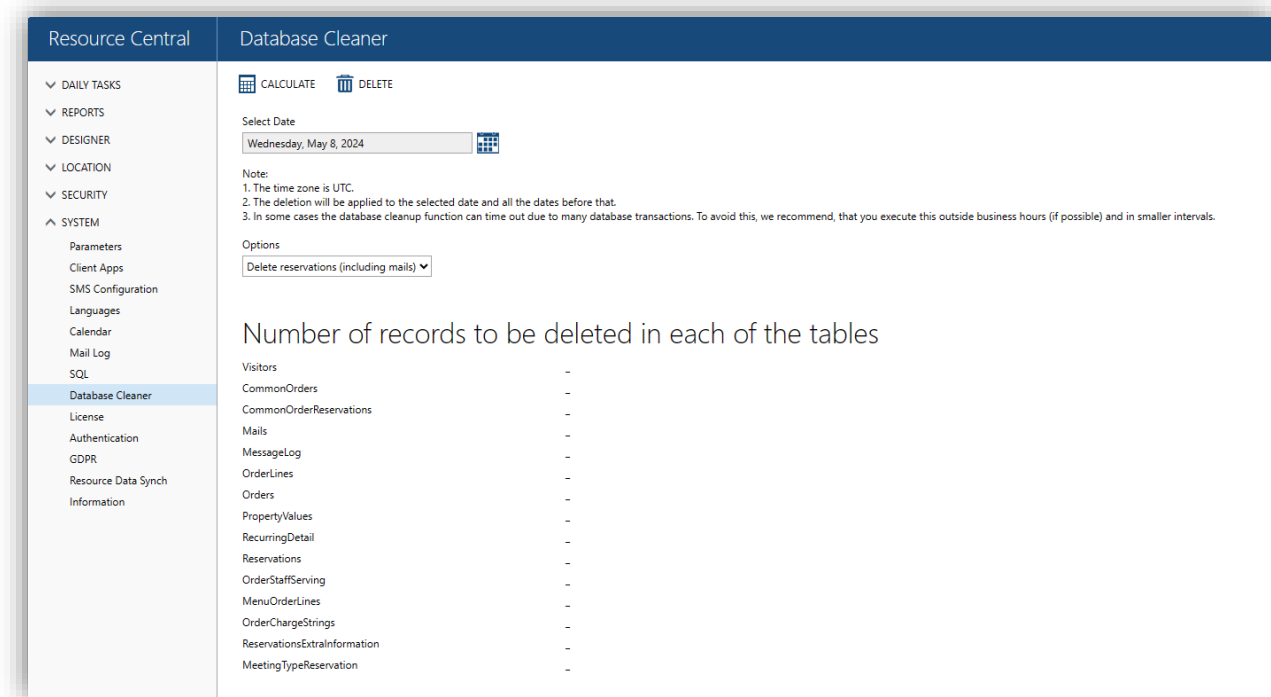

Figure 375. Database Cleaner

Toolbar button	Description
DELETE	Click Delete to physically delete the records from the database, as per the specified input
CALCULATE	Click this button to calculate number of records to be deleted

The working of this functionality is as follows:

- **Select Date:**
 - It is a calendar control with which you can select a date. The date could be any date in the past. You cannot select the current date or any date in the future, for which an error would be shown.
 - All reservations with the End Date being Equal to/Less than the selected date will be considered.
 - If a Recurring reservation has at least one instance with End date lying outside the selected date, the whole series of that Recurring reservation will be excluded from the input list, i.e., if the DB Cleaner is run, it will have no impact over the said Recurring Series.
- **Delete reservations (including mails):**



- If you select this option and run the DB Cleaner by clicking [**Delete**] from the toolbar, then all the Reservations including the Orders, Mails, Attendees, Extra Services Information etc. which are associated with the reservations will also be deleted physically from the system.
- Also, note that Visitors that have been associated with a reservation will not be deleted from the system. Instead, such visitors will be associated with the 'Host' user so that afterwards, you can associate those visitors with any other reservation from the **RC Admin → Daily Tasks → Visitors**.
- **Delete Mails only:**
 - If you select this option and run the DB Cleaner by clicking [**Delete**] from the toolbar, then all the Emails of those Reservations that satisfy the Calendar criteria will be deleted from the system.

If you select a date and then click [**Calculate**], the system will make a calculation of record number to be deleted:

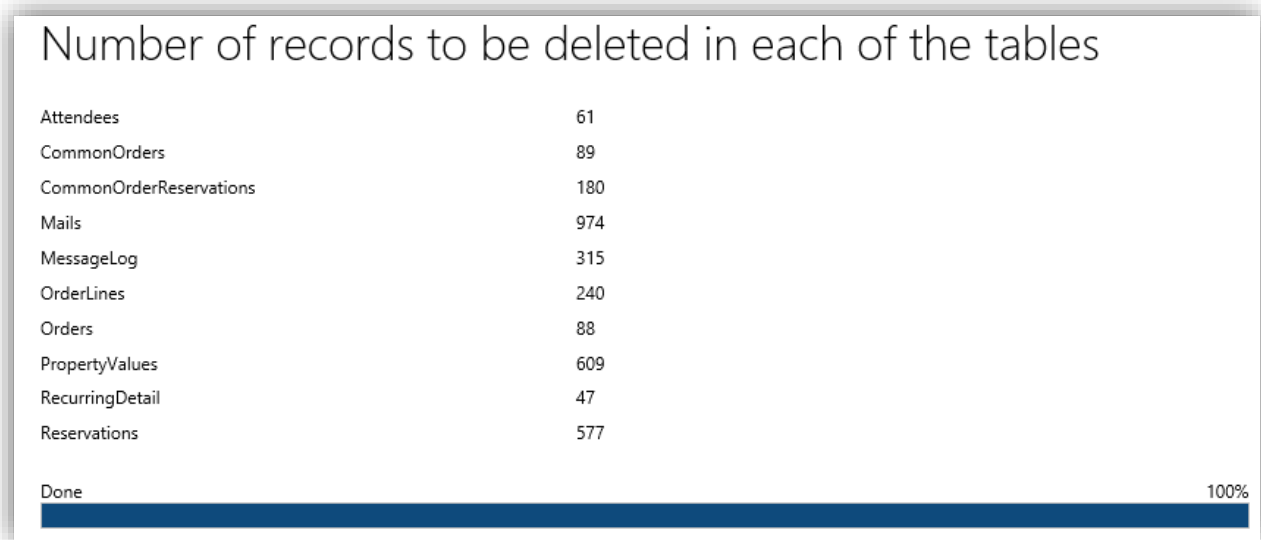

Figure 376. Calculation result

After selecting all of the inputs, and clicking [**Delete**] button at the toolbar, the records of all those reservations whose **Reservation End Time** is **Less than/Equal to** the selected date will be physically removed from the database of the application.

NOTE: Time Zone settings are applicable over this functionality. For further details of Time Zone impact, please refer to the **Chapter 5 → Time Zone Settings** in this document.

License

Add-On Products provides the license files to its clients, which must be uploaded into the system in order to use RC. The License screen is used for this purpose.

License information

On clicking the License link in left pane, details of the license being used for the application will be displayed on the right panel as shown in figure below:

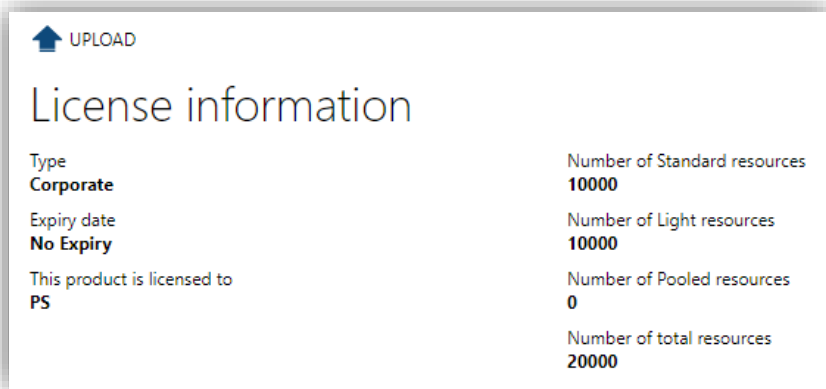

Figure 377. License Details

Field	Description
Type	Type of the license
Expiry date	Expiry date of the license
This product is licensed to	Name of the company
Number of Standard Resources	Maximum number of Standard resources allowed in the system
Number of Light Resources	Maximum number of Light resources allowed in the system (Light resources are those from which no emails are sent)
Number of Pooled Resources	Maximum number of Pooled resources allowed in the system. The usage of the Pooled resource Licenses is based on the sum of the capacity of all the resources created with license type Pooled Resource.
Total number of resources	Maximum number of resources, allowed to be created in system

License & Activation Key - Upload

User can upload the **XML** License file and the encrypted license key file through this interface. Both fields are mandatory.

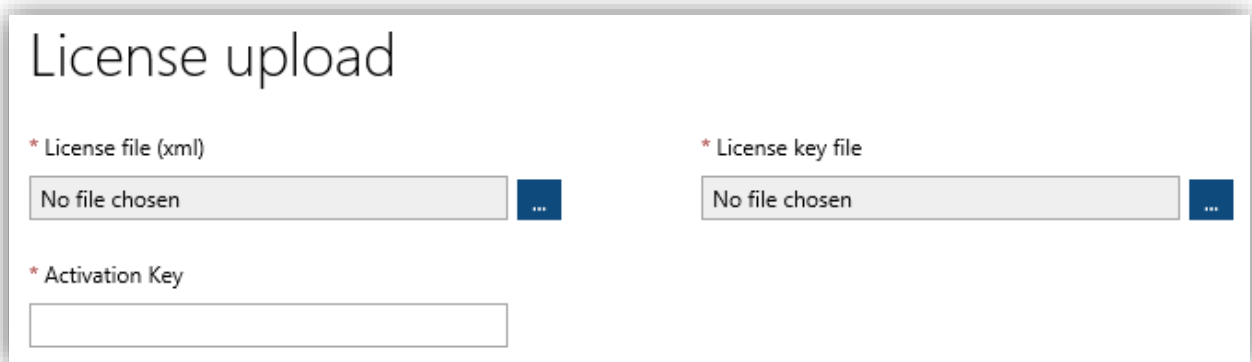

Figure 378. Upload License File

Field	Description
License file (xml)	Click the browse button and select the name and path of the License xml file which you have received
License key file	Click the browse button and select the name and path of the License key file which you have received
Activation Key	A 16-digit unique alpha-numeric Product Activation key which will be used to activate the RC Web application

Assumptions/Constraints regarding the License & Product Activation:

- If the user has neither provided the Product Activation, nor he has uploaded the new license file, then upon accessing **RC Manager → General → License** screen, a default label “**License/Activation key is invalid**” will be displayed, as shown below:

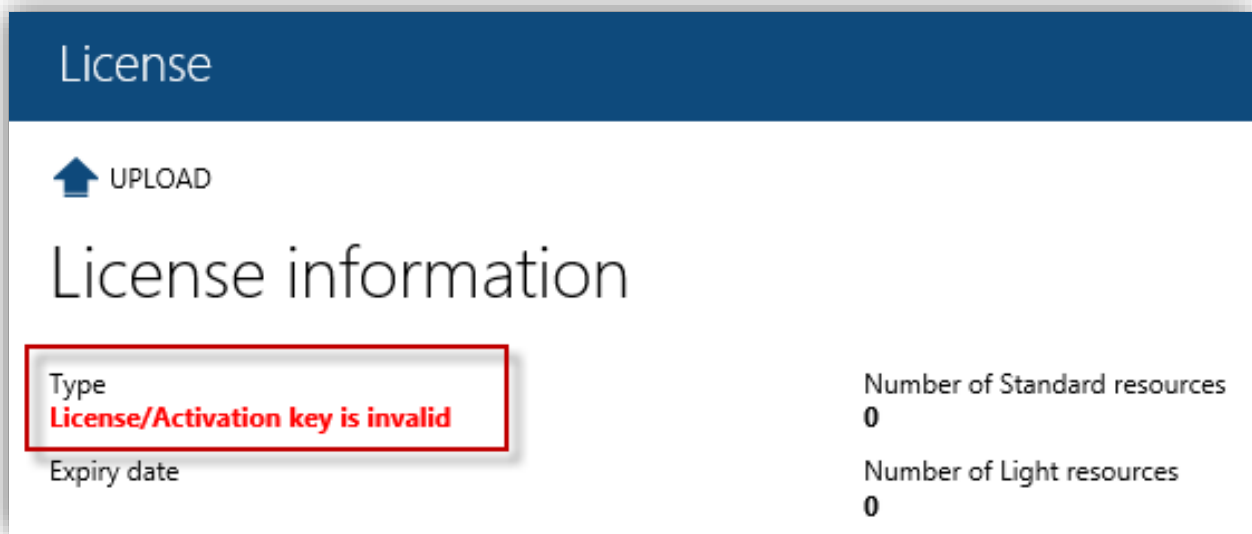

Figure 379. License

This same label will be displayed at the Login screen, all the emails & all the order forms in the RC system. Same is also true if the user has either uploaded only the correct activation or latest format license.

- If the user has uploaded both, correct license, and correct activation, then the actual license information will be displayed, and no warning label will be displayed.
- Please also note that the Product activation is not case-sensitive.

Authentication

External Authentication

This section allows you to make configuration for supporting login using a third-party authentication protocol.

The screenshot shows the 'Authentication' configuration page in the Resource Central Admin Interface. The left sidebar lists navigation categories: DAILY TASKS, REPORTS, DESIGNER, LOCATION, SECURITY, and SYSTEM. Under SYSTEM, options include Parameters, Manifest files, SMS Configuration, Languages, Calendar, Mail Log, SQL, Database Cleaner, License, Authentication (highlighted), GDPR, Resource Data Synch, and Information. The main content area is titled 'Authentication' and features a 'SAVE' button. Below it is the 'External Authentication' section with the following settings:

- Enable Configuration:** Yes No
- Remove form based login option:** Yes No
- Authenticated system areas:**
 - My Meetings Com Add-in
 - Resource Finder Com Add-In
 - Resource Finder & My Meetings Outlook Add-in
 - Kiosk
 - My Meeting stand-alone page
 - Specific users All authenticated users
 - Opening of links from Resource Central e-mails
 - Specific users All authenticated users
- * Authentication Protocol:** OAuth2 (selected in dropdown)
- OAuth2 Configuration:**
 - Azure OAuth2 OAuth2 with AD FS
 - * Reply URL:**
 - * Tenant (Tenant ID):**
 - * Client Id:**
 - * Client Secret:**
 - Auto-Login Networks:**

Figure 380. External Authentication

To start configuring, the 'Enable Configuration' option must be enabled. Then you can set up **Authenticated system areas** and **Authentication Protocol** to allow users login RC system using Microsoft accounts.

The **Authenticated system areas** selection includes:

- My Meetings Com Add-in
- Resource Finder Com Add-In
- Resource Finder & My Meetings Outlook Add-In
- Kiosk
- My Meeting stand-alone page

- Opening of links from Resource Central e-mails

When you make your selections, the selected areas will require users to login with their Microsoft accounts before using the services provided by those areas.

The authentication method is determined by the **Authentication Protocol** which requires you to select one protocol option. Note that the SAML2 option covers both Azure and ADFS.

Selecting a protocol will show its respective data fields that need to be configured. Depending on your selected protocol, please refer among the following articles for more details on how to configure and get authentication information:

- [OAuth2 in Azure](#)
- [OpenID Connect in Azure](#)
- [OAuth2 with AD FS](#)
- [OpenID Connect with AD FS](#)
- [SAML2 in Azure](#)
- [SAML2 with ADFS](#)

Optionally, you can fill in IP addresses or IP address ranges, each value in a line in the **Auto-Login Networks** field, e.g.:

Auto-Login Networks

153.177.122.10
192.168.1.1/24

When filled in, client machines with the filled-in IP address will be automatically logged in and use Single Sign-On function.

Apart from this, refer to [this article](#) to enable seamless SSO to work with RC Auto-Login Networks.

Person Authorization – Role Based Access Control

This option allows RC to manage Persons based on Azure’s Role Based Access Control (RBAC). The RBAC function is controlled by parameter **RC.Authentication.IsShowRBAC**. For more details about this parameter, please refer to **RC Parameter Guide**.

Person Authorization - RBAC

Enable Role Based Access Control (Azure)

Yes No

Number of days a RBAC Person can be inactive before the Person is deleted in Resource Central. (Blank value means that a user will be kept forever in RC)

When a Resource Central Role is mapped to an Azure app role, the Azure users signing into Resource Central with the Azure role in their AAD access token will be created as a Person in RC; thus, they gain access to specified sections in RC based on the role’s access control.

The benefit shortly stated is that the system administrators no longer need to manage each Person in Resource Central but can just add the users to the distribution list of the AAD role related to a specific role in Resource Central.

NOTE: Before enabling this feature, it is required to configure Azure app for this purpose beforehand. Refer to [RBAC Azure App Configuration Guide](#) for the instruction on how to perform this configuration.

For more details on the option and how configure it, refer to this [article](#).

Service Authentication

From RC 4.2 Hot Fix 8 onwards, you can configure an access code for Web API and Web Service to authenticate the communication between and with different Resource Central services.

To do so, go to **RC backend** → **SYSTEM** → **Authentication**, then go to 'Service Authentication' section:

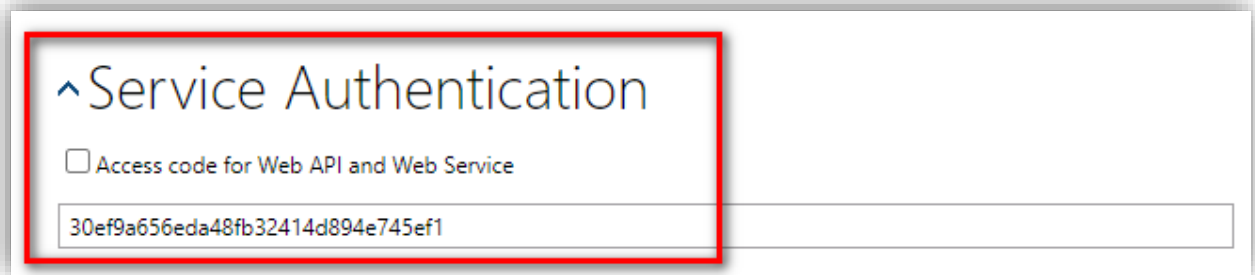

^ Service Authentication

Access code for Web API and Web Service

30ef9a656eda48fb32414d894e745ef1

Check on 'Access code for Web API and Web Service' option will generate a new code below.

NOTE:

- Authentication on Resource Finder Com Add-in combined with this Service Authentication requires a Com Add-in version of 4.1.X.
- If you uncheck 'Access code for Web API and Web Service' option, yet the code still exists, this function will actually be disabled.
- In order to generate new code, you need to delete the existing code. Then check on 'Access code for Web API and Web Service' option again.
- The access code can also be used to authenticate third party apps reading from ResourceInfo.asmx.

Resource Data Synch

NOTE: Availability of this feature depends on the parameter **RC.ResourceDataSynch.Enable**. For more details about this parameter, please refer to **RC Parameter Guide**.

This section allows you to establish which data fields from Exchange that can be synchronized to a resource.

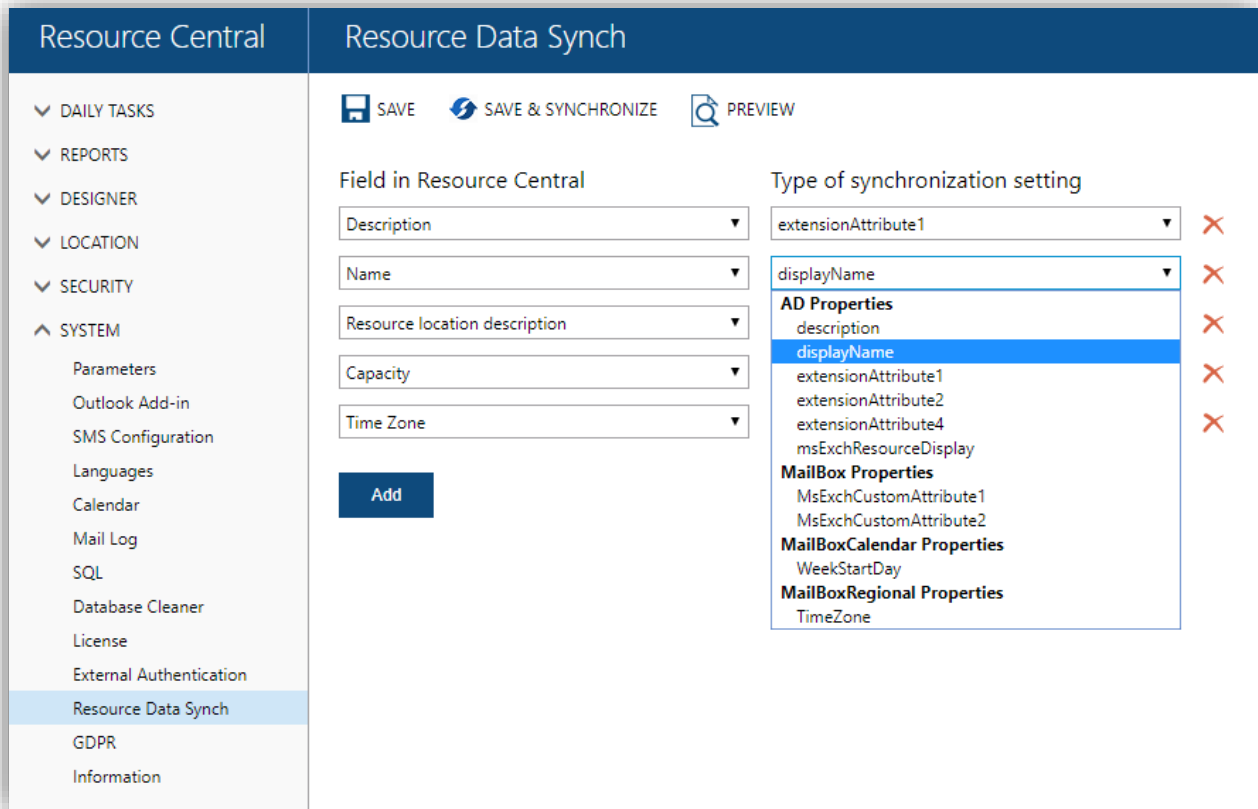

Figure 381. Resource Data Synch

You can select a field in Resource Central on the left, then on the right select the corresponding field in Exchange from which the data can be synchronized (Type of synchronization setting). Selections you make here are only possible if they are configured in RealTime Service. Please refer to the latest revision of **RealTime Service User Guide** for more details.

You can add more fields to set up a data synchronization between Exchange and Resource Central as you wish. Click **[Save]** or **[Save & Synchronize]** to finish.

Toolbar button	Description
SAVE	Save the configuration but does not initiate the synchronization process immediately. The synchronization process start time is controlled by the parameter RC.ResourceDataSynch.StartTime . For more details about this parameter, please refer to RC Parameter Guide .
SAVE & SYNCHRONIZE	Save the configuration and activates the synchronization process at once.
PREVIEW	See detailed description below

NOTE: Open Start/End time fields are only selectable if the Time Zone field is established. If you remove the Time Zone field, those 2 fields will be accordingly removed.

Clicking **[Preview]** on the toolbar opens a panel in which you can search for the resource that you want to preview. This allows you to see how the mapping will look on the resources when the new configuration is saved and synchronized. This can be an advantage before an initial synchronization, where you can validate the quality of your organization’s Exchange data values to avoid wrong updates into Resource Central.

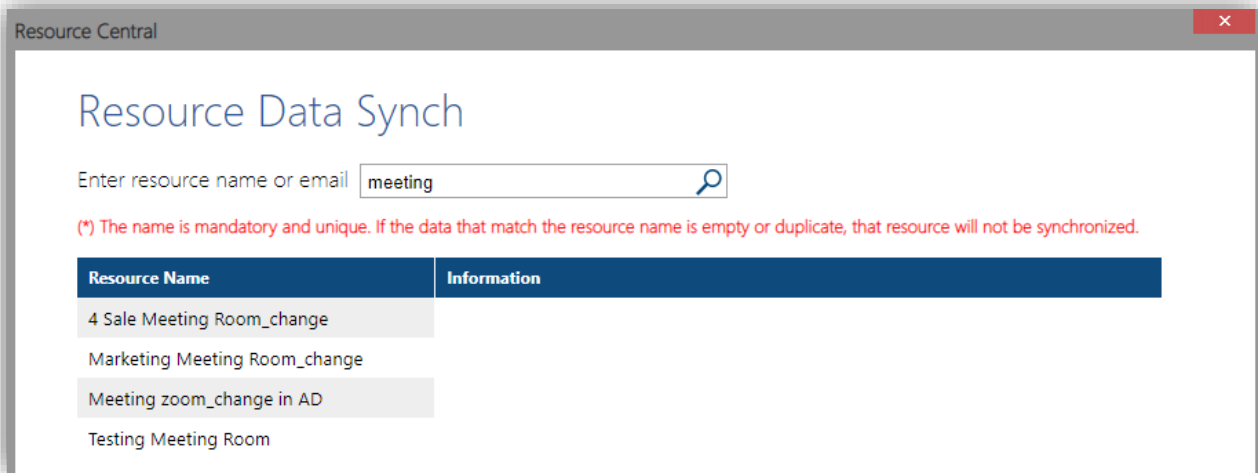

Figure 382. Preview a resource

Type the keyword into the text box and click the magnifier icon, a list of resources that matches your keyword is displayed. Click on a resource, its information and mapped fields are shown on the right side of the panel:

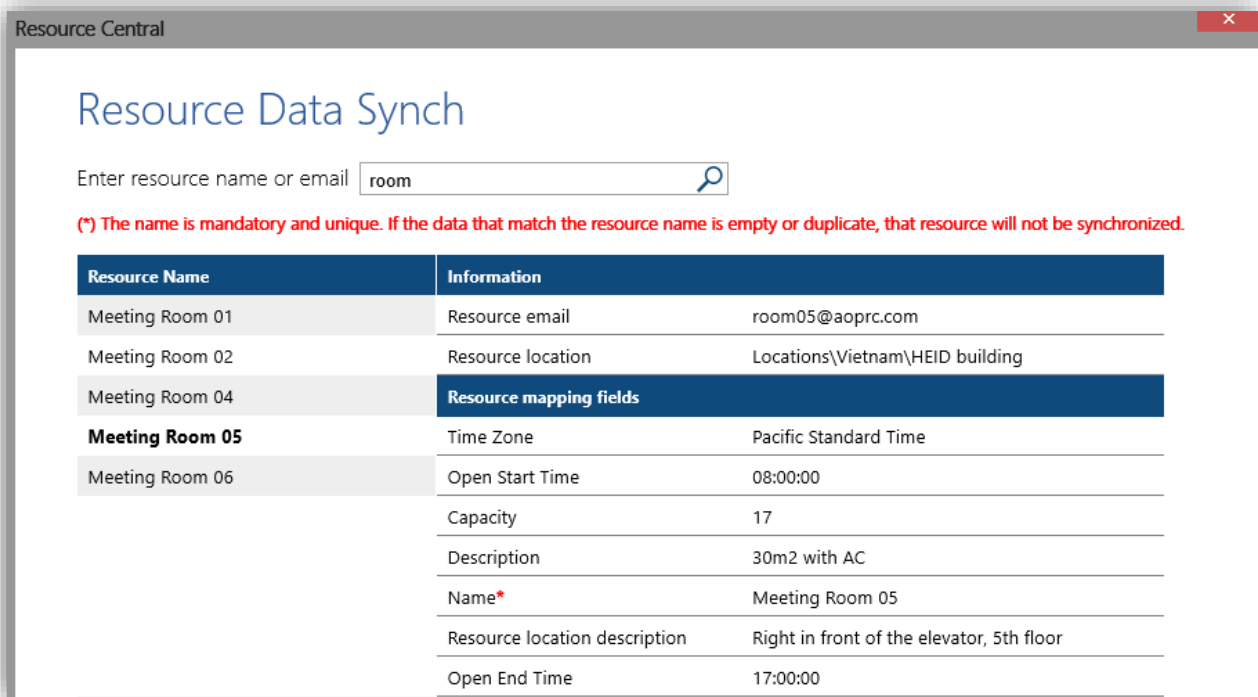

Figure 383. Resource’s mapped fields

If you click **[Export all resources]**, this information of all resources in the system will be exported to an Excel file, where you can easily preview the mapping for all resources. A benefit for a validation and consistency checking at initial synchronization of a lot of resources and Exchange date values.

NOTE: The preview function gives an initial overview of the configured mapping between Resource Central, Exchange and Active Directory before the first synchronization of the resource data. The preview function can give a quick overview of missing resource data in Exchange and Active Directory.

The preview will not reflect live updates from either of the two environments. Therefore, the preview is not intended as an audit tool for the data properties on each resource from Exchange and Active Directory. Updates of data properties can be seen directly in Resource Central after the scheduled synchronization has run.

GDPR

In this section, you can handle the personal General Data Protection Regulation (GDPR) data. You can make use of this function when you want to view, filter, and anonymize selected data.

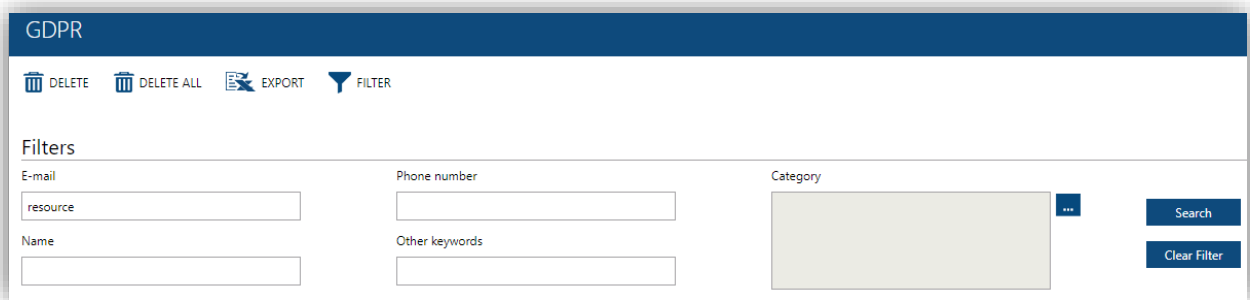

Figure 384. GDPR

Toolbar Buttons	Description
DELETE	Delete selected data
DELETE ALL	Delete all records
EXPORT	Export data in the result to Excel
FILTER	Set up filter for searching

Input keyword to relevant fields and click [**Search**] or press [**Enter**], the full-text search will be implemented and the result will be displayed underneath.

NOTE:

- Apart from **E-mail**, **Phone number** and **Name**, you can input any other information (address, passport ID, etc.) into **Other keywords** field to search. The purpose of input distribution is to direct the search and display the result (i.e. if you cannot search for the information you need with a certain keyword in the 3 specific fields, you can try inputting that keyword into **Other keywords** field).
- Filter condition should contain words or phrases.
- Avoid using only numbers on filter if possible.
- If filter condition must be number, try to input as many numbers as possible.

The result is displayed in 3 tabs: **Reservation**, **Visitor** and **Miscellaneous**. Look for the data you need in the relevant tab.

In case the feature Visitor cleanup is enabled (refer to [Other Visitor settings](#)), the GDPR filter will only show visitor data that is within specified period by the parameter **Visitor.InfoRetention.Days**.

Visitor data that is older than the specified period will be deleted, thus, it will not appear on GDPR page.



Information

This section provides you with all information related to the system and application.

Resource Central version	Installation date
4.3.0007.0002	2024/03/05
RealTime Service	OS version
6.6.34.12	Microsoft Windows NT 10.0.14393.0
SQL version	Exchange version
Microsoft SQL Server 2019 (RTM) - 15.0.2000.5 (X64)	Exchange2013

Figure 385. Platform information

CHAPTER 5.

Time Zone Settings

Resource Central provides you with a facility to adjust the timings according to your locations. For this reason, **Time Zone Settings** have been made available in the system through which you can configure the application according to your local time zone.

Application Time Settings

As a first step, you would have to specify the Time Zone for the Application. It can be configured when you access the Initial Setup Screen for the first time. It can also be configured later from **RC Manager → General → Parameters → Basic Parameters**.

'Use Default Time Zone' parameter is used by Resource Central application to configure Time Zone settings.

- If the parameter has 'Yes' value, the selected **Time Zone** value in basic parameters will be applicable in entire Resource Central application.
- If the parameter has 'No' value, the selected **Time Zone** value in basic parameters will only be used when the Resource or Person has no **Time Zone** value.

Setting up Time Zone from Basic Parameters

Application time zone can be setup from **Basic parameters** section in Resource Central Manager, as shown below:

The screenshot shows the 'Basic Parameters Details' configuration screen. The 'Time Zone' dropdown menu is highlighted with a red box and shows '(UTC+01:00) Brussels, Copenhagen, Madrid' selected. Other fields include 'RTS Service Endpoint', 'System Email', 'Main Logo', 'Time Slot', 'Date Format', and 'Date Separator'.

Figure 386. Basic Parameters Screen

When you click upon the arrow button beside the **Time Zone** Field, the following window will appear, containing the list of all the available Time Zones as shown below:

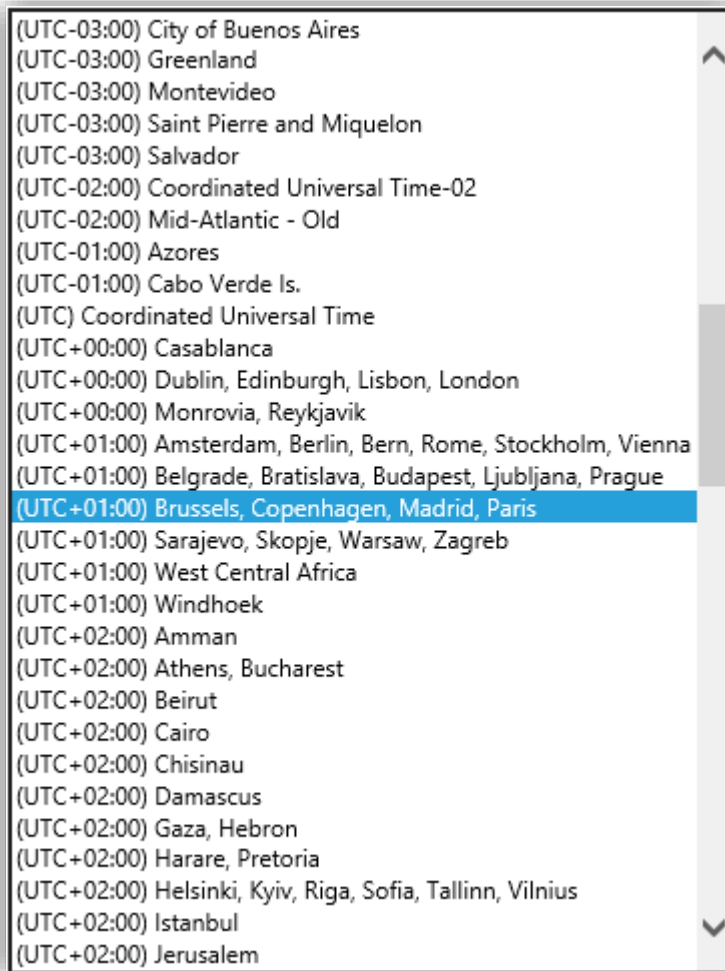

Figure 387. List of Available Time Zones

Default Time Zone value Impact

The relation and the impact of the 'Use Default Time Zone' parameter value can be understood by the following matrix:

Use Default Time Zone Parameter	'No' value	'Yes' value
Resource Central Admin	Resource Time Zone & Person/User Time Zone is applicable (if specified)	Value of Basic Parameter 'Time Zone' is applicable (Resource & User Time Zone values will be ignored)
Resource Central Manager	'system' user Time Zone is applicable (if specified)	Value of Basic Parameter 'Time Zone' is applicable (user 'system' Time Zone value will be ignored)
ResourceFinder	Client's Local Machine's Time Zone is applicable	Value of Basic Parameter 'Time Zone' is applicable (Client's Local Machine's Time Zone value will be ignored)
My Meetings	Client's Local Machine's Time Zone is applicable	Value of Basic Parameter 'Time Zone' is applicable (Client's Local Machine's Time Zone value will be ignored)



Time Zone Settings in ResourceFinder

Resource Central allows you to customize the Time Zone settings of **ResourceFinder** application which is integrated into the MS Outlook.

- If the '**Use Default Time Zone**' parameter has **No** value, ResourceFinder window will show resource booking status according to the machine time zone settings as configured on the client machine.
- If the '**Use Default Time Zone**' parameter has **Yes** value, all resource bookings and status in ResourceFinder window will be shown according to the **Time Zone** value selected in **Basic Parameters** section.

Daylight Savings Time

If the Client local machine is running in Standard Time Zone in which the Day Light Savings is **enabled**, ResourceFinder Outlook view will display the bookings status according to the Day Light Saving Settings.

Time Zone Settings in My Meetings

Resource Central allows you to customize the Time Zone settings of **My Meetings** interface which is integrated into MS Outlook.

- If the basic parameter '**Use Default Time Zone = No**', My Meetings window will be updated according to the machine time zone settings as configured on the client machine. That is, the Calendar control & corresponding reservation date/time at the summary screen would be displayed according to the machine time zone value. When the user clicks to see details of the reservation, it may be possible that the date/time being displayed on the Order Form is different from the time displayed at the summary screen. This can only be possible if the specified resource time zone is different from that of the machine time zone.
- If the basic parameter '**Use Default Time Zone = Yes**', My Meetings window will be updated according to the value of the basic parameter **Time Zone**. That is, the Calendar control, corresponding reservation date/time at the summary screen and the date/time displayed at the Order Form in the details of a reservation will always be displayed according to the value of the basic parameter **Time Zone**, thus ignoring the Machine and Resource Time Zone values.

Time Zone in Web Access of My Meetings

Resource Central allowed web access of **My Meetings** interface. My Meetings interface can be accessed by typing the following URL in the browser:

[http\(s\)://<ServerName>/<VirtualDirectoryName>/MA/Frontcontroller.aspx?user=<OrganizerEmail>](http(s)://<ServerName>/<VirtualDirectoryName>/MA/Frontcontroller.aspx?user=<OrganizerEmail>)

- If the '**Use Default Time Zone = No**' and a user log in the Web Access of My Meetings, the Date/Time across the Web Access of My Meetings is displayed according to the logged in user's time zone. Calendar date, start and end time values will be shown according to the logged in user's time zone settings. However, Reservation time (start & end time) and Serving time values shown in order form will be shown according to the Resource Time.
- If the Time Zone of the logged in user is not specified, then the value of Basic parameter **Time Zone** will be used for this purpose.
- If the '**Use Default Time Zone = Yes**', and a user logs in the Web Access of My Meetings, all time values in My Meetings page will be shown according to the **Time Zone** value selected in **Basic Parameters** section.

Daylight Savings Time

If the Client's local machine is running in such a Time Zone in which the Day Light Savings is **enabled**, My Meetings Outlook access will display the Time values according to the Day Light Saving Settings.

Time Zone Settings in Resource Central Admin Interface

The Time zone settings are applicable in the Resource Central Admin site. The Date/Time being displayed across the Resource Central Admin Interface will be based on the **Time Zone** value selected in **Basic Parameters** section.

However, in addition to the Time Zone, you can customize the Date/Time being displayed by specifying individual time zones of Resources & Users.

Resource Time Zone

Resource Central allows you to customize the Date/Time at Resource Level. You can specify the Time Zone for a particular resource. Navigate to **Resource Central Admin → Designer → Resources**. Click to see the details of a resource and specify a Time Zone from the lookup button beside the Time Zone field.

* Light Resource
 Yes No

* Group Name
 Large Room

* Location
 Locations

Time Zone
 (UTC+01:00) Brussels, Copenhagen, Madrid, ...

Category5

Image

Sign Name

* Send Email
 Yes No

ResourceFinder Properties

Figure 388. Resource Central Admin Interface → Designer: Resource Details

Here you can **assign** a time zone to a resource by selecting from the list of Available Time Zones. When the selected Time Zone is saved, the Date/Time Information will be displayed according to the Resource Time Zone in the Order Form and respective emails.

You can also **clear** an already assigned Time Zone by selecting the **Blank** Time Zone from the list.

(UTC-12:00) International Date Line West
 (UTC-11:00) Coordinated Universal Time-11
 (UTC-10:00) Hawaii
 (UTC-09:00) Alaska
 (UTC-08:00) Baja California
 (UTC-08:00) Pacific Time (US & Canada)
 (UTC-07:00) Arizona
 (UTC-07:00) Chihuahua, La Paz, Mazatlan
 (UTC-07:00) Mountain Time (US & Canada)
 (UTC-06:00) Central America
 (UTC-06:00) Central Time (US & Canada)
 (UTC-06:00) Guadalajara, Mexico City, Monterrey
 (UTC-06:00) Saskatchewan
 (UTC-05:00) Bogota, Lima, Quito, Rio Branco

If the Time Zone of the Resource is not specified, the Date/Time in Order Form and emails will be displayed based on the **Time Zone** value selected in **Basic Parameters** section (These cases are applicable only when the Basic Parameter '**Use Default Time Zone = No**')

If '**Use Default Time Zone = Yes**', then all the information across the Resource Central Admin Interface will be displayed based on the **Time Zone** value selected in **Basic Parameters** section.

Person/User Time Zone

Resource Central allows you to customize the Date/Time at User Level. You can specify the Time Zone for a particular user. Navigate to **Resource Central Admin → Security → Persons**. Click to see details of a person and specify a Time Zone from the lookup button beside the Time Zone field.

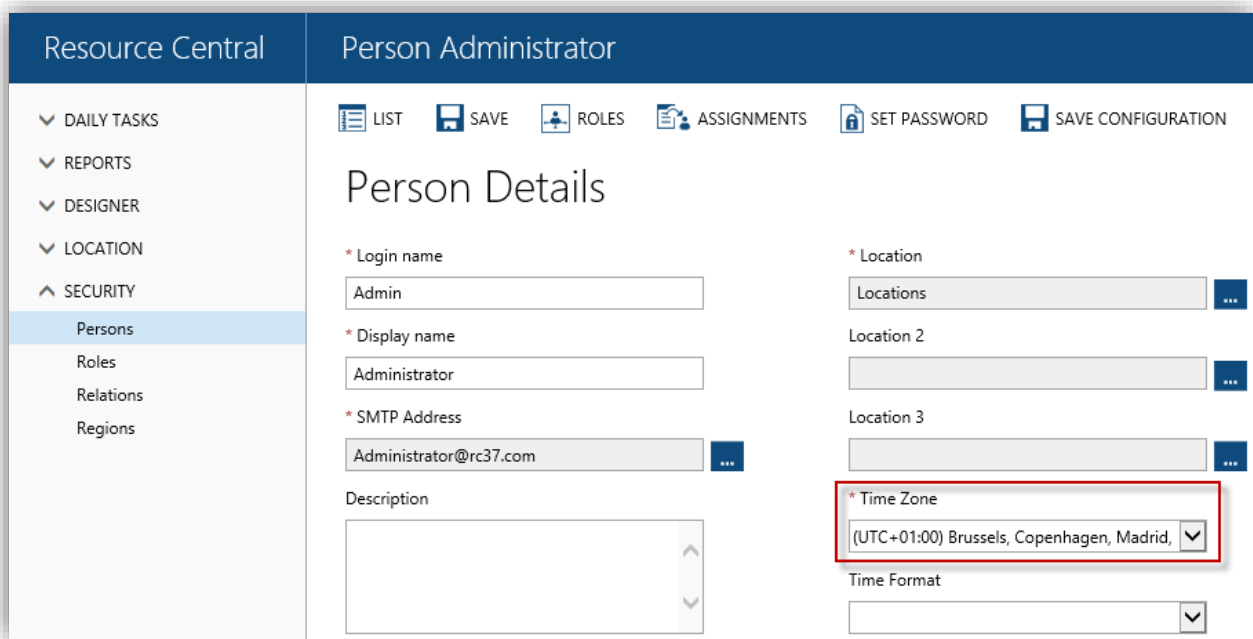

Figure 389. Resource Central Admin → Security: Person Details

Here you can **assign** a Time zone to a person by selecting from the list of Available Time Zones. When the selected Time Zone is saved, the Date/Time Information will be displayed according to the Person/User Time Zone value in the respective areas of the Order Flow.

You can also **clear** an already assigned Time Zone by selecting the **Blank** Time Zone from the list. Remember, if the Time Zone of the Person/User is not specified, the Date/Time will be displayed according to the **Time Zone** value selected in **Basic Parameters** section. (This is applicable only if the Basic Parameter '**Use Default Time Zone = No**').

If '**Use Default Time Zone = Yes**', then all the information across the Resource Central Admin Interface will be displayed according to the **Time Zone** value selected in **Basic Parameters** section and the values of Person/User Time Zone will be **ignored**.

Daylight Savings Time

If you have assigned such a Time Zone to the Resource or User in which the Day Light Savings is **enabled**, the system will convert the Date/Time according to the Day Light Saving Settings.

Time Zone Settings in Order Flow

Time Zone values are also reflected across the Order flow. The nature of the impact and the areas of impact are discussed below in detail.

Order Form for Meeting Organizer

- If 'Use Default Time Zone = No' and the meeting organizer opens the order form reservation email. The reservation time and the serving times at the order form will be displayed according to the specified **Resource Time Zone** settings.
- If Resource Time Zone settings have not been specified, then the reservation time and serving times over the order form will be displayed according to the value of 'Time Zone' given in basic parameter, as shown below:

Location: Locations\Europe\Germany

Subject: Project Meeting

From: 30-09-2016 02:30 PM (Friday)

To: 30-09-2016 03:00 PM (Friday)

Capacity: 10

STANDARD MEETING ROOM 217

STANDARD MEETING ROOM 217 order

If you require extra services for your resource booking, please enter the number of deliveries, and fill out this form.

Number of deliveries: 1 Delivery

1st service: 2:00 PM [9:00 AM] Delivery time at resource's local time

Serving 1

Name	Price
------	-------

Figure 390. Order Form for Meeting Organizer

- If 'Use Default Time Zone = Yes' and now the meeting organizer navigates to the order form to place the order. The reservation time and the serving times at the order form would be displayed according to the value of basic parameter 'Time Zone' value and the Resource Time Zone Settings will be ignored.

Order Form for Service Provider/Role

- If Person/User Time Zone settings have not been specified, then serving time in the order form of Service Provider will be displayed according to the value of 'Time Zone' given in basic parameter, as shown below:

Resource Central

Reply

You can only edit the parts of the order that you are responsible for. A new order confirmation will be sent to the organizer and the other people to which the change(s) applies.

^ Detailed information about your booking

^ Order details

Serving 1 at 11:30 AM

Name	Qty	Consumed Qty
Coffee	3	
Tea	1	

Add

Figure 391. Order Form for Service Provider/Role

- If 'Use Default Time Zone = No' and the Service Provider opens the order form by the link provided in the email sent to him/her. The serving times at the responsible role's order form will be displayed according to the specified **Person/User Time Zone** settings.

- If **'Use Default Time Zone = Yes'** and Service Provider opens the order form by the link provided in the email sent to him/her. The serving times at the responsible role's order form will be displayed according to the value of **'Time Zone'** given in basic parameter and the Person/User Time Zone Settings will be ignored.

Reservation Emails

- If **'Use Default Time Zone = No'** and a New Reservation is placed, an email is sent to the meeting organizer. The **Resource Time Zone Settings** will be displayed in the email **Subject**.
- If Resource Time Zone settings have not been specified, then the time in the subject of email will be displayed according to the value of **'Time Zone'** given in basic parameter, as shown in figure below:

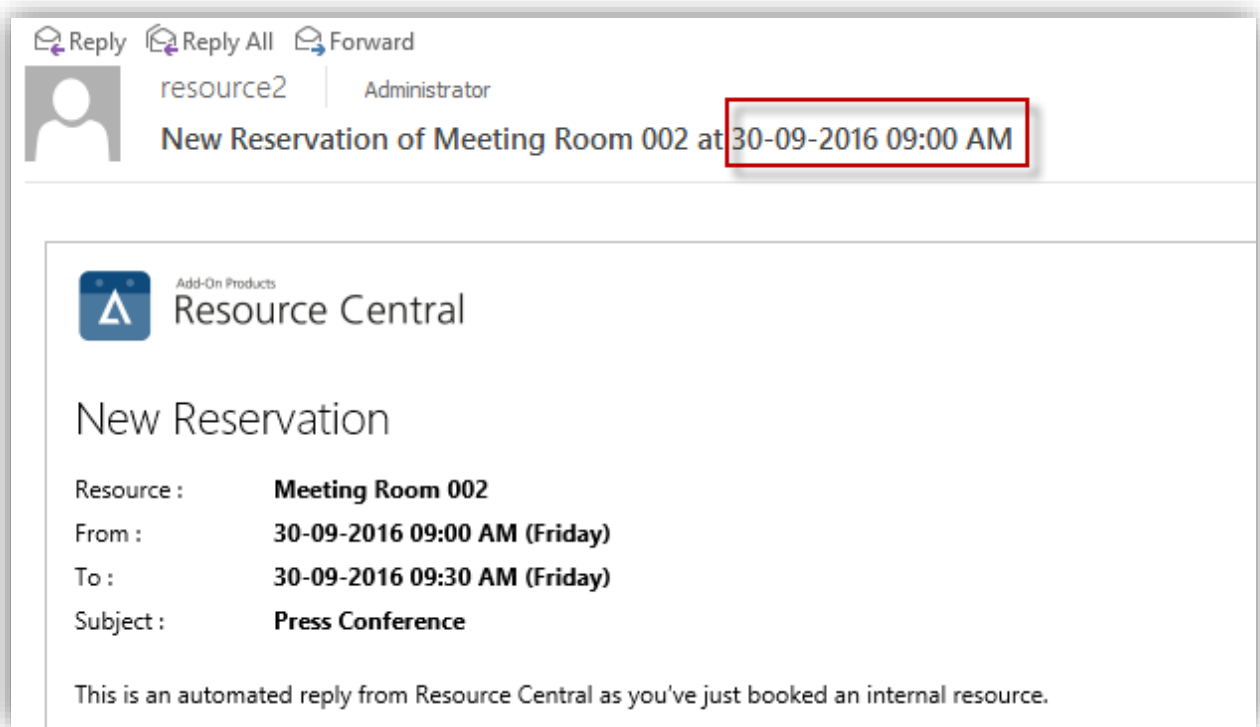

Figure 392. New Reservation Email with Time Zone values

- If the **'Use Default Time Zone = Yes'** and a New Reservation is placed, an email is sent to the meeting organizer. The value of basic parameter **'Time Zone'** will be displayed in **Subject** of New Reservation Email and Resource Time Zone settings will be ignored.

Time zone values are shown in subject of the following emails:

- New Reservation
- Changed Reservation
- Cancelled Reservation
- New Order
- Changed Order

Order Emails sent to Meeting Organizer

- If 'Use Default Time Zone = No', **Subject** of all the emails sent to the meeting organizer will show the **Time Zone** value given in **Resource Details**.
- If Resource Time Zone settings have not been specified, then the time in subject of all the emails sent to the meeting organizer will be displayed according to the value of '**Time Zone**' given in basic parameter, as shown below:

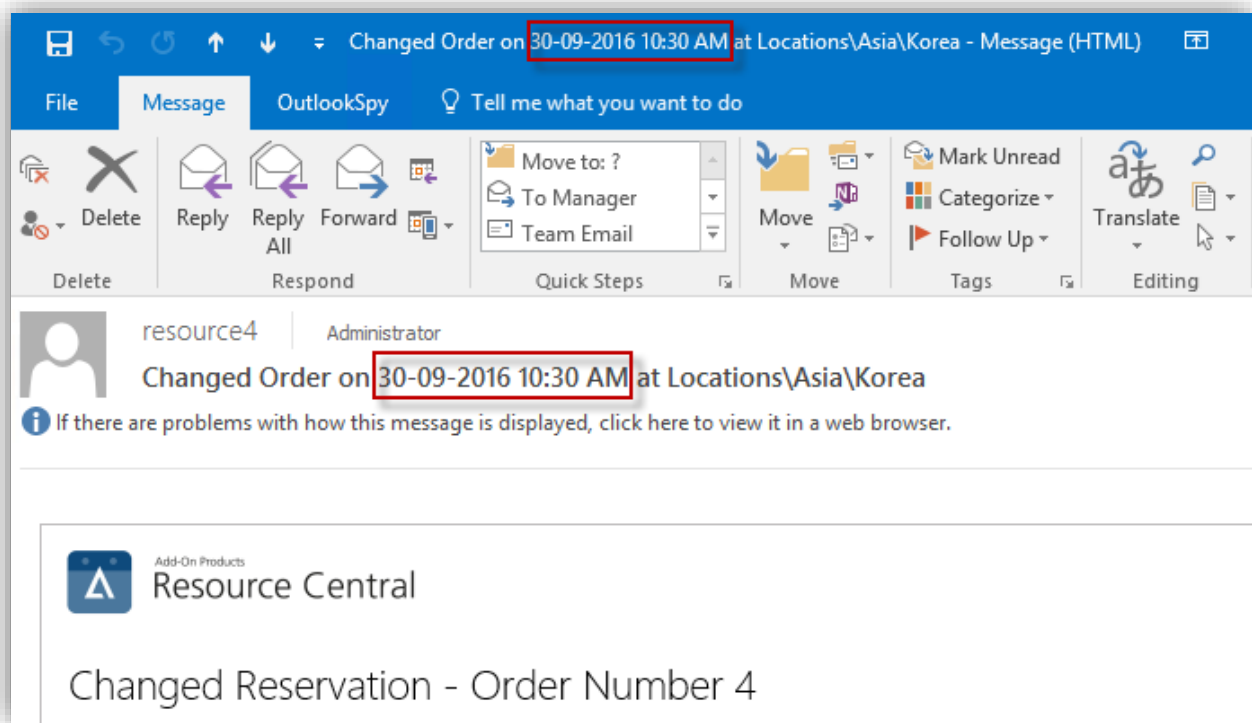

Figure 393. Changed Order Email to Meeting Organizer with Time Zone values

- If the 'Use Default Time Zone = Yes' then the time being displayed in **Subject** of all the emails sent to the meeting organizer will show the times according to the value given in 'Time Zone' field in basic parameter. Resource Time Zone settings in this case will be ignored, as shown below:

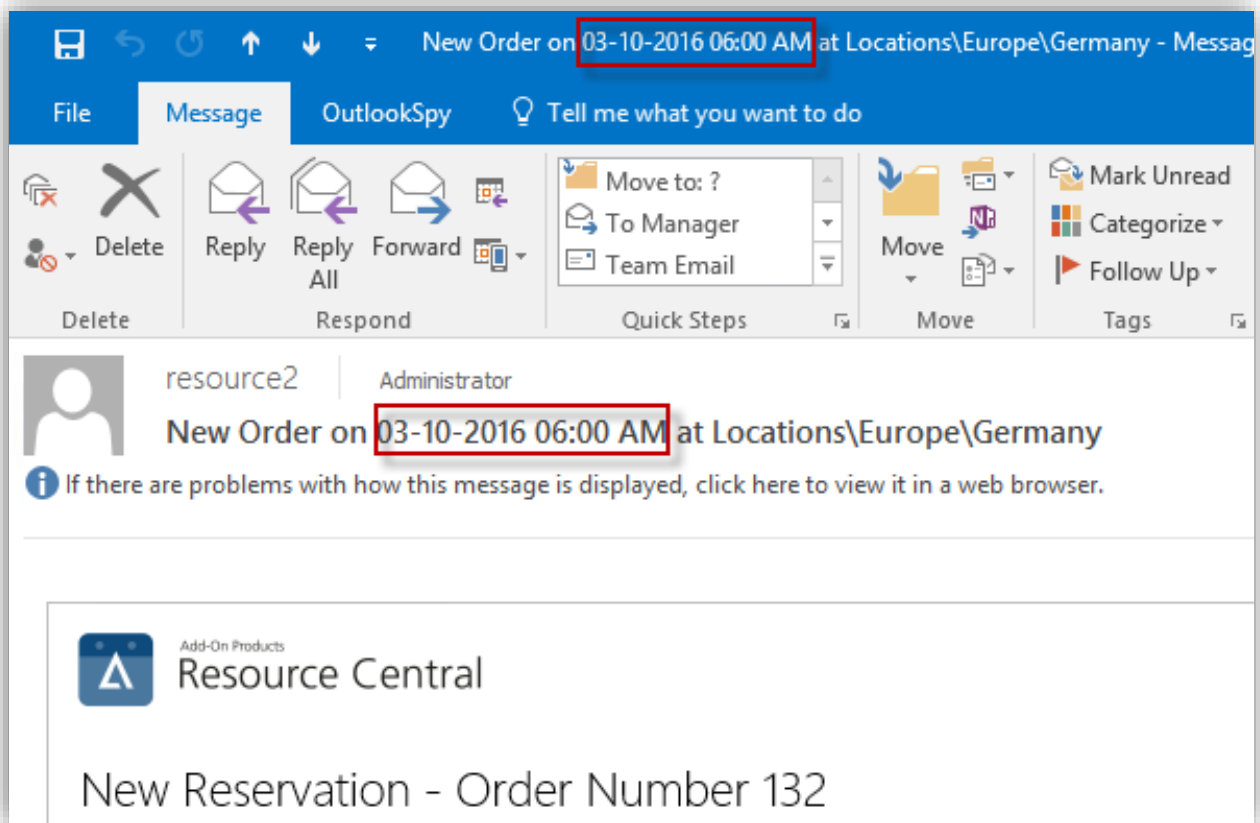

Figure 394. New Order Email to Meeting Organizer with converted Time Zone values

Order Emails sent to Service Provider/Role

- If 'Use Default Time Zone = No' then the time value shown in **Subject** of all the emails sent to the Service Provider will show the **Person/User Time Zone Settings**.
- If Person/User Time Zone settings have not been specified, then the time value shown in subject of all the emails sent to the Service Provider will be displayed according to the value of 'Time Zone' field in **basic parameters**, as shown below:

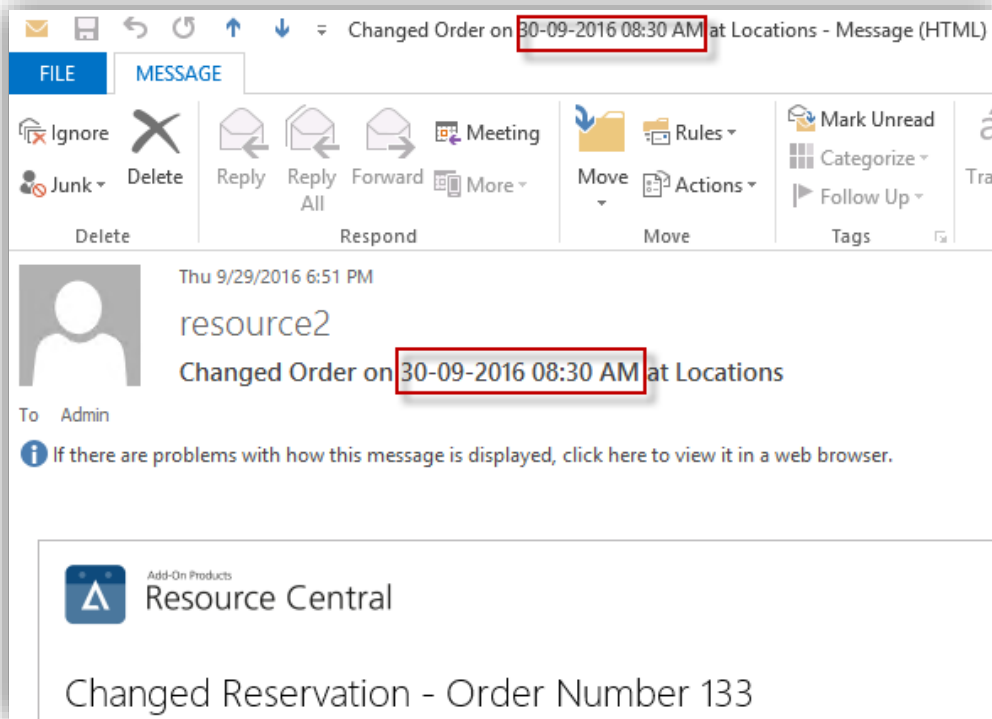

Figure 395. Changed Order Email to Responsible Role with Time Zone values

- If the 'Use Default Time Zone = Yes' then the time shown in **Subject** of all the emails sent to the Service Provider will show the times according to the value of 'Time Zone' in basic parameter. Person/User Time Zone settings in this case will be ignored, as shown below:

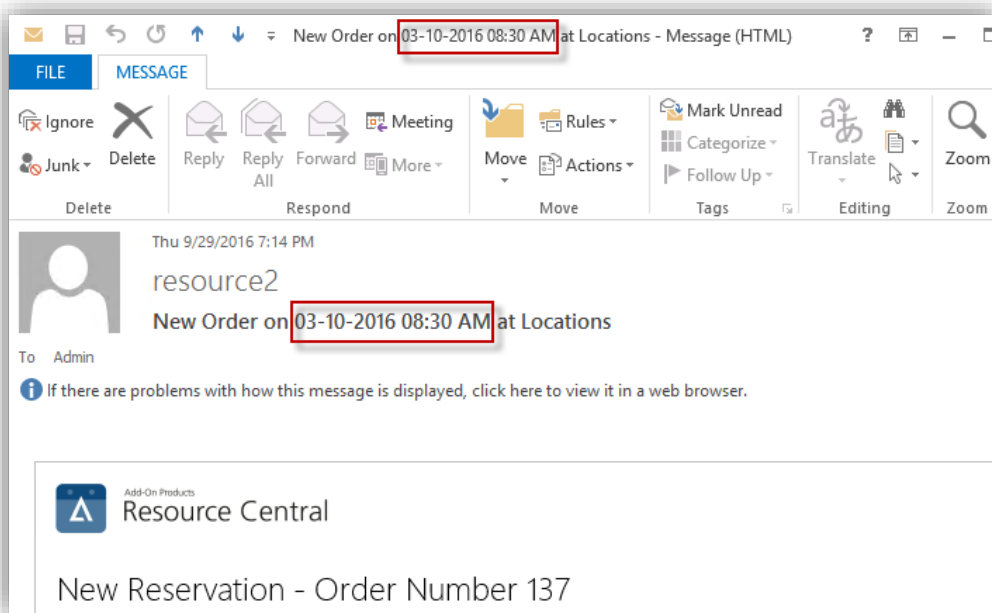

Figure 396. New Order Email to Responsible Role with converted Time Zone values

Time Zone Settings in Resource Central Manager Interface

Resource Central allows you to customize the Date/Time at User Level on the Resource Central Manager site also. You can specify the Time Zone for the user 'system'. Navigate to **Resource Central Manager → General → Credentials**. Specify a Time Zone from the lookup button beside the 'Select Time Zone' field and then click [Save] to save the changes.

The screenshot shows the 'Credentials' page in the Resource Central Manager interface. The page title is 'Credentials' and the main heading is 'Credential Details'. There is a 'SAVE' button in the top left. The 'Username' field is filled with 'System'. The 'Select the Time Zone' dropdown menu is highlighted with a red box and shows '(UTC-06:00) Central Time (US & Canada)'. Other fields include 'Old password', 'New password', 'Confirm new Password', 'Date Format', 'Time Format', and 'Date Separator'.

Figure 397. Resource Central Manager - Credentials

Here you can **assign** a Time zone to the user 'system' by selecting from the list of Available Time Zones. When the selected Time Zone is saved, the Date/Time Information will be displayed according to the Time Zone value across the entire Resource Central Manager interface.

You can also **clear** an already assigned Time Zone by selecting the **Blank** Time Zone from the list. Remember, if the Time Zone of the user 'system' is not specified, the Date/Time across the Resource Central Manager interface will be displayed according to the **Time Zone** value selected in **Basic Parameters** section.

Daylight Savings Time

- If 'Use Default Time Zone = No' and you have assigned a Time Zone to the user 'system' in which the Day Light Savings is **enabled**, the system will convert the Date/Time according to the Day Light Saving Settings across the Resource Central Manager interface.
- If 'Use Default Time Zone = Yes', then all the information across the Resource Central Manager Interface will be displayed according to the **Time Zone** value selected in **Basic Parameters** section.

CHAPTER 6.

Digital Signage Integration

Digital Signage Export is a Windows Service, which facilitates the integration of Resource Central with external systems. This service extracts the data of future reservations from RC database and saves it in form of an XML file as configured by the organizer and uploads it to an FTP Server.

In order to enable the Resource Central application to coordinate with the Digital Signage Export, the following parameters should be created in the RC application. These parameters will be created at **RC Manager → General → Parameters** section.

Parameters	Descriptions
DigitalSignExportCustomerID	Its value is used as customer ID in the fetched records in the output XML. Its value is also used as target XML File Name.
DigitalSignExportEventDescription	You will have to create a property with the same name as given in this parameter's value. This property would be associated with the resource in order to populate it in the Event Name field in output XML file.
DigitalSignExportCompanyName	You will have to create a property with the same name as given in this parameter's value. This property would be associated with the resource in order to populate it in the Company Name field in output XML file.
DigitalSignExportGroupEvent	You will have to create a property with the same name as given in this parameter's value. This property would be associated with the resource in order to populate it in the Groupevent field in output XML file.
DigitalSignExportUseMeetingDoorSign	You will have to create a property with the same name as given in this parameter's value. This property would be associated with the resource as a checkbox, with the value 'YES'. If the organizer checks this property while placing an order against a reservation, that reservation would be included in output XML file.
DigitalSignExportUseSubject	This parameter controls if reservation subject is automatically copied into the field 'Eventname' in the Digital Signage XML file exported from Resource Central and into 'Event' field in a signage's details. If value of this parameter is '1', Resource Central will automatically copy reservation subject to the field 'Eventname' in the XML file and into 'Event' field of a signage's details. If this parameter is not created or created with any value other than '1', the reservation subject is not copied to the XML file or 'Event' field of a signage's details.

NOTE:
The Properties can be defined at **Resource Central Admin → Designer → Properties**

For a reservation to be listed in the XML, following conditions should be met:

- The reservation should be a future reservation. That is, its meeting time should not have passed.
- The order status of this reservation should be New or Changed.
- The checkbox of the USE_MEETING_DOOR_SIGN property should be checked.

Other details regarding this Digital Signage Export configuration utility could be found in the Resource Central Installation Guide.doc



The output XML would look like this:

```
<?xml version="1.0" encoding="iso-8859-1" ?>
- <Events>
- <Event>
  <CustomerID>customer</CustomerID>
- <Eventname>
  <![CDATA[ event 2to 5 am ]]>
</Eventname>
  <Starttime>04-01-2006 02:00:00</Starttime>
  <Endtime>04-01-2006 05:00:00</Endtime>
- <Companyname>
  <![CDATA[ company 01 april 2006 - 2to5am ]]>
</Companyname>
- <Roomname>
  <![CDATA[ Inter continental resource rs 1 module X ]]>
</Roomname>
  <Createddate>03-22-2006 02:33:18</Createddate>
  <Groupevent>0</Groupevent>
  <Templatename>Inter continental resource rs 1 module X</Templatename>
</Event>
</Events>
```

Figure 398. Digital Signage XML file

CHAPTER 7.

Appendix

Virtual Resource Filtration over ResourceFinder

At the ResourceFinder, Virtual Resource(s) are also displayed like the Standard Resource(s). The Occupancy Information, along with the Conflict Error Messages against Virtual Resources is also displayed at the ResourceFinder.

In the case of Occupancy of Virtual Resources, two business rules are generally followed, which are discussed as following:

1. If you have booked a Virtual Resource against a timeslot, all the associated resources of this Virtual resource will be shown as Booked for that particular timeslot at the ResourceFinder
2. If a Standard Resource is booked for a specific timeslot, all the Virtual Resources in which this resource is being used will be displayed as booked for that particular timeslot at ResourceFinder.

You can control the Display and Occupancy of Virtual Resources at the ResourceFinder with the help of an Advanced Parameter named “**ResourceFinder.FilterVirtualResources**” which controls the Display, and thus the Occupancy Information of the Virtual Resources over the ResourceFinder.

This parameter “**ResourceFinder.FilterVirtualResources**” can have possible values of “1” or “0”. If the value of this parameter is ‘1’, then none of the Virtual Resource(s) would be listed at the ResourceFinder.

If this parameter is not created or is created with Blank or “0” value, the system would work as Normal, as described above.

Auto Arrange Functionality

Resource Central provides you with a facility with which you can automatically set the Status of the specific Line Items to “**Confirmed OR Arranged**” for a specified timespan. This functionality is executed with the help of a background service, controlled through 4 advanced parameters created in Resource Central.

All those Line Items that have the Status NEW, CHANGED and/or CONFIRMED, being serviced in some future reservations, will be changed to “**Confirmed OR Arranged**” when the above-mentioned service runs. In order to make use of this service, you would have to create the following 4 parameters (you already know that these parameters would be created at **RC Manager → General → Parameters** section).

Parameter	Description
AutoArrange.Enable	<p>If its value is “1”, then the service would be enabled and it will run at the time specified in the AutoArrange.Starttime parameter (default value is 235500 hours), and it would update the Status of all the Line Items ordered in servings related to the reservations of the number of days specified in AutoArrange.Days parameter (default value is 1 day).</p> <p>Moreover, it will only change the Status of those line items that previously have the Status of New, Changed and/or Confirmed.</p> <p>If its value is “0”, the service is Disabled. Also, the values of the parameters AutoArrange.Starttime and AutoArrange.Days will be ignored.</p>
AutoArrange.Starttime	<p>It will contain the start time at which the Auto Arrange service would run. The maximum value is ‘235958’ hours.</p> <p>If this parameter is not created, then the default value for this parameter is ‘235500’.</p>
AutoArrange.Days	<p>It will contain the number of past days upon which the Auto Arrange service would work on.</p> <p>If this parameter is not created, then the default value for this parameter is ‘1’.</p> <p>Example:</p>

	Suppose the current date of the system is 15 Oct 2007. Also, the user has set AutoArrange.Days = 5. Now when the service runs, it would update the status of all those Line Items that have been ordered before 10 October 2007 (15 Oct – 5).
AutoArrange.OrderStatus	It will contain the value of the status to be set. Possible values could be “Confirmed” OR “Arranged”. If this parameter is not created, created with Blank value or it has any value other than the above two, then the default Status would be “Arranged” However, please note that the status of item(s) that already have the status = Arranged cannot be set to Confirmed.

When the Auto Arrange Service has successfully run, you can verify that the Status of all the related Line Items (that previously had the Status of New, Changed and/or Confirmed) has been updated as per the configured values.

Reminder Email Functionality

Resource Central provides you with a facility with which you can remind the Organizers of the Reservations in the form of a Reminder Email. This Email works as a Reminder to the Organizer to inform that his/her meeting is approaching so he/she should remember all of the tasks (Orders, Servings, Extra Services) regarding that reservation.

The Reminder Email will be a simple email, with the basic information of the reservation. It will provide organizers with a link by the help of which they can go to the Order Form of the resource to create/update the order information for their reservation.

NOTE: the ‘Click Here’ link will not be available in those Reminder Emails which have been sent as per the Reservations of a Light Resource, satisfying the logic that order cannot be placed over a Light Resource.

The Reminder Email would be sent to all of the reservations that would meet certain criteria. The functionality of the Reminder Email is controlled through an Agent service, running on the SQL Server. This agent service is controlled by some parameters created in the Resource Central, whose description is as follows:

Parameter	Description
ReminderMail.Enable	<p>If the value of this parameter is “1”, the service would be enabled to run. This service will run only for the reservations of a single day. That is, all the organizers of those reservations whose Reservation Start time belongs to the same date will get Reminder Emails.</p> <p>The time at which this service is to run, will depend on the value of the ReminderMail.Starttime parameter (as discussed below).</p> <p>The date for which this service is to run will depend upon the value in the ReminderMail.Days parameter (as discussed below)</p> <p>If the value of this parameter is “0”, then the service would be Disabled. Also, the values of the other 2 parameters will be ignored.</p>
ReminderMail.Starttime	It will contain the start time at which the Reminder Email service would run. The maximum value could be “235958”. (Default value is “235500”)
ReminderMail.Days	<p>The value in this parameter will determine the date for which this service would run. (Default value for this parameter is “1”)</p> <p>Ex:</p> <p>ReminderMail.Enable = 1 ReminderMail.Starttime = 140000 ReminderMail.Days = 4 Current date = 03 April 2007</p>

Now the service will run on 3rd April 2007 at 02pm. It will generate Reminder Emails against all of the reservations whose Reservation start time lies at 7th April 2007 (current date + 4 = 7 April 2007)

NOTE: This service will not handle any of the Time Zone values (of Resource, user, or Application) and all the processing will be done as per the values of the reservations stored in the database

Canceling Resource Reservation on Reminder Email

Reminder Email also provides the ability to cancel resource reservation for a meeting. It only removes the designated resource from Resource Calendar; however, its respective meeting will remain in Organizer Calendar.

To do this, open the Reminder Email and you will see the following choice:

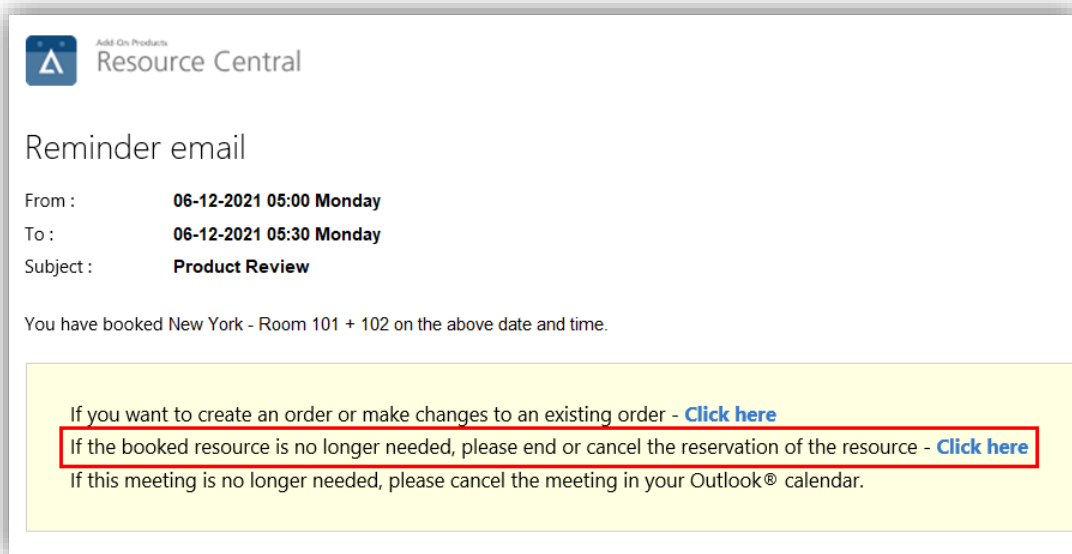

You will see the Cancel Reservation page, then you can click [**Cancel Reservation**] to confirm:

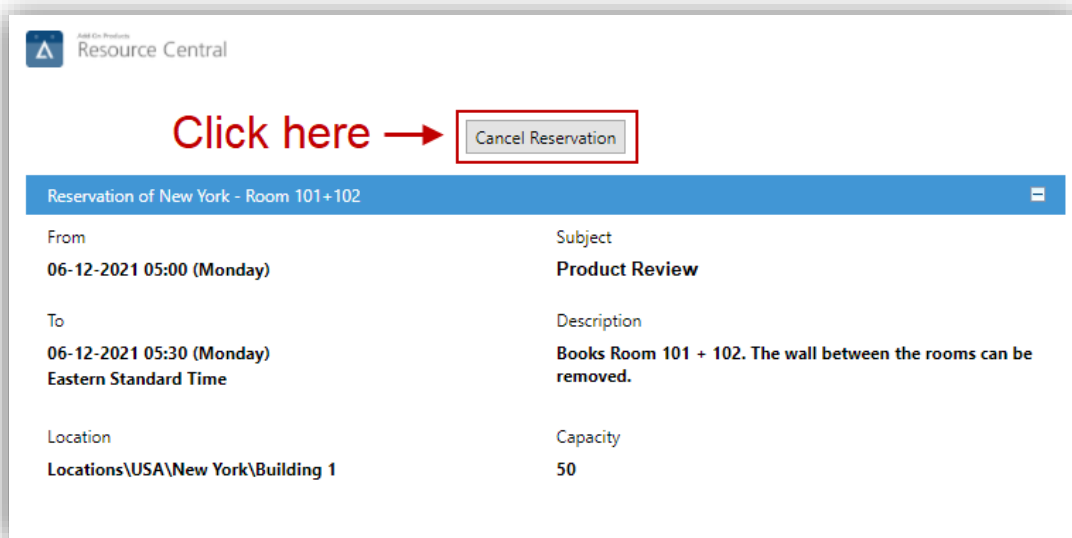

Finally, a notification page will appear confirming the cancellation.

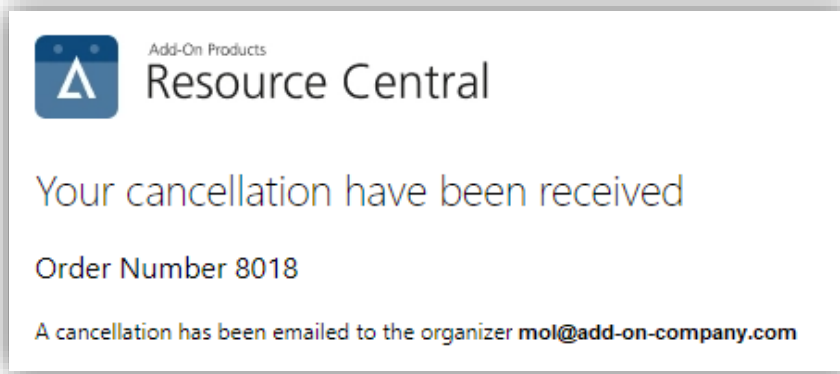

NOTE: When you cancel a resource reservation, that resource will be bookable at the cancelled time.

Item Quota Functionality

Resource Central provides you with the ability to limit the total amount of an item in all orders of the day. The limit number of items is called Quota. When the quota is reached, that item cannot be ordered anymore on that day. In case the quantity of the item exceeds the Quota, there is a pop up with a message that the item is closed for this date.

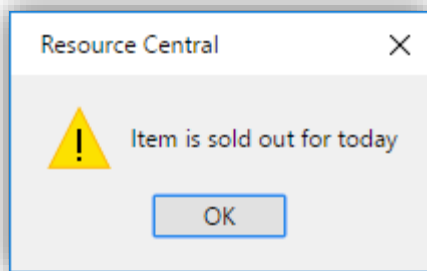

Figure 399. Exceeding quota message

The Quota value is specified/changed in the **Items** section of **Resource Central Admin Interface/Daily Tasks**.

This feature only works when users place order by **ResourceFinder/One Step Order** or **My Meetings**.

Parameters	Descriptions
ResourceFinder.UsingItemQuotaStatus	This parameter controls the Item Quota function. When the parameter has the value equal to "1", this function will be applied. Otherwise, when the value is not "1", or equal to "0", this function will not be applied. The default value of this parameter is "0"

Using Item Quota

In Admin interface, go to the **Daily Tasks/ Items** section and select an item in the Item list. From the **item detail view**, specify the item quota and save the record.

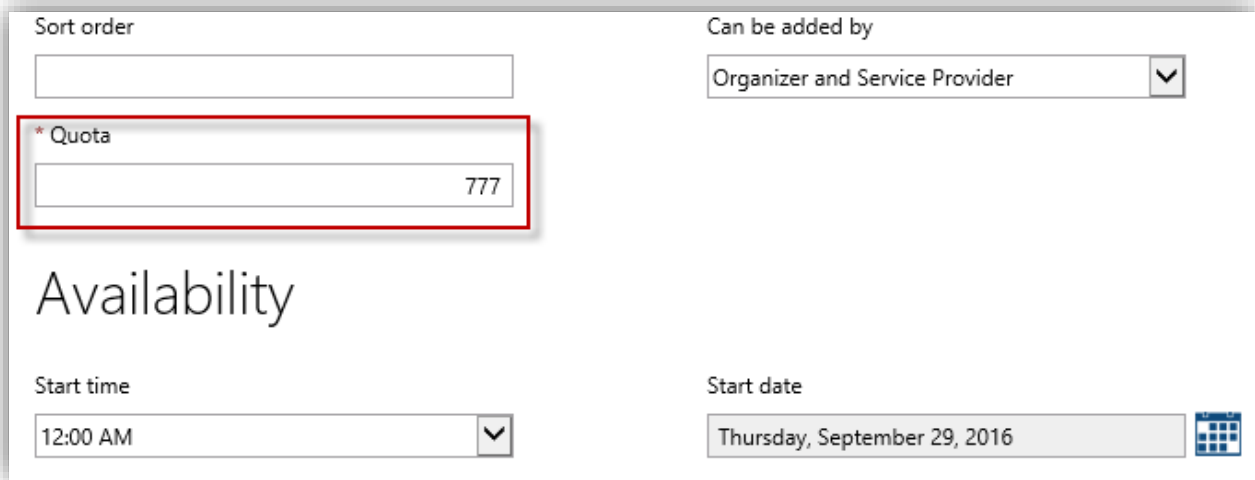
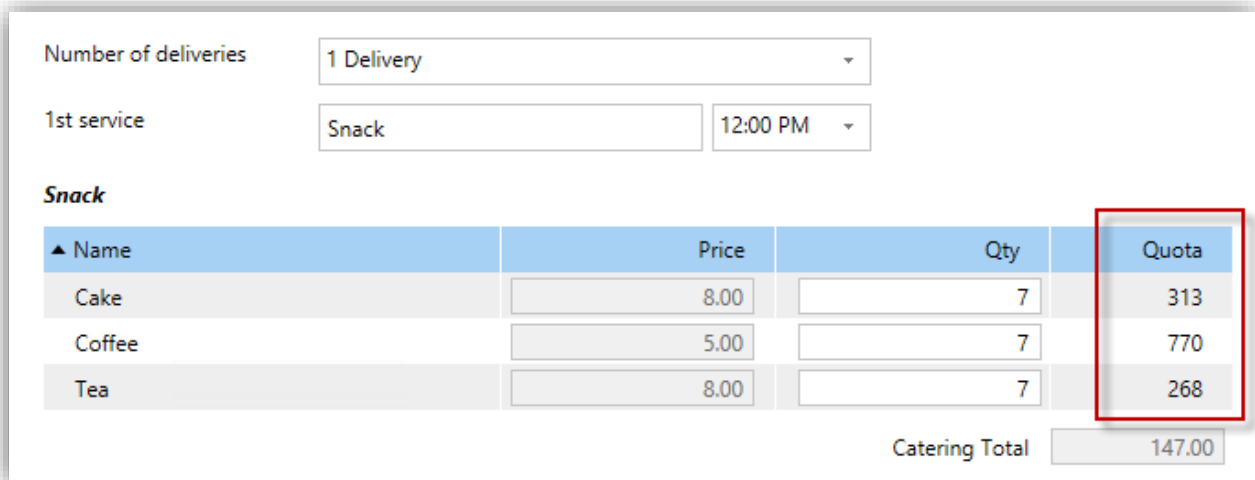

Figure 400. Order Item

Quota in ResourceFinder/One step order

1. Place an order:



Name	Price	Qty	Quota
Cake	8.00	7	313
Coffee	5.00	7	770
Tea	8.00	7	268

Catering Total 147.00

Figure 401. Quota of Order

User enters a quantity less than or equal to the quota and click **Send order**, the next time order this item, the quota value appear in the Order form is equal to the previous quota minus the quantity ordered last time.

For example:

In **Resource Central Admin Interface/Daily Tasks/Items**, set the Quota for Item Coffee to 100. Using **One Step Order**, place an order for Coffee with quantity being 10 as depicted below and then click **Send order**.

Serving 1			
▲ Name	Price	Qty	Quota
Cake	8.00	<input type="text"/>	150
Coffee	5.00	<input type="text" value="10"/>	90
Tea	8.00	<input type="text"/>	275
Catering Total			50.00

Figure 402. Quantity and Quota of Items

Afterward, place another order using One Step Order, the quota value appear next to quantity field is now 90. (New quota = previous quota – ordered quantity)

Serving 1			
▲ Name	Price	Qty	Quota
Cake	8.00	<input type="text"/>	150
Coffee	5.00	<input type="text"/>	90
Tea	8.00	<input type="text"/>	275
Catering Total			0.00

Figure 403. Quota of Item

- If user cancelled an order by Outlook, the New quota = previous quota – ordered quantity. For example, after an order for 10 quantity of item Coffee is placed, the quota is 90. Then that order is canceled, the value of quota would be $90+10=100$.
- If user enters the quantity exceeding the quota, there is a warning message inform user that the item is closed for this date and user cannot Send order as in the *'Exceeding quota message'* mentioned above.

Quota in My meetings

1. Book new reservation successfully, open My Meetings and select a reservation to place or edit an order:

Order - 7248

MEETING ROOM 002 ORDER

If you require extra services for your resource booking, please enter the number of deliveries, and fill out this form.

Number of deliveries: 1 Delivery

1st service: Serving 1, 07:00 AM

Serving 1

Name	Price	Qty	Quota
Cake	8.00		150
Coffee	5.00	10	90
Tea	8.00		275

Catering Total: 50.00

Figure 404. Quota in My Meetings

Enter a quantity less than or equal to the quota and click **Send order**, the next time order this item by My Meeting, the quota value appear in the Order form is not updated (it is still 51). This value is only updated when user place order using **ResourceFinder/One Step Order**.

2. If user cancels an order by Outlook or My Meeting, the **New quota = previous quota – ordered quantity**.
E.g.: After an order for 10 quantity of item Coffee is placed, the quota is 90. Then if that order is canceled, the value of quota would be 90+10=100.
3. If user enters the quantity exceeding the quota, there is a warning message informing user that the item is closed for this date and user cannot Send order as in in the *'Exceeding quota message'* mentioned above.

Quota functionality in reservation with changed date

In case organizer changes date of a reservation with order, there are 2 situations:

1. **Quantity of at least one item in the order exceed the quota:**
 - Order will be cancelled and only reservation is moved to the new date.
 - Cancelled order email is sent to organizer and service provider.
 - Changed reservation email is sent to organizer.
2. **Quantity of all items in order are available:**
 - Order and reservation are moved to new date successfully.
 - Only Changed reservation is sent to organizer and service provider.

Addition of Account Number text box to Order Form

This functionality provides the ability to add a text-box property named “Account Number” into an order form of a reservation. So that the meeting organizer can manually input an account number in order form to ensure that the invoice is sent to the appropriate department.

Follow these steps:

Step 1. In RC backend, go to **System → Parameters**, click **[New]** to create a new parameter. Enter “**Account.Number**” into “**Key**” field and “**propAccountNumber**” into “**Value**” field (see **RC Parameter Guide** for more details about this parameter):

Parameter Details

* Key
Account.Number

Value
propAccountNumber

Description

For more details about this parameter, please refer to **RC Parameter Guide**.

Step 2. In RC backend, go to **Designer → Properties**, click **[New]** to create a new property. Enter “**_propAccountNumber**” into “**Number**” field and “**AccountNumber**” into “**Text**” field:

Property Details

* Number
_propAccountNumber

* Text
AccountNumber

Tip

Description

Sent to
All

Sort order

Required
 Yes No

Locked
 Yes No

Step 3. Go to **Designer → Forms**, click **[New]** to create a new form. Enter the name for this form (e.g., AccountNo), then click **[Property]** icon on the tool ribbon to insert a property. The following window shows up:

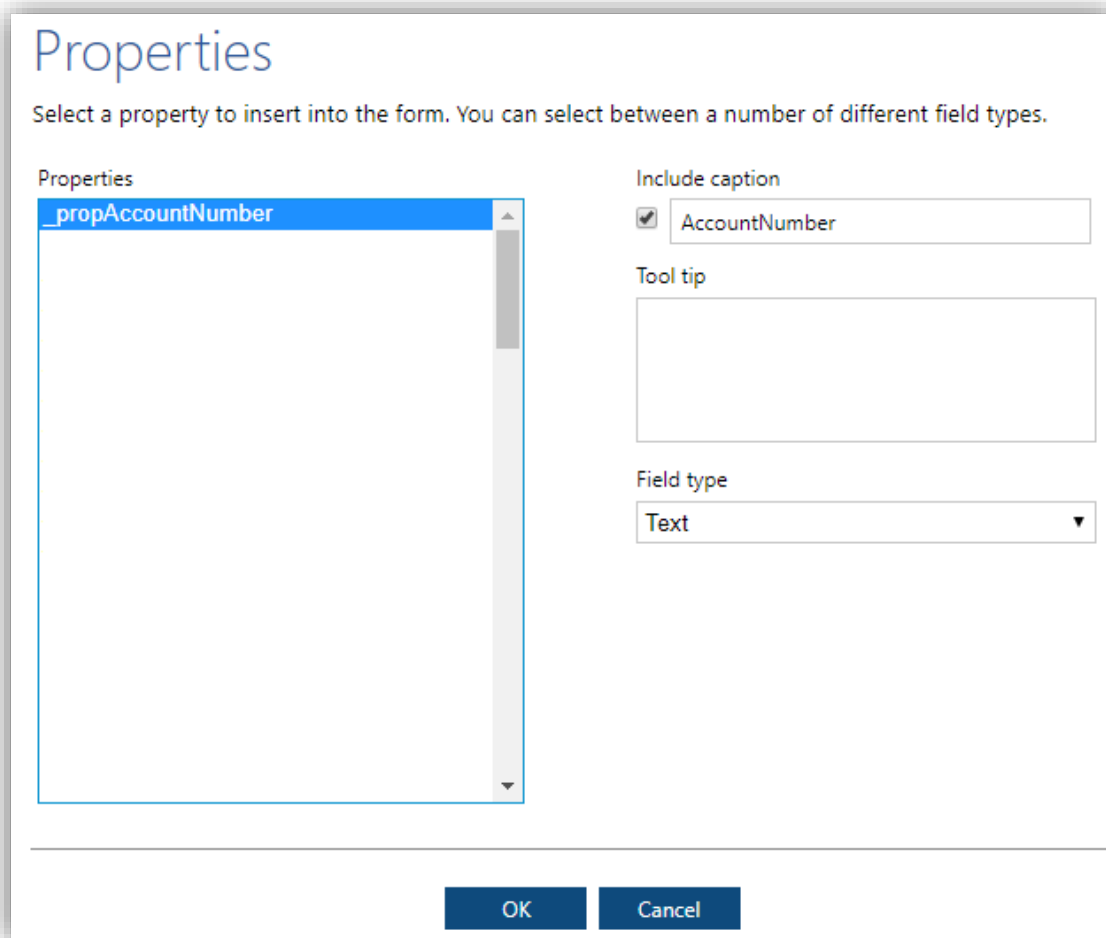

Step 4. Select the property you created in the previous step, and **Text** or **Text area** for **Field type**. Then click **[OK]**, the property is inserted into the form as in the following figure:

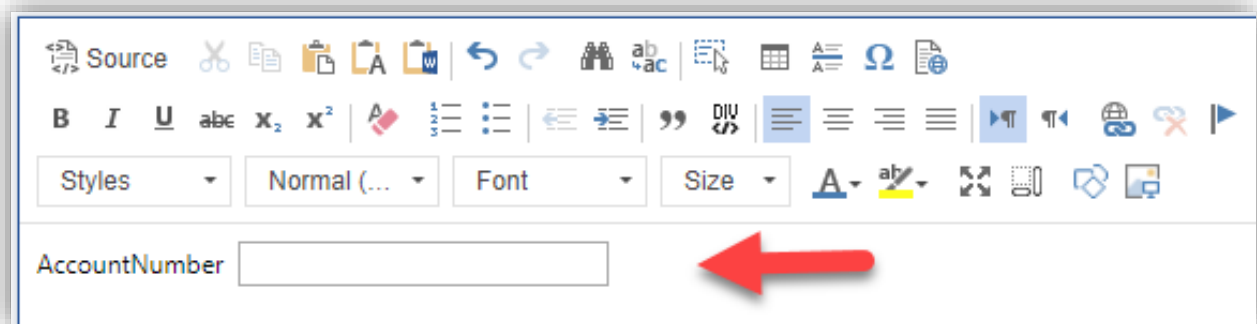

Click **[Save]** and proceed to the next step.

Step 5. Now you need to add this form into a resource in order that if this resource is booked for a reservation, the property you have created is available on order form related to this resource.

In RC Backend, go to **Designer → Resources**. Click on the resource to which you want to add the property you have created; its details are displayed. In “**Form**” field of “**Order Flow Properties**” section, select the form you have created (in this example, it is “**AccountNo**”):

Form

AccountNo

Shared order form

[Empty dropdown]

Tentative order

Yes No

Click [**Save**] to finish.

From now on, whenever you book a reservation in the resource you selected in **Step 5**, the order form related to this resource always has “**AccountNumber**” field in “**Property**” section.

Order Form | Delete Order | Assistant

Function | Order Form

Properties_tHaO

Trolley [Input field]

AccountNumber [Input field]

Save | Delete

Meeting Organizer

Figure 405. Order Form

If you enter an account number then click [**Save**], this account number will be remembered so in the next time when you type the first digit of the account number, it will show up for you to select:

AccountNumber 0

0123456789

Figure 406. Saved account number

If you enter/select an account number then click [**Delete**], this account number will be removed and when you type the first digit of that account number, it will look like in the following figure:

The screenshot shows a web form with a label 'AccountNumber' and an input field containing the letter 'c'. Below the input field, a dropdown menu is open, displaying the text 'Not Found'. There are also some faint, partially visible buttons below the dropdown.

Figure 407. Account number removed

NOTE: The account number you enter must be positive integer with at least 10 digits, and no space is allowed between digits.

Print order with signature line

Resource Central provides user the ability to add a signature line in the left bottom of the printout when user prints an order in **Daily tasks\Order\Order Detail**.

Parameters	Descriptions
Order.Print	This parameter provides the ability to generate a signature line in the left bottom of the printout when user prints an order in Daily tasks\Order\Order Detail . When the parameter has the value equal to "1", this function will be applied. Otherwise, when the value is not "1", or equal to "0", this function will not be applied.

The printout would have a signature line as depicted below:

The screenshot shows a printout titled 'Order Details' for the date 10/3/2016. It includes the following information:

- Order number: 5
- Name: **Serving 1**
- Subject: **Press Conference**
- Resource: **Meeting Room 002**
- Start time / End time: **01-10-2016 03:00 AM - 01-10-2016 03:30 AM**
- Organizer email: **Administrator [Administrator@rc37.com]**
- Last Updated: **29-09-2016 12:19 PM**

Below this information, it says 'Serving 1 at 03:00 AM' and displays a table of items:

Item	Status	Quantity	Consumed qty	Sales price	Sum
Cake	New	1		8.00	8.00
Coffee	New	2		5.00	10.00
Tea	New	2		8.00	16.00
				Total	34.00

At the bottom of the printout, there is a URL: <http://192.168.1.122/ResourceCentral/Admin/OrderDetail?orderId=5¤tDate=10/01/2016&isPrint=true> and a page number '1/1'.

Figure 408. Order Detail (print view)

Location handling when booking resources

You may have also noticed that a new header “Location” has been added in the summary screens at **RC Admin → Daily Tasks → Reservations & My Meetings**, as highlighted in the figure below:

From	To	Resource	Subject	Organizer	Is Recurring	Location
03:00 AM	03:30 AM	Meeting Room 002	Press Conference	Administrator@rc37.com (Administrator)		Locations\Europe\Germany
05:00 AM	05:30 AM	Meeting Room 002	Project Meeting	Administrator@rc37.com (Administrator)		Locations\Europe\Germany
07:00 AM	07:30 AM	Meeting Room 002	Project Meeting	Administrator@rc37.com (Administrator)		Locations\Europe\Germany
10:30 AM	11:00 AM	Meeting Room 004	Press Conference	Administrator@rc37.com (Administrator)		Locations

Figure 409. RC Admin → Daily Tasks → Reservations summary screen

When you book a Resource, in the RC system at the summary screens of **RC Admin → Daily Tasks → Reservations** (and in **My Meetings**), a value will also be displayed against this reservation under the head of “Location”.

This value is taken from the ‘Location’ field in the New Appointment window. When you are placing an appointment, you must have noticed that the ‘Location’ field contains some value(s) in a specified format.

The extraction of the value from the ‘Location’ field in the New Appointment window depends on how many Standard and/or Light Resource(s) are there in the ‘To’ field of the New Appointment window. The Resource Names along with their Locations are also displayed in the ‘Location’ field of the New Appointment window, each separated by a semi-colon (;).

Project Meeting - Meeting

FILE MEETING INSERT FORMAT TEXT REVIEW

Delete Calendar Appointment Scheduling Assistant ResourceFinder Cancel Invitation Address Book Check Names Response Options

Actions Show ResourceFinder Attendees Options

Show As: Busy

Reminder: 15 minutes Recurrence

You haven't sent this meeting invitation yet.

To... Ps1; Ps2

Subject Project Meeting

Location Meeting Room 201(Locations\USA\New_York\Fifth_Avenue);Small Meeting Room 103(Locations\USA\New_York\Freedom_Street)

Start time Sat 10/29/2016 12:00 AM All day event

If you navigate to the reservation date on My Meetings, you will see that the extracted value is being displayed against the Reservation, under the ‘Location’ head (as shown below):

From	To	Subject	Resource	Location	Orders	Is Recurring
3/1/2017 10:00 PM	3/1/2017 10:30 PM	Project Meeting	Meeting Room 201	Locations\USA\New_York\Fifth_Avenue	✓	✓
3/1/2017 10:30 PM	3/1/2017 11:00 PM	Project Meeting	Small Meeting Room 103	Locations\USA\New_York\Freedom_Street	✓	✓

Figure 410. My Meetings

As you can see that the value in the 'Location' field of New Appointment window is in the format "**Resource Name1(<Location path>); Resource Name2 (<Location path>)**". This complete string will be parsed, and the name of the Standard Resource will be extracted from this string.

Assumptions:

1. If you manually edited the value in the 'Location' field of the New Appointment window and its format is disturbed, then No Parsing can be done, and the complete string value will be displayed.
2. In case that you are placing a reservation over a Light Resource with an Anonymous resource, then it is strongly recommended that the value in the 'Location' field of the Appointment window should not have any of the Resource Names that have been defined in the RC system (Resources can be found at **RC Admin → Designer → Resources** section).

This can be explained with an example:

- Suppose at **RC Admin → Designer → Resources**, we have 3 resources namely Resource1, Resource2 & Resource3. Resource3 is a Light Resource while the other two are Standard Resources.
- Open the New Appointment window in the Outlook, navigate to the ResourceFinder, and select 'Resource3' and then click the 'Save and Close' button. You will be back in the same Appointment window. Now, in the 'To' field of the Appointment window, enter an anonymous email such as 'abc@hotmail.com'.
- Now, you have to explicitly edit a value in the 'Location' field of the New Appointment window. Whatever you edit in that field will be taken up by the system and will be displayed at the respective areas.

Constraints:

As you know that when we come back to the New Appointment window, after selecting the resources from the ResourceFinder, the value displayed in the 'Location' field of the New Appointment window is in the following format: **Resource Name1(<Location path>); Resource Name2 (<Location path>)**.

This above format is controlled via an advanced parameter "**Addin.TrimLocation**". If the value of this parameter is "1", then the following format will be displayed in the "Location" field of the New Appointment window: **Resource Name1; Resource Name2**.

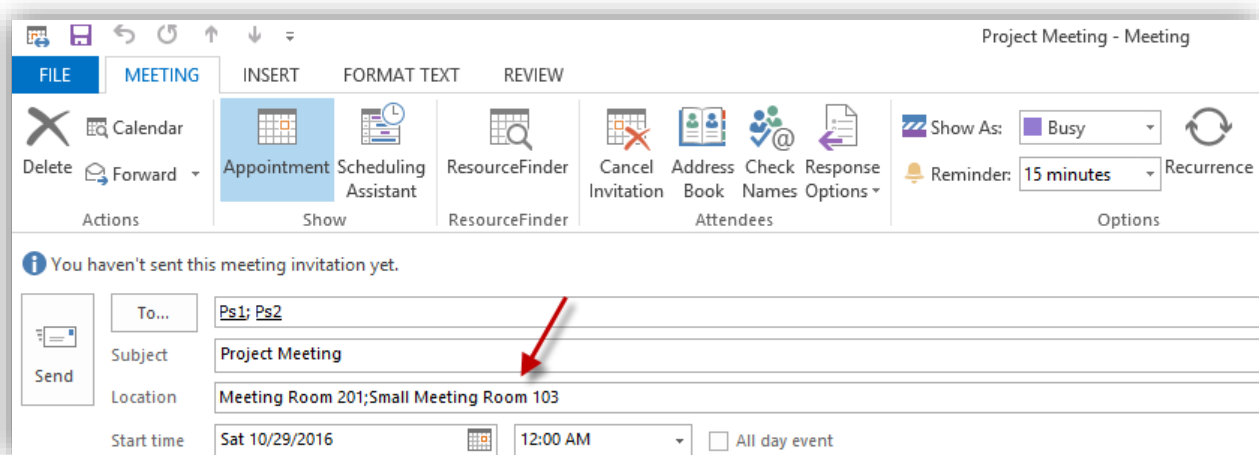

For more information regarding this parameter, refer to **Resource Central Parameter Guide**.

My Meetings Stand Alone Page

In order to enable the integration of Resource Central with other systems, Resource Central provides a stand-alone page which provides the user with an overview and access to all booked meetings and associated services. This will enable an outside user to access and use the information as required, without actually requiring to login the RC system.

To enable this feature, create a new parameter:

Parameters	Descriptions
MyMeeting.DirectAccess	This parameter controls the My Meetings Stand Alone Page function. When the parameter has the value equal to "1", this function will be applied. Otherwise, when the value is not "1", or the parameter is not created, this function is disabled.

The page can be accessed by hitting the following URL in the browser:
[http\(s\)://<ServerName>/<VirtualDirectoryName>/MA/Frontcontroller.aspx?user=<OrganizerEmail>](http(s)://<ServerName>/<VirtualDirectoryName>/MA/Frontcontroller.aspx?user=<OrganizerEmail>)

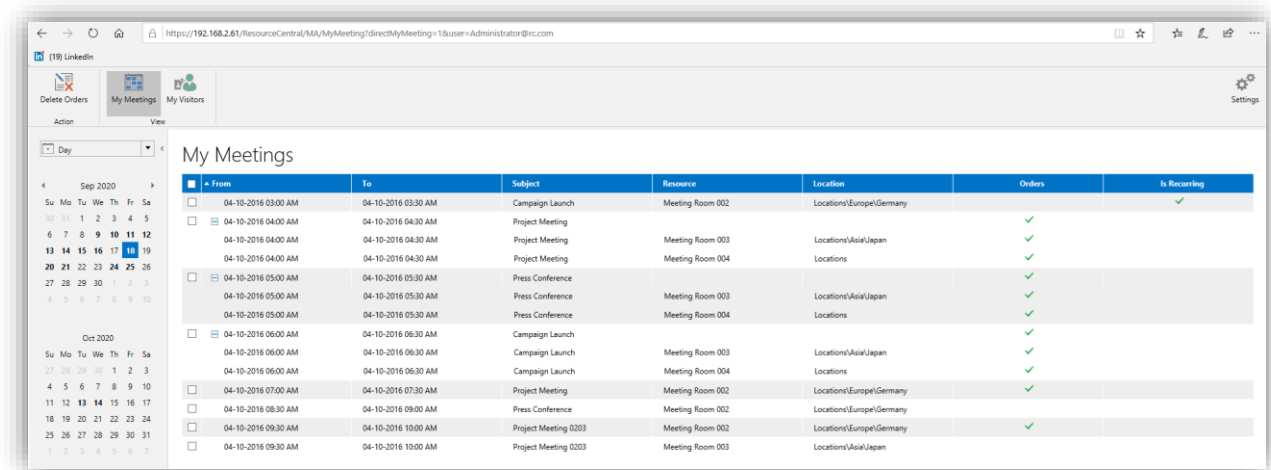

Figure 411. My Meetings Stand Alone Page

The displayed page is nearly a replica of My Meetings. It will display all booked meetings and associated services.

Assumptions and Constraints regarding My Meetings stand-alone page:

- All the booking/reservation date/time will be displayed as per the Application Time Zone. Impact of the Resource Time Zone, if specified, will be ignored.
- This page would always be displayed in the Application Language

Tree structure

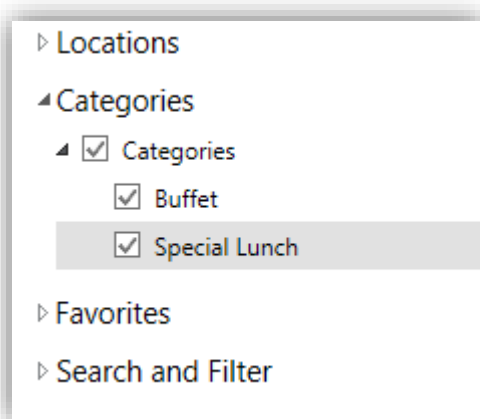

Access to all functions in Resource Central is controlled by the tree structure in the left pane of the application screen. The tree consists of a number of nodes and child nodes.

Context menu

Root Nodes (Application Nodes)

Those nodes that have been created as part of the application will be considered as Root Nodes. When you right click on any root node, a context menu will appear, and depending upon your access rights, you will have all or a part of the following context menu

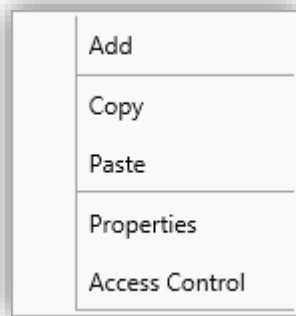

User created Nodes

All the other nodes except that of the root nodes will come under this category. They may have been created by the users, depending upon their rights. When you right click on any of these nodes, a context menu will appear, and depending upon your access rights, you will have all or a part of the following context menu.

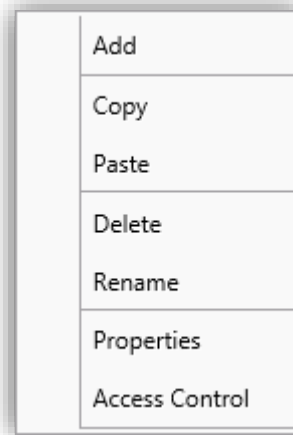

Figure 412. Context Menu

Tree Node functions

Both of the context menus contain the following “**Tree Node**” functions.

Add

Add a new node as a **sub node** of the current selected node.

The "Add new location" dialog box contains the following fields and controls:

- Caption:** A text input field.
- Description:** A text area with a vertical scrollbar.
- Key:** A text input field.
- Icon Key:** A text input field with a blue ellipsis button to its right.
- Calendar:** A dropdown menu currently showing "Default Calendar".
- Extra ID 1:** A text input field.
- Buttons:** "Save" and "Cancel" buttons at the bottom.

Figure 413. Node Properties window



Field	Description
Caption	Name of the node.
Description	A short description of the node.
Key	A unique key for identifying the node (It can be empty).
Icon Key	Select a key from the lookup for a custom icon. If left empty, the default is Document Icon.

Copy

Makes a copy of the **current** node and **child nodes**, and places that copy as text on the clipboard. Child nodes are represented with one or more leading tabs depending on the placement in hierarchy.

Paste

Creates one or several nodes depending on the clipboard content.

Delete

Deletes the current selected node and its sub nodes.

Use the Delete function with caution! If you by mistake delete any user created nodes, you will not be able to access it again. Use the **Access Control** to limit access to given nodes.

Rename

Changes the caption of the selected node. When you click RENAME, the same window appears as discussed in the Add function above, with the current caption of the selected node.

Properties

Using properties, you can **edit** the fields related to the selected node. When you click [**Properties**], the same window appears as discussed in the **Add function** above.

Access Control

Using Access Control, you can **limit access** to the system based on the defined **security** roles.

Logoff

All across the application, you will see a [**Logout**] button at the right corner of the application screen. Whenever the user clicks this button, the system logs the user out of the application and takes him/her on the **Login** Screen.

Standard Buttons

All across the application in the right pane, you will see the following buttons on nearly all the screens:

Toolbar Buttons	Description
Back	Takes you to the most recent screen that you have visited
Print	Takes you to the Printing Preferences page so that you can take the print of the current page

Access Control

Changing Access Control Rights

Using the context menu function **Access Control (that can be opened by right click on some tab)** you will get access to a **matrix** representing the current access rights for the selected node.

Remember that only **Security Roles** are **eligible** for Access Control. That is, only those roles defined as Security Roles at **Resource Central Admin** → **Security** → **Roles** will be displayed in this window.

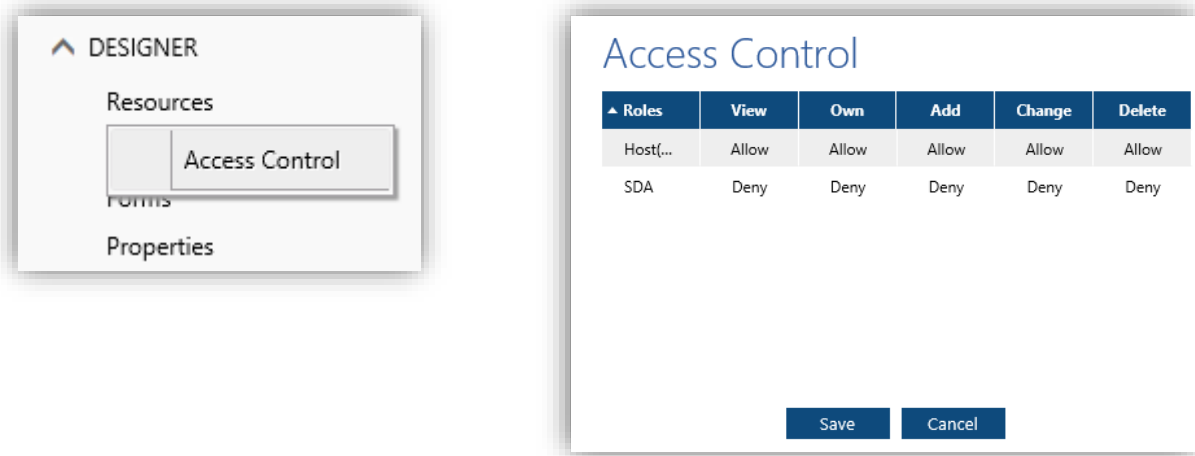

Figure 414. Access Control window

Access Control is divided into 5 areas:

- View
- Own
- Add
- Change
- Delete

For a given combination of a role and one of the rights, you can set “**Allow**” or “**Deny**”.

When you click **save**, the current selected node and its sub nodes are **updated** with the chosen **ACL** combination.

Determining Access Control Rights

A given user’s rights are determined by the system by checking which roles a user belongs to. If “**Allow**” access is found for one of the roles a user belongs to, then access is allowed.

Also, the impact of the rights of **ACL** also applies to the toolbar buttons in the right pane of the application screen. That is, if **Delete = Off** in ACL, then the [**Delete**] button at the toolbar in the right pane of the application screen would also be **DISABLED**.

Workflow

The workflow in **RESOURCE CENTRAL** is initiated by an appointment being made in an **Exchange calendar**.

Event: New appointment in Exchange Calendar

Whenever an appointment is made in a resource calendar, a message will be sent to **SQL Service Broker Queue** with information about the **resource’s name**, **start** and **end time** and **status**. A notification is then sent to RC Synchronize Service to create email content which will be sent to organizer and Service Provider(s).

First time information about a certain appointment is received by **RESOURCE CENTRAL**, a copy of the appointment will be stored in the database.

The **copy** will only be stored when the status is **BUSY** or **OUT OF OFFICE**.

This is considered to be a **NEW RESERVATION**. An **e-mail** is then sent to the organizer of the appointment. The **e-mail** contains a link to an **order form** generated by the **RESOURCE CENTRAL** web server.

Event: Appointment changed in Exchange Calendar

Whenever information on an appointment is changed in **the Exchange Calendar**, the following will happen in **RESOURCE CENTRAL**.

Status changes from BUSY/OUT OF OFFICE to FREE/TENTATIVE

The order will be **Inactive** and **no e-mail** will be sent to the organizer and responsible roles/persons.

Status changes from FREE/TENTATIVE to BUSY/OUT OF OFFICE

In Exchange Server SP 2 – Roll up 2 or later version, if status of an appointment was **FREE/TENTATIVE** in **First time** information and afterward it is changed to **BUSY** or **OUT OF OFFICE**, the appointment is then considered as a **NEW RESERVATION**.

An **e-mail** is then sent to the organizer of the appointment. The **e-mail** contains a link to an **order form** generated by the **RESOURCE CENTRAL** web server.

Start / end time of appointment changes

RESOURCE CENTRAL will check that the new start time does not conflict with any rules set to prevent orders being received later than a specified time before start of the appointment. If a new start time violates a rule, **RESOURCE CENTRAL** will **decline** the order, and send **an e-mail** to both the **organizer** and those who are in **charge of the resource**.

If **no conflicts** are found, **e-mail** will be sent to the **organizer** and **Responsible role/person** stating that a change in the order has been made.

Event: Appointment deleted in Exchange Calendar

If an order previously was sent to **RESOURCE CENTRAL**, the order will be **deleted**, and **e-mail** will be sent to the **organizer** and **responsible role/person**.

If **no order** exists for the given reservation, a **Cancel Reservation email** is sent only to the **Organizer**.

Event: User clicks link to order form

If an order previously was made for a given reservation, the user will be able to change that.

Event: User clicks “send order”

The order will be sent to **RESOURCE CENTRAL** Database.

If order is successfully sent from ResourceFinder, user will be redirected to the Resource Overview screen view.

If order is successfully sent by ways other than ResourceFinder (My Meetings, email etc.), a message will be shown as the figure below:

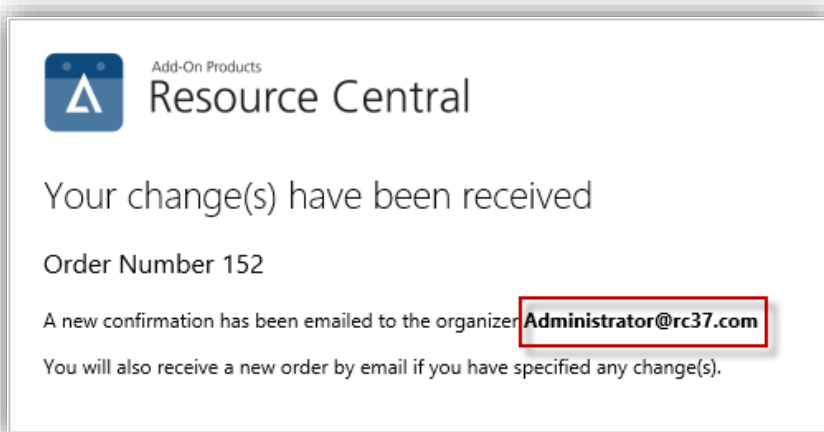

Figure 415. Organizer Email Address

Also, **RESOURCE CENTRAL** will then send **e-mail** to the **organizer** and **Responsible role/person** with details about the order.

Event: Resource Service Provider clicks “decline order” link

In the **e-mail** order sent to **Responsible role/person**, a **link** is provided. Clicking that link will **direct** him/her to a page showing **details of the order**. If the **Responsible role/person** wants to **decline** some or all of the items in the order, he/she can do it either by making the quantities **Blank** or making the quantities **0**. At the end, he/she would also be prompted for a **comment**.

If the order or any one of the items in the order is **declined**, **e-mail** will be sent to the **organizer**.

If the order or some items in an order have been **previously declined**, those orders or those items would not be shown at all.

If the order has been **previously deleted** (by deleting the appointment in Exchange) – a message stating this situation will be shown – and no further actions for that order can be made.

Event: Book a reservation on a resource that has delegate function

In this situation, after the reservation is created, it is granted “**Tentative**” status, and orders cannot be booked for it.

Emails will not be sent until the Delegated User accepts the reservation in the resource calendar.

After the reservation is accepted, its status is changed to “**Busy**”.

Guest house booking

This feature is used for the visitors to book their room, and when they receive the confirmation email, there must be necessary information related to their booking in the email content, e.g., Guest name, Start time/End time of stay, Room Name/Number, Door PIN code, etc.

In order to setup this feature, follow these steps:

Step 1: Create the following parameters:

Key	Value
OrderForm.FirstName.PropName	FirstName
OrderForm.LastName.PropName	LastName
OrderForm.ExternalEmail.PropName	ExternalEmail
OrderForm.PINCode.PropName	PINCode
OrderForm.Message.PropName	Message
OrderForm.RoomName.PropName	RoomName
OrderForm.Message.Value	User can input any message here

NOTE: The message entered as value of **OrderForm.Message.Value** parameter will be inserted automatically to Message field on Order Form. And Organizer and Service Provider can change content of this message from **Message** property (that will be created after this step) and **Message** parameter.

Step 2: Create the 6 properties in correspondence with the parameters created in Step 1.

To create the correspondence and connection between parameters and properties, the value of parameter must be similar to what you enter to the “Number” field of the property. Therefore, the properties that need to be created are: FirstName, LastName, ExternalEmail, PINCode, Message and RoomName.

Step 3: Insert all properties created in Step 2 into one form.

NOTE: FirstName, LastName, ExternalEmail, PINCode and RoomName are required properties. Message field is optional.

Step 4: Associate the form created in Step 3 to a resource.

After all these steps, if an order is booked and sent to customer emails, the confirmation emails will be sent to the customers with the following content:

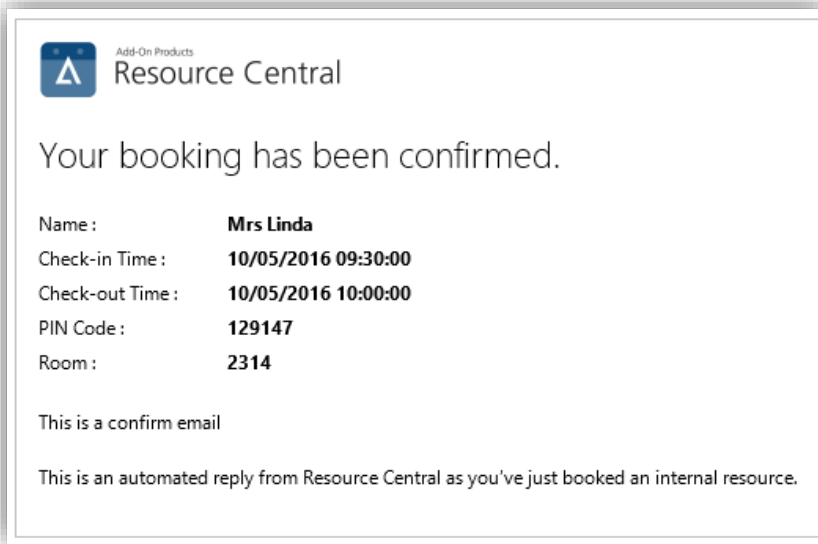

Figure 416. Confirmation email sent to customers

NOTE: You can configure subject of the confirmation email by a parameter named “OrderForm.ExternalEmail.Subject”. Refer to *RC Parameter Guide* for more details.

Trouble shooting

The recommended steps to trouble shoot Resource Central is listed below:

1. Validate that resource reservations are auto accepted
2. Check that license is valid
3. Validate communication between Web and Exchange
4. Check that a resource has been created and registered
5. Check that reservations are tracked
6. Check that mail content can be produced
7. Check that organizer receives e-mail
8. Check that orders can be sent

Steps for Administrator to set up Roles, create Properties and Design Shared Order Form for Shared Order 1.0 feature

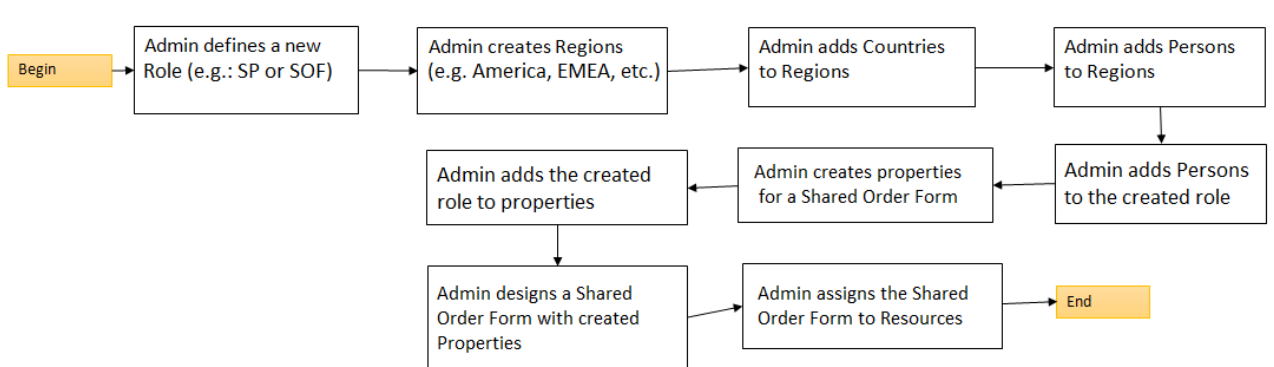

Figure 417. Shared Order 1.0 establishment work-flow

Define a new role (e.g., SP for SOF)	See " Roles " section
Create Region, add countries and persons to created region	See " Regions " section
Add persons to the newly created role	See " Roles " section
Create properties for Shared Order Form and add the newly created role to created properties	See " Properties " section
Design a Shared Order Form with created properties	See " Forms " section
Assign the Shared Order Form to Resource	See " Resources " section

How to change language and password in RC backend

As a user, you can change your own password and language by hovering your mouse on the [**Settings**] icon next to the username, at the upper right corner of the screen:

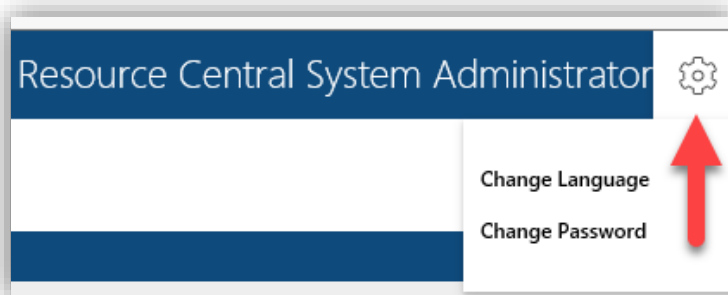
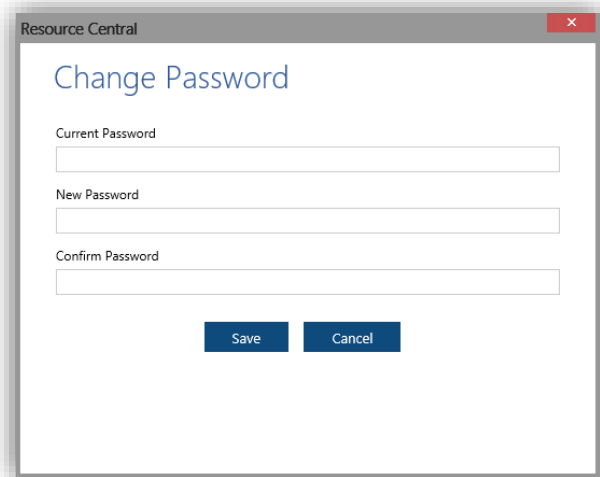
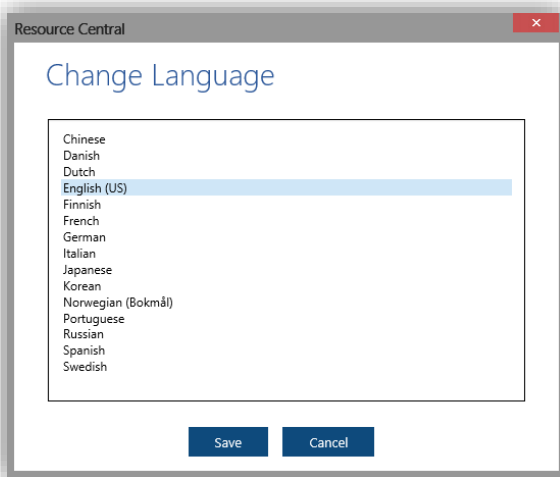

Figure 418. Change personal settings

Select Change Language to go for your preferred language, or click Change Password to reset password for your own account:

Change language

Change password



Then click [**Save**] to finish after making the changes.

Introduction of new System account and SysAdmin role

To facilitate Single Sign-On, a new system account is introduced. This account is granted a new role which has full permissions in RC system: SysAdmin role. The following sections are detailed description about this role and the new account.

SysAdmin role

This role has the following features:

- Users in SysAdmin role have full permissions of RC system
- SysAdmin role is not displayed in Access Control List and Relations window
- SysAdmin role cannot be deleted from the system
- SysAdmin role is not used for Items/Properties as a responsible role
- SysAdmin role can only be assigned to a new person by System account

System account

This account has the following features:

- System account is displayed in the Persons list as other accounts, but it is unchangeable and cannot be deleted from the system
- System account is a member of SysAdmin role
- SysAdmin role is fixed for System account and undeletable
- Only a System account can assign SysAdmin role to other persons
- System account is not used for Items/Properties as a responsible account.

Password recovery

NOTE: This function is not available if Single Sign-on is turned on.

This feature allows you to reset your password. Simply click on the **[Forgot Password]** button on Login panel. The following panel shows up:

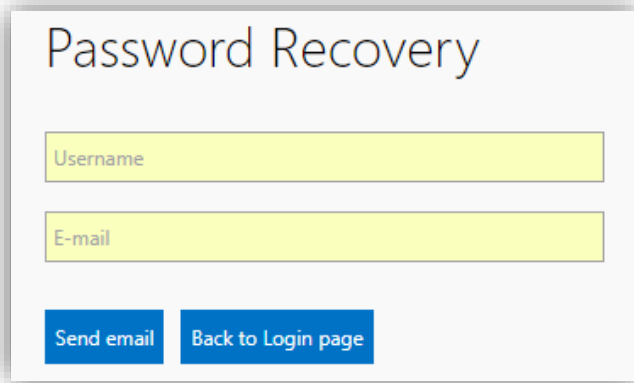

The screenshot shows a web panel titled "Password Recovery". It contains two text input fields: "Username" and "E-mail". Below these fields are two blue buttons: "Send email" and "Back to Login page".

Figure 419. Reset password panel

You need to enter username and email to the textboxes, then click **[Send email]**. If the inputs are correct, you will receive this notice:

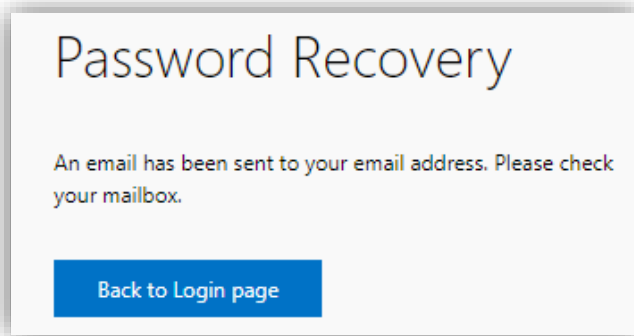

The screenshot shows the same "Password Recovery" panel, but the input fields are now empty. A message is displayed: "An email has been sent to your email address. Please check your mailbox." Below the message is a blue button labeled "Back to Login page".

Figure 420. Email sent confirmation

After this, an email is sent to the email address that you entered. There is a link to reset your password inside that email. Click that link and you will be redirected to RC login page with the following panel:

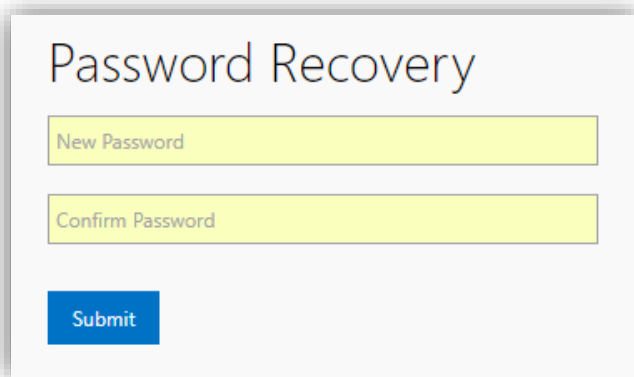

The screenshot shows the "Password Recovery" panel with two text input fields: "New Password" and "Confirm Password". Below these fields is a blue button labeled "Submit".

Figure 421. Finish password recovery process

Now you can reset your password by typing the new password, then confirm and click **[Submit]** to finish.

Text customization in Resource Central

Resource Central is a multi-language product. It means that the UI language can be switched to a language among a certain set of supported language. PO files are used to Export/Import the localized languages from/to Resource Central.

The PO file contains multiple similar sections, each of which consists of 4 lines as described below:

Line	Meaning	Description
#.	Note/Remark	A note or remark to instruct the translator what to do with this specific text, or it can be URL to the image where the text appears (must not be changed)
msgctxt	Context	Context code to identify where the text is located (must not be changed)
msgid	English text	US-English string which is used as an ID by the software (must not be changed)
msgstr	Localized text	Text translated or modified from the US-English text

If, for example, you are going to localize the software texts into German, this is a specific section in the PO file:

Before:

```
#. "http://pic.add-on-development.com/DeleteTreeNode_Confirm.png"
msgctxt "~/Views/Default/ContextMenu.cshtml"
msgid "Do you really want to delete the tree node 'NODE' and all the nodes below it?"
msgstr ""
```

After:

```
#. "http://pic.add-on-development.com/DeleteTreeNode_Confirm.png"
msgctxt "~/Views/Default/ContextMenu.cshtml"
msgid "Do you really want to delete the tree node 'NODE' and all the nodes below it?"
msgstr "Möchten Sie das Element 'NODE' mit allen untergeordneten Elementen wirklich löschen?"
```

Sometimes, the wording of a message/text might need adjustment to your organization's needs or maybe be incorrect and you want to change it. Resource Central supports you customizing the system texts, and below is a description on how to change texts pr. language in Resource Central Backend, ResourceFinder & MyMeetings and in emails. Your changes to the translation will be remained even after upgrades.

Custom localization for RC Backend

Follow these steps to change a text for RC backend:

1. Go to **Localization** folder
(By default, it is located at: *C:\inetpub\wwwroot\ResourceCentral\App_Data\Localization*)

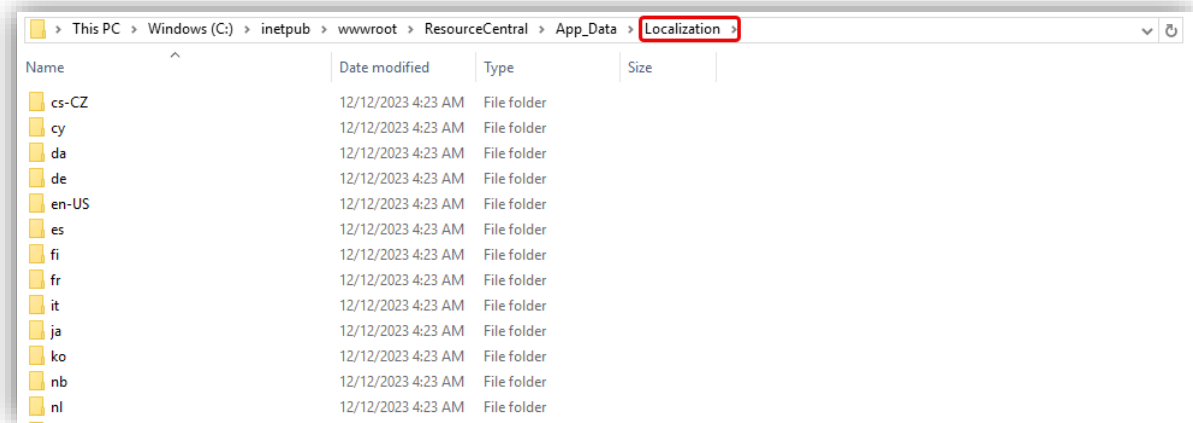

2. Open the specific language folder that you want to make change.
3. Open the PO file (root.po) in that folder.
4. Search for the text that you want to modify and copy the whole block of the text.

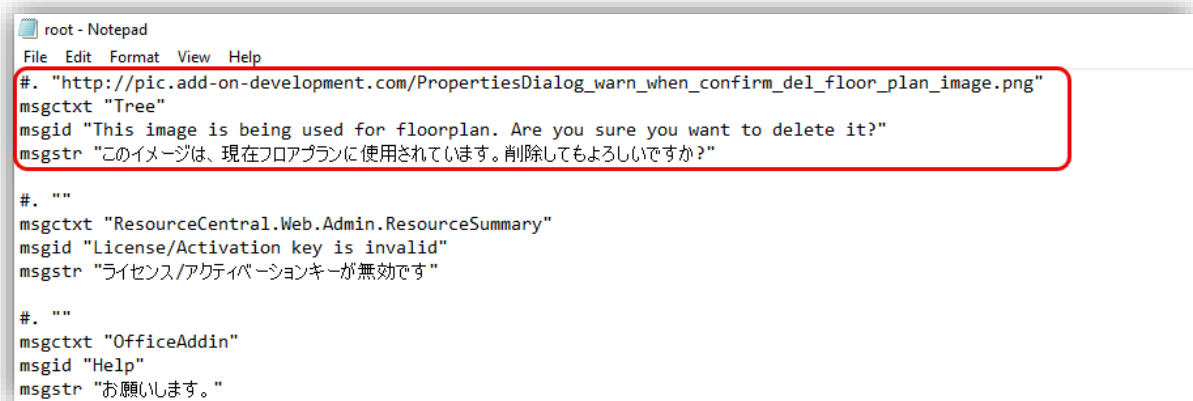

5. Go to **CustomLocalization** folder and find the right language folder.
(By default, it is located at: *C:\inetpub\wwwroot\ResourceCentral\App_Data\CustomLocalization*)

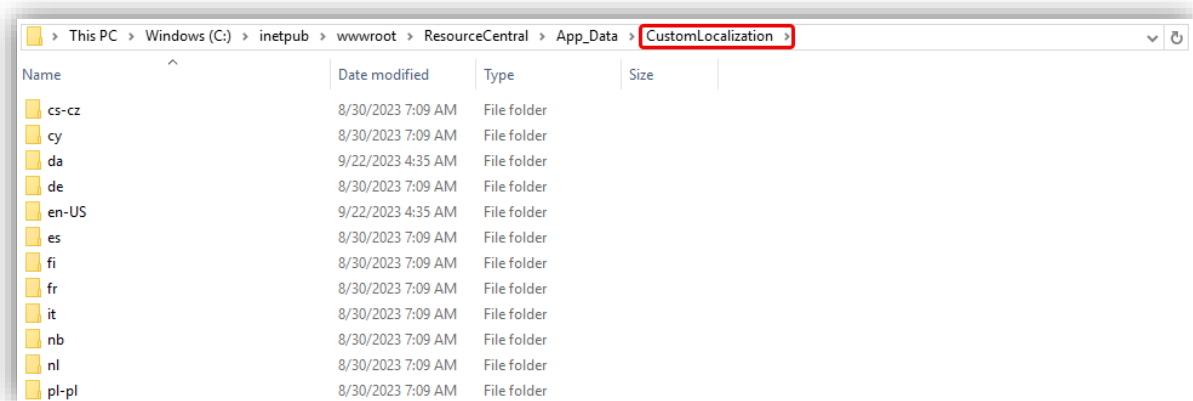

6. Open the PO file (root.po) in the folder of the same language you selected in **CustomLocalization** folder.
7. Paste the text block into this PO file and make change to the translation as you wish.

```
*root - Notepad
File Edit Format View Help
#. "http://pic.add-on-development.com/PropertiesDialog_warn_when_confirm_del_floor_plan_image.png"
msgctxt "Tree"
msgid "This image is being used for floorplan. Are you sure you want to delete it?"
msgstr "このイメージは、現在フロアプランで使用されています。削除してもよろしいですか?"
```

8. Save the file to finish.

Custom localization for Email template

1. Go to **Localization** folder and find the right language folder.
(By default, it is located at: *C:\inetpub\wwwroot\ResourceCentralNotificationService\Resources\Localization*)

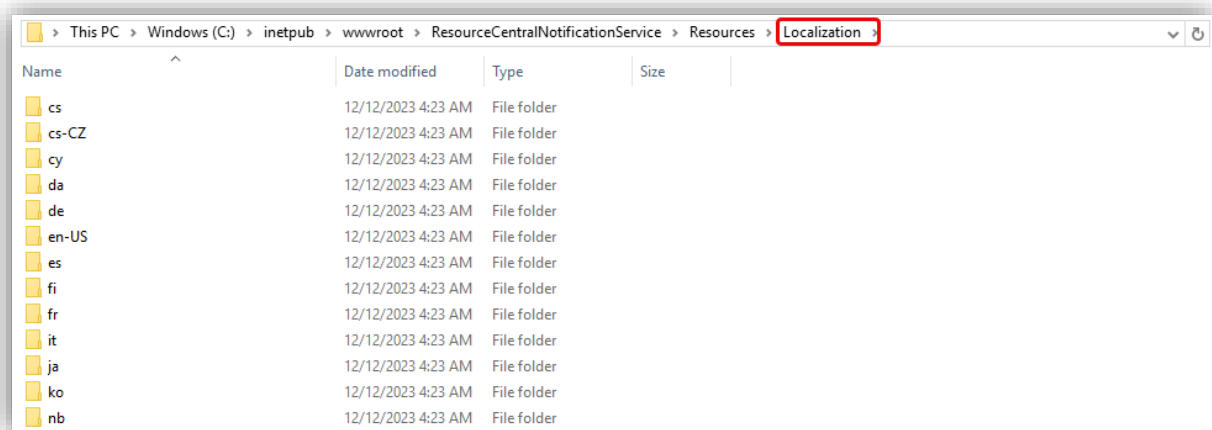

2. Open the specific language folder that you want to make change.
3. Open the PO file (root.po) in that folder.
4. Search for the text that you want to modify and copy the whole block of the text.

```
ja - Notepad
File Edit Format View Help

msgid "The following visitors have arrived"
msgstr "次の訪問者が到着しました"

msgid "The meeting has been cancelled after the deadline for Catering."
msgstr "この会議はケータリング期限後にキャンセルされました。"

msgid "The meeting has been cancelled after the deadline for Services."
msgstr "この会議はサービス期限後にキャンセルされました。"

msgid "The meeting has been cancelled after the deadline."
msgstr "この会議は期限後にキャンセルされました。"
```

5. Go to **CustomLocalization** folder and find the right language folder (By default, it is located at: *C:\inetpub\wwwroot\ResourceCentralNotificationService\Resources\CustomLocalization*)
6. Open the PO file (root.po) in the folder of the same language you selected in **CustomLocalization** folder.
7. Paste the text block into this PO file and make change to the translation as you wish.

```
*root - Notepad
File Edit Format View Help
msgid "The meeting has been cancelled after the deadline."
msgstr "この会議は期限後にキャンセルされました。"

msgid "The organizer does not seem to have access to this resource, or the resource was busy."
msgstr "開催者がこのリソースにアクセスできないか、このリソースがビジーでした。"

msgid "The organizer has been notified, that the resource has been removed from the meeting."
msgstr "開催者は、このリソースが会議から削除されたことを通知されました。"

msgid "The resource"
msgstr "リソース"
```

8. Save the file to finish.

Custom localization for COM Add-in

Follow these steps to change a text for RC COM Add-in:

1. Go to the Add-in folder. By default, it is located at:
 - **All users:** (C:\ProgramData\Add-On Products\Resource Central\Add-in)
 - **Per user:** (C:\Users\sh.MS-ADD-ON\AppData\Local\Add-On Products\Resource Central\Add-in)
2. Open the Texts.json file (with Notepad or any other Text Editor)
3. Search for the text that you want to modify and make the changes to its translation as you wish
4. Save the file to finish.

NOTE: To ensure the COM Add-in automatically download the new versions of translation, you need to increase the value of the parameter "**Addin.UITextUpdate**". Refer to **RC Parameter Guide** for more details.

Resource Booking Policies and Permissions

If you want ResourceFinder to display which resources organizers are allowed to book, Resource Central can be setup to integrate with Exchange Resource policies and permissions to govern resource booking rules. ResourceFinder will then display the different policies and permissions, so organizers can see, if they can book resources. Or if e.g., a booking needs approval by a delegate due to breach of a policy.

The involved policies include:

- **AllowConflicts**
- **AllowRecurringMeetings**
- **MaximumConflictInstances**
- **ConflictPercentageAllowed**
- **More policies will be added in later release of Resource Central**

The involved permissions include:

9. **AllBookInPolicy**
10. **BookInPolicy**
11. **AllRequestInPolicy**
12. **RequestInPolicy**
13. **AllRequestOutOfPolicy**
14. **RequestOutOfPolicy**

You can see these permissions in resource's details → **Exchange Properties**, which are synchronized from Exchange Server. The Exchange properties cannot be modified from Resource Central.

For the feature to work on the ResourceFinder COM Add-in, the minimum requirement is version 4.00.0.146 and for RealTime Service it is required that the service account has the Exchange role "View-Only Organization Management", when you use groups on permissions and policies on Exchange Resources.

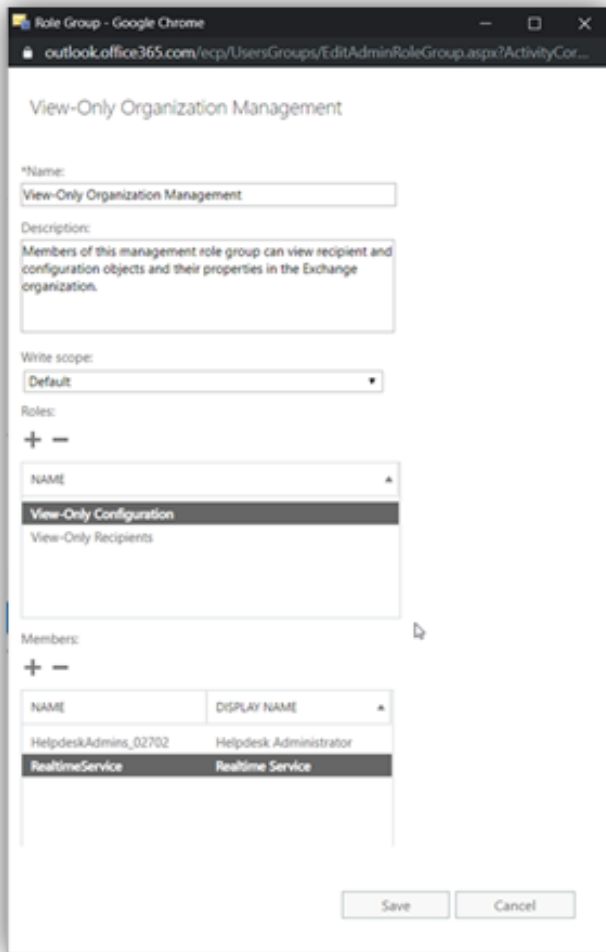

Resource Central uses the following Exchange properties to handle permissions and policies. For more detailed descriptions please go to Microsoft's webpage and read about Exchange CalendarProcessing.

The operation of Permissions service is influenced by 2 parameters:

Parameter	Description
ResourceFinder.DisablePermission	<p>This parameter controls the operation of Permissions feature. If value of this parameter is '1', the Permissions feature is turned off, policies and permissions in RC now will NOT follow the Permissions Flow. If this parameter is not created or created with any value other than '1', policies and permissions follow the Permissions Flow.</p> <ul style="list-style-type: none"> - For more information on how ResourceFinder uses Exchange Policies and Permissions, please refer to RC Administrator Guide - Resource Booking Policies and Permissions. <p>Default value of this parameter is '1'.</p>
ResourceFinder.HidelfNoPermission	<p>This parameter controls the availability of declined resources following InPolicy permissions. If value of this parameter is '1', the declined resources (following InPolicy permissions) are hidden. If this parameter is not created or created with any value other than '1', the declined resources (following InPolicy permissions) are still visible.</p>

The Permission/policy settings in Exchange and their effect on the organizers' booking of resources have been illustrated below:

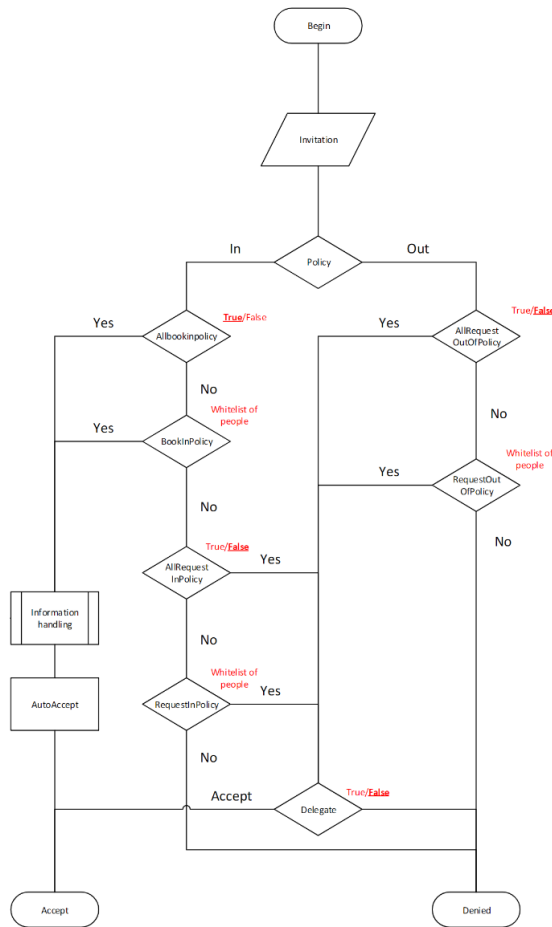

The permissions and policies feature can be found in ResourceFinder (COM and Outlook Add-in) and Mini ResourceFinder in Booking Manager. The following figure is an example with the possible icons showing permissions for the booking:

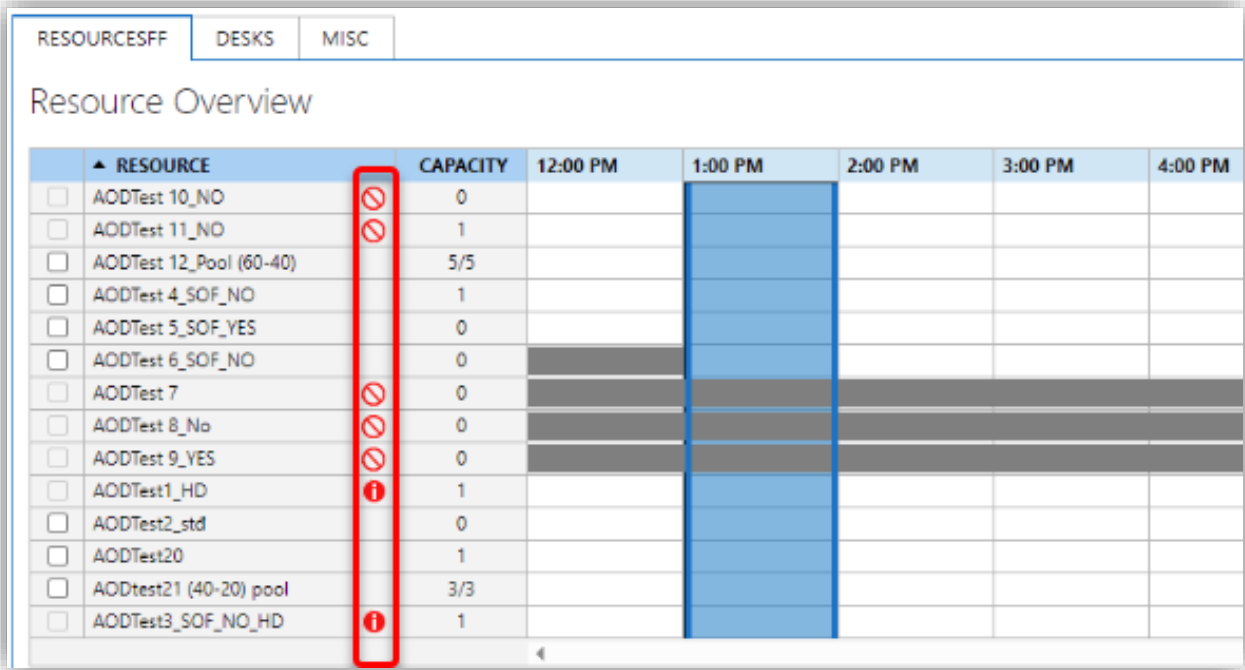

Icon	Descriptions
	You cannot book this resource because your meeting request conflicts with the resource's booking policies.
	You do not have permission to book this resource. If this icon shows up next to a virtual resource, it can also warn that the child resources are not similarly configured in Exchange, leading to the booking being blocked.
	Booking this resource requires approval by the resource's delegate. Your request will be forwarded, pending approval.
	You can book this resource for the meeting but be aware of the conflicted occurrences.

OrganizerGroups synchronization

To make permission work, ResourceFinder needs to know the organizer's Groups to compare them with the groups associated with resources permission policies in Exchange. As a result, ResourceFinder can determine which resources can be booked by the organizer.

These groups are also used for Location Percentage (please refer to [Locations](#)).

To disable this feature, you can either:

- Set the parameter **RC.OrganizerGroups.Enable** value to 0 (by default its value is 1).
- Disable permission and don't use Location Percentage feature.

The synchronization of the organizers' groups will need to happen continuously to implement new users and any changes to the groups done in Active Directory. This synchronization is triggered in two ways:

Using ResourceFinder/Outlook Add-in

ResourceFinder/Outlook Add-in only loads groups for:

1. New organizers
2. Inactive organizers who have not used ResourceFinder in the last X days.
 - a. X days is compared to the 'LastPoll' date in OrganizerPreference table and the current date ('X' is determined by the parameter **RC.OrganizerPreferences.LastPoll.Days**, by default it is 30 days)

NOTE: 'LastPoll' date is the most recent date when you use ResourceFinder/Outlook Add-in.

In case (1), new users open ResourceFinder the first time will see resources without permissions due to asynchronous loading process of groups. This is in order to not stall the load of ResourceFinder at the first load. They can reopen ResourceFinder and it will show the permissions once the loading process is completed. From there on, ResourceFinder will always show permissions.

In case (2), inactive organizers' data is removed from the following tables **OrganizerGroups**, **OrganizerLocation**, **OrganizerResourceViewable**. Thus, their case becomes similar to case (1).

Organizers who do not belong to either case are not synchronized when opening ResourceFinder. If their permissions change, the changes will take effect, but ResourceFinder/Outlook Add-in still shows old permissions until the Maintenance service update the changes during a scheduled run.

Setting synchronization for RC Maintenance service

OrganizerGroups for active organizers are synchronized by Maintenance service, which can be set by two following parameters:

- **RC.OrganizerGroups.IntervalDays:** determines the synchronization frequency (in days). By default, synchronization is done every five days.
- **RC.OrganizerGroups.Permission.StartTime:** determines the time of day to start synchronization. By default, synchronization starts at 02:00 AM.

This means by default, OrganizerGroups synchronization starts every 5 days at 02:00 AM.

Synchronization only applies for organizers with:

- 'LastPoll' date being at least 'X' days older than the current date ('X' is determined by the parameter **RC.OrganizerPreferences.LastPoll.Days**)
- 'LastUpdated' date being at least 'N' days older than the current date ('N' is determined by the parameter **RC.OrganizerGroups.IntervalDays**)

NOTE: 'LastUpdated' date in OrganizerGroups table is the most recent date when synchronization occurred. It is updated after successful synchronization.

For more details on the mentioned parameters, please refer to **RC Parameter Guide**.

Ensuring load performance in ResourceFinder

In order to ensure load performance on ResourceFinder when using Exchange permissions and policies, Resource Central has included a feature to optimize this calculation¹.

- For new installations this will be by default configured at installation.
- For upgrades a migration of data needs to take place populating data into a new table.
 1. Please run the migration tool. For more information, please see **Migration Tool Guide**.
 2. After that enable the parameter **Reservations.ImproveCalendar.Enable**.

¹ Available from Resource Central 4.1 Service Release 3

Outlook on the web Support

Resource Central now enables you to use the add-in via Outlook on the web. This facility will only be available if you are using MS Exchange Online.

With ResourceFinder on Outlook on the web, you can perform almost all operations, as you can do with the Outlook Add-in desktop version. Some of the limitations in functionality are as follows:

1. When opening recurring appointment in Outlook on the web originally booked in Outlook desktop client, time of the series is lost, and the series becomes 'No-end date' appointment.

NOTE: There might be some difference in booking date time between Outlook Add-in and Outlook on the web Add-in:

- Time zone of Outlook Add-in: based on time zone in client machine
- Time zone of Outlook on the web Add-in:
 - ResourceFinder: based on user's time zone on O365
 - MyMeetings:
 - Basic parameter Use Default Time Zone = Yes → use RC system time zone
 - Basic parameter Use Default Time Zone = No → use O365 time zone

Dependency function

Overview

This function helps you set up the dependency between properties and lookup tables. With this feature, you can establish the form to show different tables when a property is booked (dependent on value of the property), or to make a property required when something is booked in the order form or make a property (child property) show up when another property (parent property) is selected in the order form.

The dependency function is controlled by the parameter **LookupValuesAndProperties.Dependency.Enable**. After being enabled, the changes will be available in the following areas:

1. Property details:

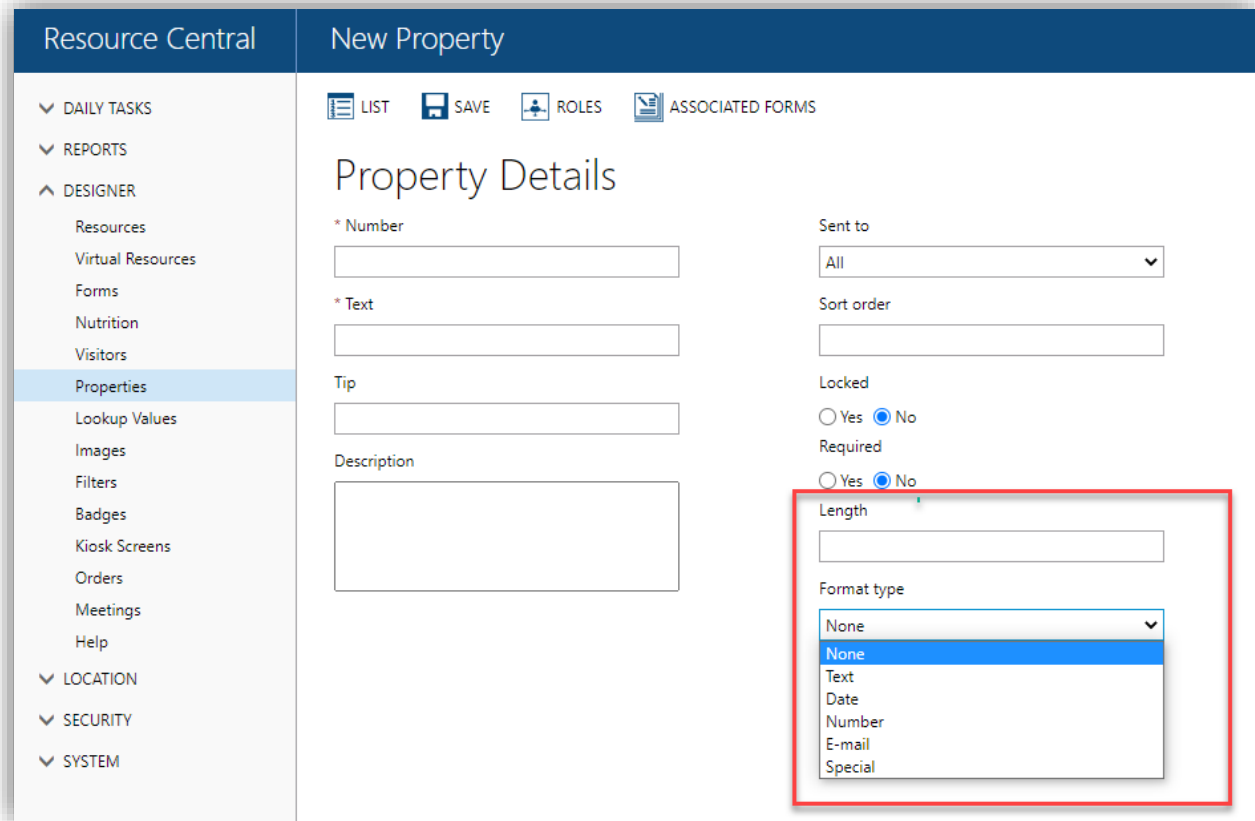

Figure 422. Property details

Field	Descriptions
Length	Maximum number of characters that can be entered as value of this property
Format type	<p>Select format for value of this property.</p> <p>None: Value with all format types is accepted.</p> <p>Text: Entered value must be text (e.g., 'car', 'bike')</p> <p>Date: Entered value must be date format (e.g., 15/04/2020)</p> <p>Number: Entered value must be digits (e.g., 25464)</p> <p>E-mail: Entered value must be email address (e.g., johndoe@hotmail.com)</p> <p>Special: Entered value must be a sequence of characters that forms a search pattern following Regular expression definition (e.g., x{5}-g{6})</p>

2. Lookup table details

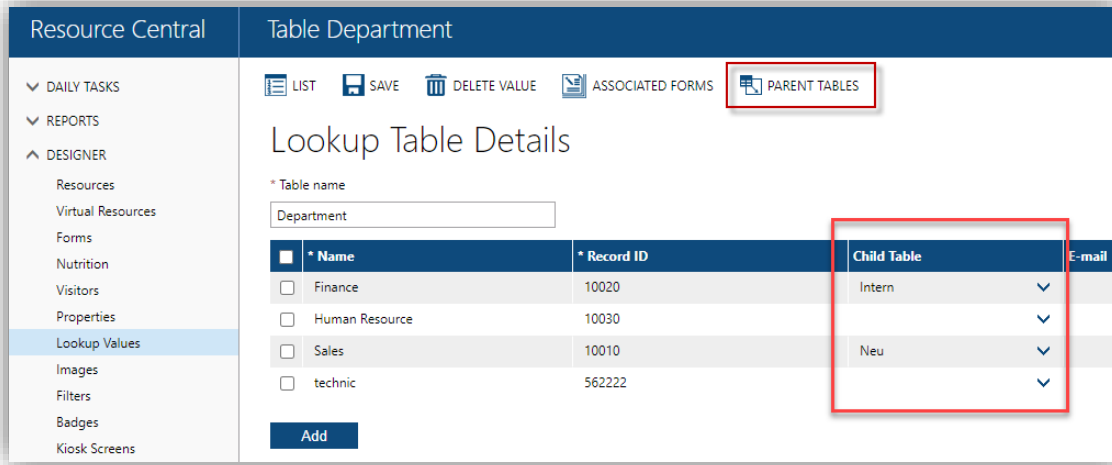

Figure 423. Lookup table details

A lookup table can be **Child Table** to another lookup table, and in turn, can be **Parent Table** to another one. This multiple level of dependency can be unlimited as long as it's not a loop, i.e., a lookup table cannot be both Child and Parent to another one.

3. Form Design when inserting properties

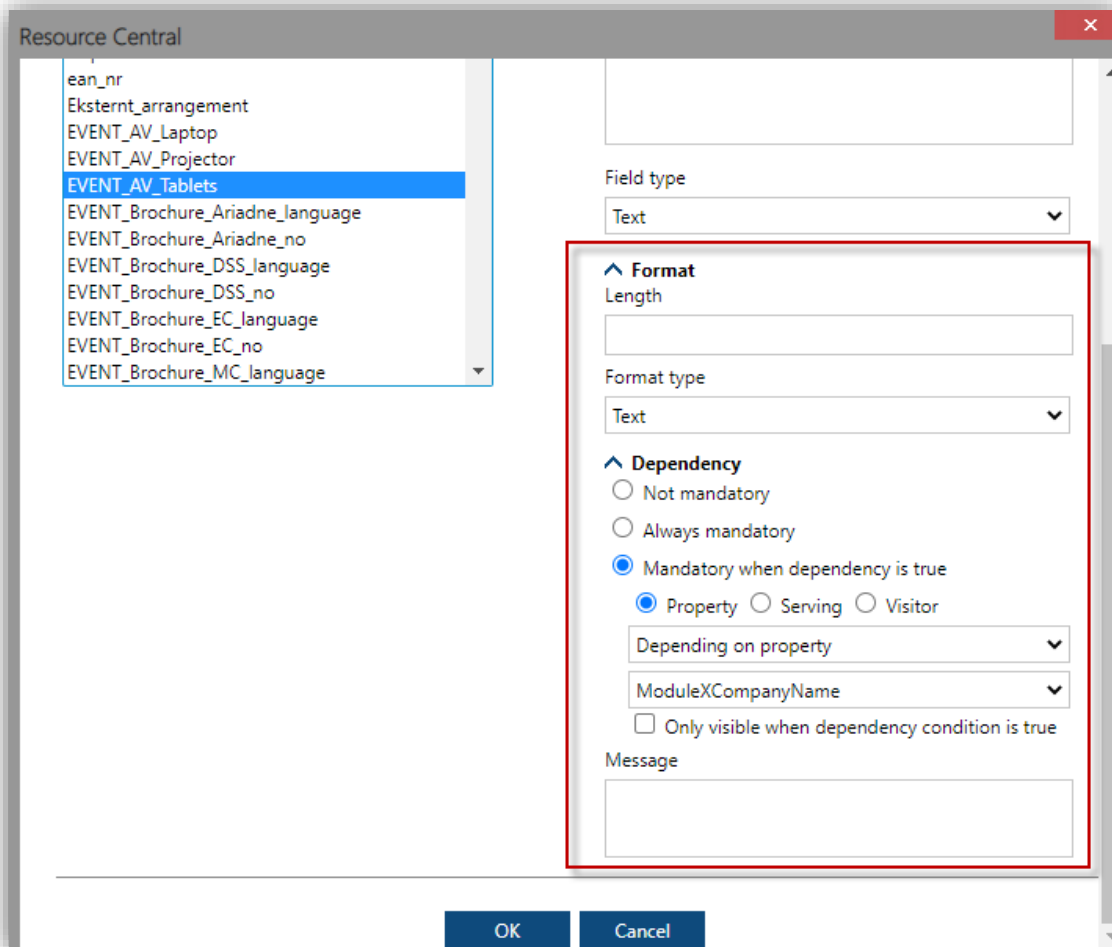

Figure 424. Insert a property to a form

Select dependency conditions relative to property, serving or visitor.

Option		Descriptions
Property	Depending on property	This property will be required when another property is booked. This parent property can be selected in the drop-down list underneath.
	Depending on specific property value	This property will be required when another property is booked with a specific value. This parent property can be selected in the drop-down list underneath and the value can be: <ul style="list-style-type: none"> - input in the textbox (if the field type of the principal property is text or text area), or - selected from the drop-down list (if the field type of the principal property is radio button, lookup button or drop-down list).
	Use dependent child table	This property will be required when another property is booked. This parent property can be selected in the drop-down list underneath. With this selection, Organizer can see all values of all child tables.
Serving	Number of deliveries	This property will be required when the number of deliveries in the order reaches the established number.
	Total amount	This property will be required when the total amount in the order reaches the established number (e.g., making a cost info property mandatory when the total cost is more than 0).
Visitor		This property will be required when organizer registers a visitor in the order form.
Only visible when dependency is true		Check on this if you want this property to be initially hidden in the order form and only available when a dependency condition is met.

After making necessary setup in each property, creating necessary tables, inserting properties into the form, assigning form to a resource, the dependency can be seen when organizer books that resource and opens the Order Form.

Typical use of the feature

The use of the dependency feature can be illustrated by the following examples:

Make a property visible or hidden depending on another property

Let's assume that you want to set up so that when Organizer selects a value for property **Vehicle**, the property **Vehicle brand** will show up with a table depending on the value selected for the property **Vehicle**.

To do this, you need to make the setups in:

15. Create child tables of vehicle brands:

In this example, 2 tables **Car** and **Bike** are created, each with 3 values:

Lookup Table Details

* Table name
Bike

<input type="checkbox"/>	* Name	* Record ID	Child Table
<input type="checkbox"/>	Honda	Bike_001	▼
<input type="checkbox"/>	Piaggio	Bike_003	▼
<input type="checkbox"/>	Yamaha	Bike_002	▼

Lookup Table Details

* Table name
Car

<input type="checkbox"/>	* Name	* Record ID	Child Table
<input type="checkbox"/>	Mazda	Car_003	▼
<input type="checkbox"/>	Mercedes	Car_001	▼
<input type="checkbox"/>	Toyota	Car_002	▼

16. Create parent table **Vehicles** and select child tables for it:

Lookup Table Details

* Table name
Vehicles

<input type="checkbox"/>	* Name	* Record ID	Child Table
<input type="checkbox"/>	Bike	vehicle_002	Bike ▼
<input type="checkbox"/>	Car	vehicle_001	Car ▼

17. Create 2 Properties: **Vehicle** (parent property) and **Vehicle brand** (child property).

18. Create a form and insert the parent property **Vehicle**, select **Drop Down List** for Field type, select **Vehicles** for Table name.

Properties

Select a property to insert into the form. You can select between a number of different field types.

Properties

- RC_CostCode
- RC_LapTop
- RC_LapTop_assistance
- RC_NumberOfPersons
- RC_Organizer_Company
- RC_OrganizerName
- RC_Projector
- RC_TablePlan
- RC_Whiteboard
- RC_Wifi_Access
- RC_Wifi_Access_QTY
- RemoveWall
- report.NrOfAttendees
- required1
- Tesssst
- VB_Ticket_Dinner
- VB_Tickets_Comment
- VB_Tickets_qty
- Vehicle**
- Vehicle_brand

Include caption

Vehicle

Group

GroupName='PROP_239_Vehicle_Group'

Tool tip

Field type

Drop Down List

Table name

Vehicles

Dependency

Not mandatory

Always mandatory

Mandatory when dependency is true

19. Insert child property **Vehicle brand**, select **Drop Down List** for **Field type**, select Car or Bike for Table name and make the setup as shown in the following figure.

RC_NumberOfPersons

RC_Organizer_Company

RC_OrganizerName

RC_Projector

RC_TablePlan

RC_Whiteboard

RC_Wifi_Access

RC_Wifi_Access_QTY

RemoveWall

report.NrOfAttendees

required1

Tesssst

VB_Ticket_Dinner

VB_Tickets_Comment

VB_Tickets_qty

Vehicle

Vehicle_brand

GroupName='PROP_243_Vehicle_brand_Group'

Tool tip

Field type

Drop Down List

Table name

Car

Dependency

Not mandatory

Always mandatory

Mandatory when dependency is true

Property Serving Visitor

Use dependent child table

Vehicle

Only visible when dependency condition is true

Message

NOTE: For Table name field, you need to select a table being the child table of the one associated with the parent property.

In this example, the parent property (Vehicle) is associated with **Vehicles** table which has 2 child tables: **Car** and **Bike**. Therefore, the table you need to select for **Table name** field when inserting property **Vehicle brand** is either **Bike** or **Car**.

Remember to check on option **Only visible when dependency is true** if you want to hide this property initially.

Finally, save the form, assign the form to a resource, and the feature is ready to be used by the Organizer.

After this, when organizer opens Order Form, only property Vehicle shows up.

When organizer selects **Bike** for property **Vehicle**, the property **Vehicle brand** shows up. Open the drop-down list for Vehicle brand, the data table is displayed as shown in the figure below:

When organizer selects **Car** for property **Vehicle**, the property **Vehicle brand** shows up. Open the drop-down list for Vehicle brand, the data table is displayed as shown in the figure below:

Make use of Group section when making elements in the form visible or hidden depending on a property

Using the approach in the previous section, you can make a property visible or hidden based on another property. What if you want to make other elements (such as texts, image, etc.) to show up or disappear depending on a property? Making use of Group section can help you do that.

Context: Property **Vehicle** only shows up when organizer books an item for catering. If property **Vehicle** shows up, the property **Vehicle brand** AND the text '*Extra services have been booked*' will be accordingly visible.

Here's how you do it:

20. Create a form, insert Property **Vehicle** and make the dependency setup as shown in the following figure for this property:

The screenshot shows the configuration interface for the 'Vehicle' property. On the left is a list of properties, with 'Vehicle' selected. On the right, the configuration options are as follows:

- Group:** A red box highlights the 'Group' field with the value 'GroupName='PROP_239_Vehicle_Group''.
- Field type:** Set to 'Drop Down List'.
- Table name:** Set to 'Vehicles'.
- Dependency:**
 - Not mandatory
 - Always mandatory
 - Mandatory when dependency is true
- Dependency Condition:** A red box highlights this section, which includes:
 - Radio buttons for Property, Serving, and Visitor.
 - A dropdown menu set to 'Number of deliveries', a 'More' dropdown, and a numeric field set to '0'.
 - Only visible when dependency condition is true
- Message:** The text 'Book catering' is entered in the message field.

NOTE: Remember to copy the value in **Group** field for later use.

2. Insert property **Vehicle brand**, you don't need to set up anything special for this property.
3. Write the text '*Extra services have been booked*' in the order form:

The screenshot shows the order form interface. At the top is a rich text editor toolbar with various icons. Below the toolbar, the form contains:

- A dropdown menu labeled 'Vehicle' with a downward arrow.
- A text input field labeled 'Vehicle brand'.
- The text '*Extra services have been booked.*' displayed below the input field.

4. Click [**Source**] button, you can see all current elements in the order form:

```
<div><span groupname="PROP_239_Vehicle_Group" propertyid="PROP_239_Vehicle">Vehicle</span>&nbsp;&nbsp;&nbsp;<select depend
<div><span groupname="PROP_243_Vehicle_brand_Group" propertyid="PROP_243_Vehicle_brand">Vehicle brand</span>&nbsp;&nbsp;&lt;i
<div><i>Extra services have been booked.</i></div>
```

As highlighted in the above figure, you can see the **groupname** of the property **Vehicle**. This value has been mentioned in **Step 1**.

5. Paste the groupname of property Vehicle to <div> tags of other elements (including the property Vehicle brand and the text 'Extra services have been booked') as shown in the figure below:

```
<div><span groupname="PROP_239_Vehicle_Group" propertyid="PROP_239_Vehicle">Vehicle</span>&nbsp;&nbsp;&nbsp;<select depend
<div Groupname='PROP_239_Vehicle_Group'><span groupname="PROP_243_Vehicle_brand_Group" propertyid="PROP_243_Vehicle_b
<div Groupname='PROP_239_Vehicle_Group'><i>Extra services have been booked.</i></div>
```

6. Save the form, assign this form to a resource.

After this, when organizers book no delivery, property **Vehicle is hidden**.

ESPOO - KOKOUSHUONE 1 Order

If you require extra services for your resource booking, please enter the number of deliveries, and fill out this form.

Number of deliveries: No Delivery

Visitors

Register visitors

Extra services for your meeting

If organizer books an item, the property **Vehicle** and other elements attached to it will show up:

ESPOO - KOKOUSHUONE 1 Order

If you require extra services for your resource booking, please enter the number of deliveries, and fill out this form.

Number of deliveries:

1st service: Delivery time at resource's local time

Comments:

Serving 1

Name	Price	Qty
<input type="checkbox"/> Chi-Drink	3.00	Min. Qty: 5
Chi-vesi	1.50	<input type="text"/>
kahvi	2.00	<input type="text"/>
suklaa	0.50	<input type="text"/>
Tee	1.50	<input type="text"/>
Catering Total		<input type="text" value="0.00"/>

Visitors

Register visitors

Extra services for your meeting

Vehicle

Vehicle brand

Extra services have been booked

Tax receipt feature

Overview

The demand for a tax receipt for the tax authorities has been rising and this feature was created to address that demand. The tax receipt, in this scenario, must be used when the company has an external caterer. In that case the internal and external attendees must be listed.

Tax receipt feature is controlled by the parameter **TaxReceipt.Enable**. For more details about this parameter, please refer to **RC Parameter Guide**.

Where to set up additional details for tax receipt

When this feature is turned on, you can find that in RC backend the section “Tax Receipt” is available under **Designer** in which you can make all configurations for this feature. Refer to this [section](#) for more details.

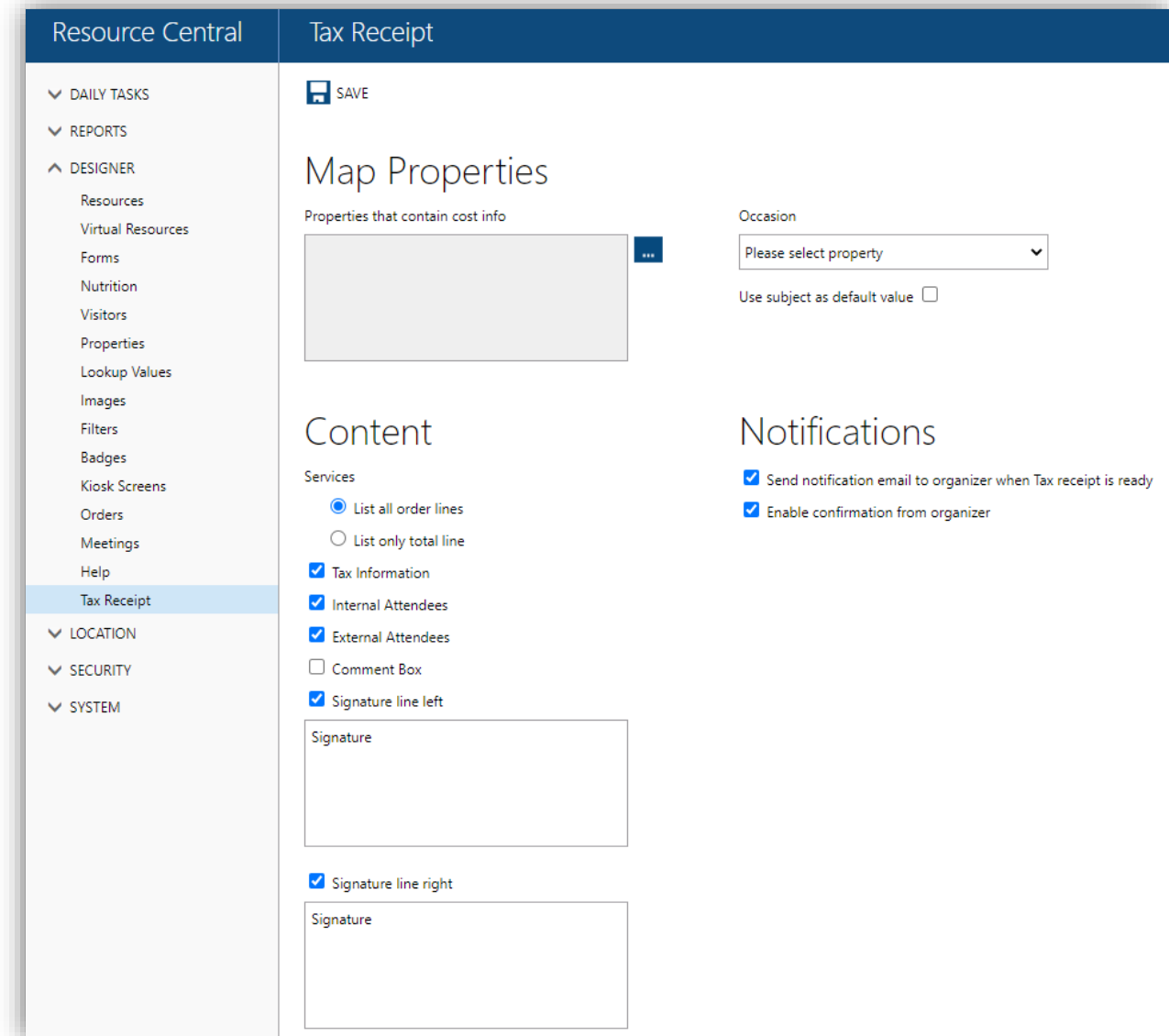

Figure 425. Designer/Tax Receipt

You also need to make configurations in each Location. When the feature is turned on, some new fields are available in a location property:

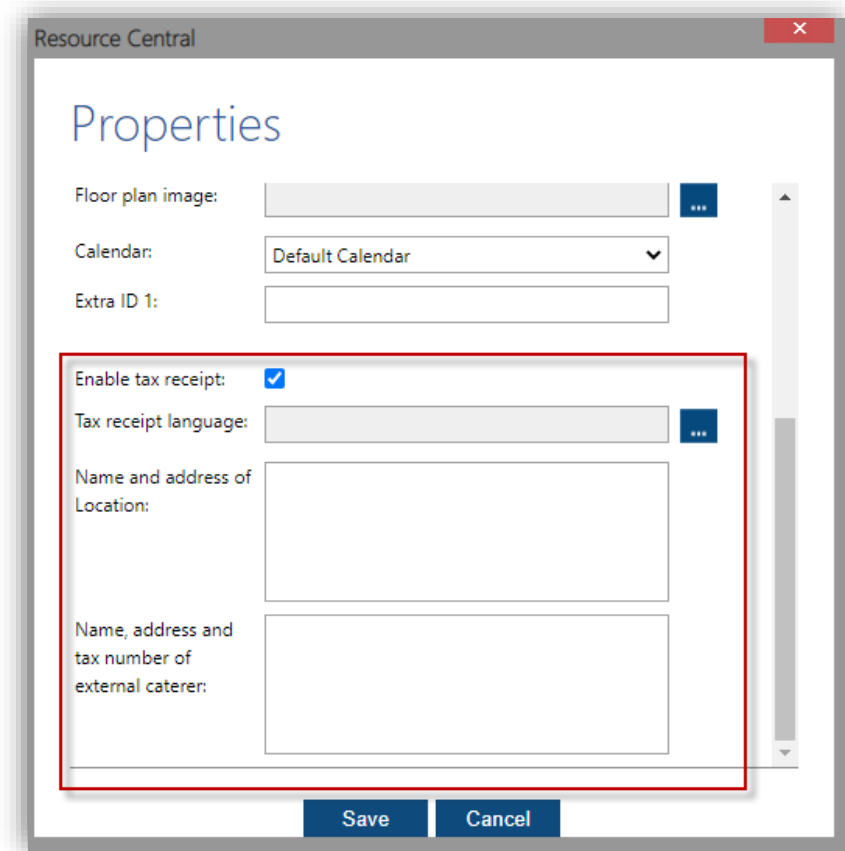

Figure 426. Location properties

Field	
Enable Tax Receipt	This will enable the use of Tax Receipt at this location. When disabled, the below fields will be deactivated
Tax receipt language	This will control the language when the pdf with the tax receipt is created.
Name and address of location	Fill in name and address of the location.
Name, address and tax number of external caterer	Fill in name, address, and tax number of the external caterer.

You also need to set up the VAT % on item's details or menu's details.

The screenshot shows the 'Item Details' form with the following fields and values:

- * ID: 13
- Name: Item3
- * Location: Locations
- * Group name: Item
- Sales price including VAT: 20
- Cost price: 0
- VAT %: 10 (highlighted with a red box)
- Extra Id 1: (empty)

Figure 427. Item's details

After setting up all these, the tax receipt feature is ready to work.

Flow of a tax receipt

	Order status	Tax receipt status
SP clicks [Send Tax Receipt]	Arranged	Sent
Organizer clicks [Decline] in email or My Meetings	Arranged	Declined
Organizer clicks [Accept] in email or My Meetings	Locked	Confirmed

Red arrows on the left side of the table indicate a flow from the 'Declined' row to the 'Accepted' row, and from the 'Accepted' row back to the 'Send Tax Receipt' row.

The above diagram can be described as in the following process:
When the service provider (SP) finishes reviewing the order, click [**Send Tax Receipt**], an email will be sent to organizer.

1. If the confirmation flow is enabled in the configuration screen (**Designer/Tax Receipt**), organizer receives an email as shown in the following figure:

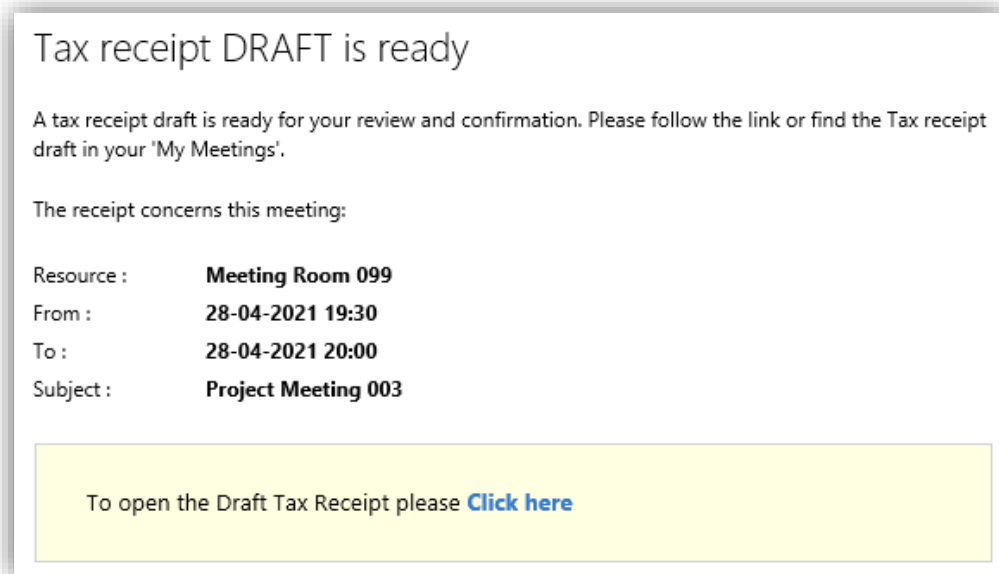

In this case, organizer can click on the link (Click here) to open the tax receipt (which can be done in My Meetings as well), then he can accept or decline the receipt.

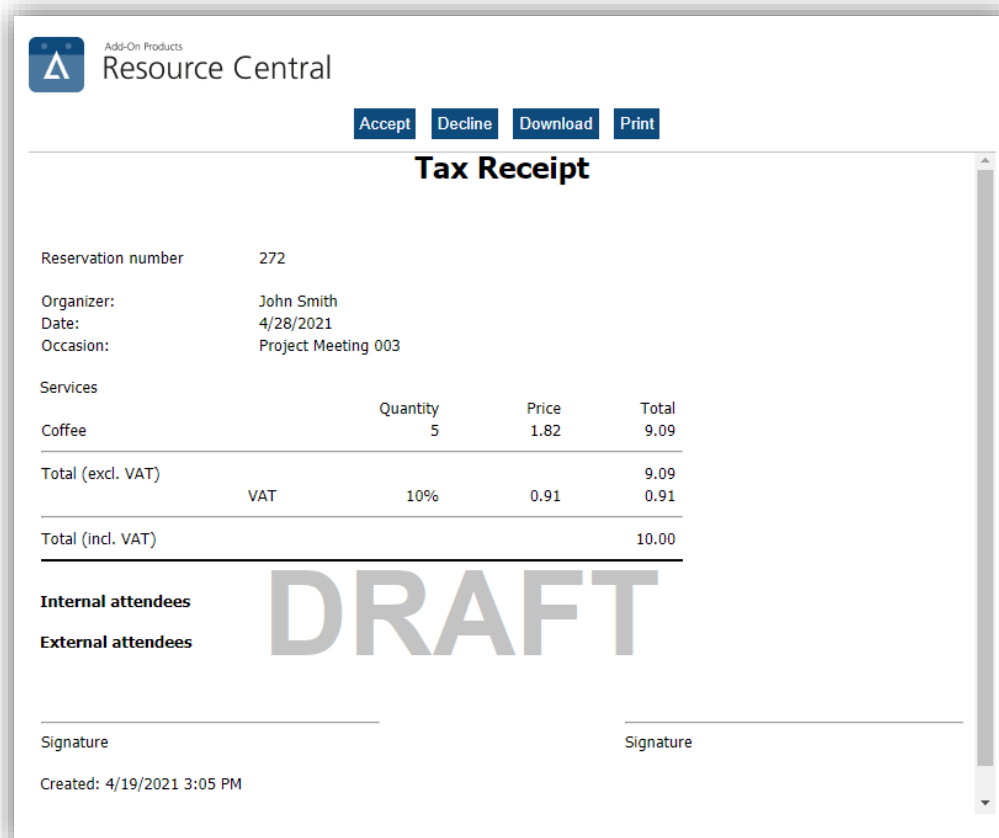

- a. If organizer declines the Tax Receipt, order status is changed to **Arranged** and tax receipt status is changed to **Declined**.
- b. If organizer accepts the Tax Receipt, order status is changed to **Locked** and tax receipt status is changed to **Confirmed**.

2. If the confirmation flow is NOT enabled in the configuration screen, the order status will go directly to **Locked** when the tax receipt is sent, and organizer receives an email as shown in the following figure:

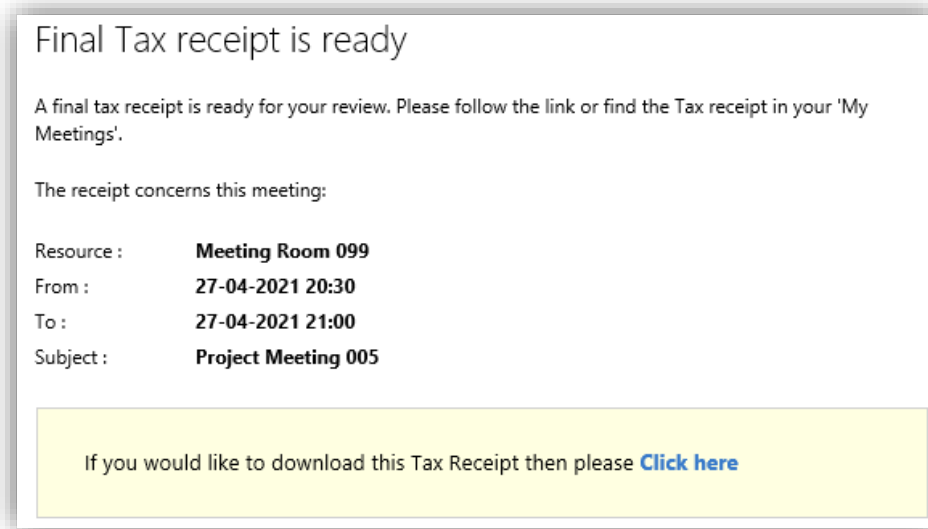

Pooled Resources - Configuration in Exchange

For Pooled Resources to work, the following configurations for the resources need to be established for each of the resources on the Exchange server:

- Resourcetype = Resource
- EnforceCapacity = No
- AllowConflict = Yes
- Conflict Percentage Allowed = 100
- Maximum Conflict Instances = 1000

NOTE: Pooled Resource do not support using a delegate setup. The feature will work with “All Book in Policy” set to both Yes and No.

For these resources acceptance and decline will be handled by Resource Central, based on the capacity of the resource and the internal and external utilization percentages on the location level.

In Outlook on the web, the organizer will be informed that the resource is not available and will be presented with a warning. To avoid this, it is recommended to set access right setting to “None” for the resources of this RC resource type. This will make the availability show as unknown/(?) and the warning will not be shown.

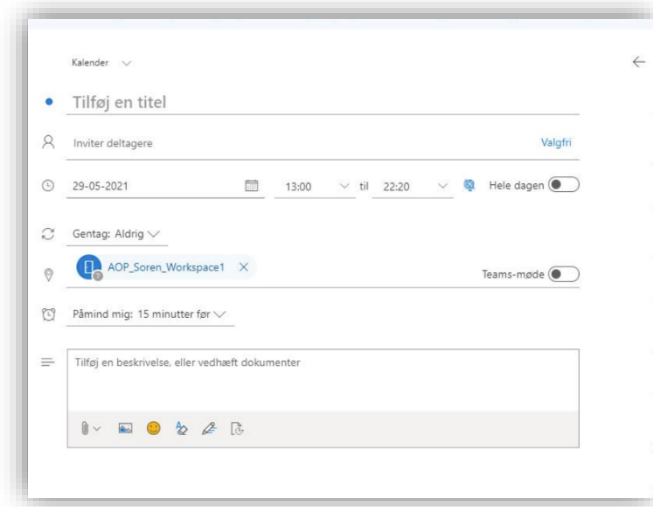

PS command example

```
Set-MailboxFolderPermission Error! Hyperlink reference not valid. -User Default -
AccessRights None
```

Set up external percentage using Resource Data Synch

The calculation of the external utilization is based on where the organizer and the resource are located. This is controlled through the Active Directory (AD) where AD groups are mapped on users and resources.

NOTE: Permission feature in RC must be turned on (parameter **Permission.Disable** = 0)

In order to set up the mapping, follow these steps under the form of an example:

1. Add organizer JohnSmith to these groups in Exchange: AOPTEAM2@aoprc.onmicrosoft.com; everyone@aoprc.onmicrosoft.com
2. Add pooled resource **pooled_res1** to group AOPTEAM2@aoprc.onmicrosoft.com in Exchange by running the following command:

```
Set-Mailbox -Identity pooled_res1 -CustomAttribute15
'AOPTEAM2@aoprc.onmicrosoft.com'
```

CustomAttribute15 is just used as an example.

3. Open **RealTime Service Manager** → **Resource Central** → **Resource Data Synch** → **Mailbox properties**. Select and Add **MsExchCustomAttribute15**

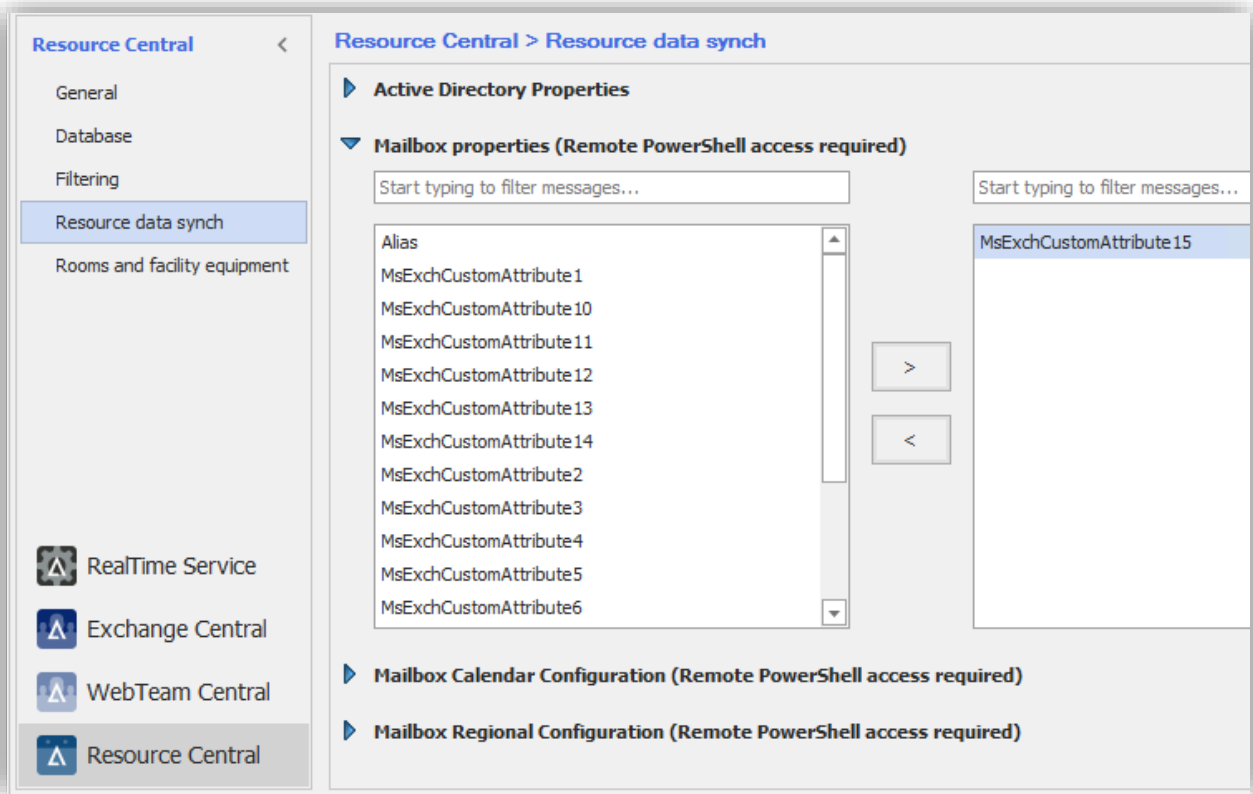

4. Open **RC backend** → **Resource Data Synch**, select Field in Resource Central = **Location Identifier** and select Type of synchronization setting = **MsExchCustomAttribute15**.

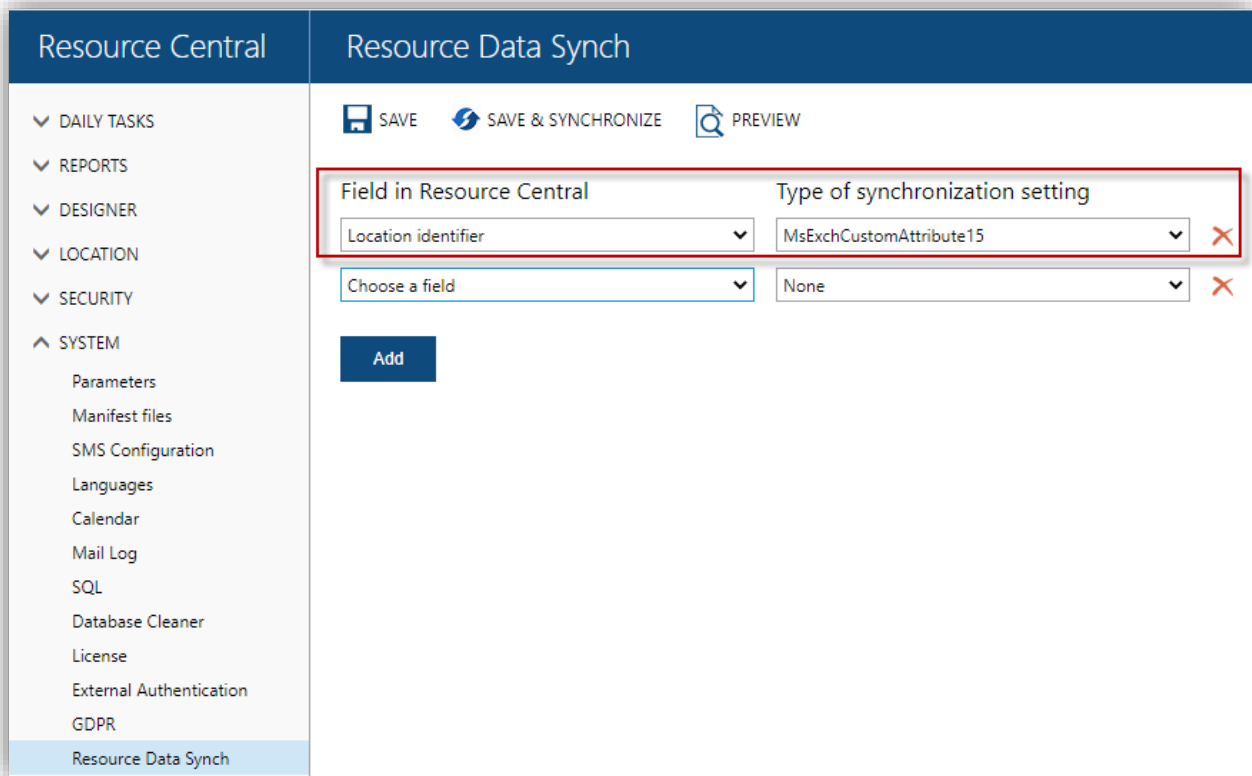

Click [**SAVE & SYNCHRONIZE**] button to finish.

External Users

If your organizers can book on your own platform, these organizers will be considered **external users** (or **external organizers**) by Resource Central as they do not make reservation from RC itself.

In this case, specific configuration is required in order to send data of external organizers from the external platform to RC database, and in return, RC system can send order form to those external organizers.

For more details on how to configure External users feature and how it functions, please refer to the **External Users Configuration Guide**.